

Operator's manual

## Gasoline demolition hammer

# BH

## 23, 24, 65



02.2011

0226390en / 004



### **Manufacturer**

Wacker Neuson SE

Preußenstraße 41

80809 München

[www.wackerneuson.com](http://www.wackerneuson.com)

Tel.: +49-(0)89-354 02-0

Fax: +49-(0)89-354 02-390

**Translation of the original operator's manual in German**



**WACKER  
NEUSON**

---

<b>1</b>	<b>Foreword</b> .....	<b>5</b>
<b>2</b>	<b>Introduction</b> .....	<b>6</b>
	2.1 Means of representation for this operator's manual .....	6
	2.2 Wacker Neuson representative .....	7
	2.3 Described machine types .....	7
	2.4 Identification of the machine .....	8
<b>3</b>	<b>Safety</b> .....	<b>9</b>
	3.1 Principle .....	9
	3.2 Qualification of the operating personnel .....	12
	3.3 Protective gear .....	13
	3.4 Transport .....	14
	3.5 Operating safety .....	15
	3.6 Safety during the operation of hand machines .....	17
	3.7 Safety during the operation of combustion engines .....	17
	3.8 Maintenance .....	19
	3.9 Safety devices .....	21
<b>4</b>	<b>Safety and information labels</b> .....	<b>22</b>
<b>5</b>	<b>Scope of delivery</b> .....	<b>24</b>
<b>6</b>	<b>Structure and function</b> .....	<b>25</b>
	6.1 Application .....	25
	6.2 Functional description .....	25
<b>7</b>	<b>Components and operator's controls</b> .....	<b>26</b>
<b>8</b>	<b>Transport</b> .....	<b>28</b>
<b>9</b>	<b>Initial start up</b> .....	<b>29</b>
<b>10</b>	<b>Use and operation</b> .....	<b>30</b>
	10.1 Prior to starting the machine .....	30
	10.2 Adjusting the machine .....	31
	10.3 Changing tools .....	32
	10.4 Starting up .....	33
	10.4.1 Starting the engine .....	34
	10.5 Operating the machine .....	37
	10.6 Decommissioning .....	38
<b>11</b>	<b>Maintenance</b> .....	<b>39</b>
	11.1 Maintaining the emission control system .....	39

---

11.2	Maintenance personnel qualifications .....	39
11.3	Maintenance schedule .....	40
11.4	Maintenance work .....	40
11.4.1	Cleaning machine .....	40
11.4.2	Topping up with fuel .....	41
11.4.3	Checking/cleaning air cleaner .....	43
11.4.4	Lubricating the machine .....	44
11.4.5	Checking/cleaning/replacing spark plug .....	45
11.4.6	Checking the tool holder for wear .....	46
<b>12</b>	<b>Malfunctions .....</b>	<b>47</b>
<b>13</b>	<b>Storage .....</b>	<b>48</b>
<b>14</b>	<b>Accessories .....</b>	<b>49</b>
14.1	Truck .....	49
<b>15</b>	<b>Technical data .....</b>	<b>51</b>
15.1	BH 23 .....	51
15.2	BH 24 .....	53
15.3	BH 65 .....	56
<b>16</b>	<b>Emission control systems information and warranty .....</b>	<b>58</b>
16.1	Emission control system background information .....	58
16.2	Limited defect warranty for Wacker Neuson emission control systems .....	59
<b>17</b>	<b>Glossary .....</b>	<b>63</b>
17.1	Use of oxygenated fuels .....	63
	<b>EC Declaration of Conformity .....</b>	<b>65</b>

## 1 Foreword

This operator's manual contains information and procedures for the safe operation and maintenance of your Wacker Neuson machine. In the interest of your own safety and to prevent accidents, you should carefully read through the safety information, familiarize yourself with it and observe it at all times.

This operator's manual is not a manual for extensive maintenance and repair work. Such work should be carried out by Wacker Neuson service or authorized specialists.

The safety of the operator was one of the most important aspects taken into consideration when this machine was designed. Nevertheless, improper use or incorrect maintenance can pose a risk. Please operate and maintain your Wacker Neuson machine in accordance with the instructions in this operator's manual. Your reward will be troublefree operation and a high degree of availability.

Defective machine parts must be replaced immediately!

Please contact your Wacker Neuson representative if you have any questions concerning operation or maintenance.

All rights reserved, especially reproduction and distribution rights.

Copyright 2011 Wacker Neuson SE

No part of this publication may be reproduced in any form or by any means, electronic or mechanical, including photocopying, without the expressed written permission of Wacker Neuson.

Any type of reproduction, distribution or storage on data media of any type and form not authorized by Wacker Neuson represents an infringement of copyright and will be prosecuted.

We expressly reserve the right to make technical modifications – even without special notice – which aim at further improving our machines or their safety standards.

## 2 Introduction

### 2.1 Means of representation for this operator's manual

#### Warning symbols

This operator's manual contains safety information of the categories: DANGER, WARNING, CAUTION, NOTICE.

They should be followed to prevent danger to life and limb of the operator or damage to equipment and exclude improper service.



#### **DANGER**

This warning notice indicates immediate hazards that result in serious injury or even death.

- ▶ Danger can be avoided by the following the actions mentioned.
- 



#### **WARNING**

This warning notice indicates possible hazards that can result in serious injury or even death.

- ▶ Danger can be avoided by the following the actions mentioned.
- 



#### **CAUTION**

This warning notice indicates possible hazards that can result in minor injury.

- ▶ Danger can be avoided by the following the actions mentioned.
- 

#### **NOTICE**

This warning notice indicates possible hazards that can result in material damage.

- ▶ Danger can be avoided by the following the actions mentioned.
- 

#### Notes

**Note:** Complementary information will be displayed here.

### Instructions

- ▶ This symbol indicates there is something for you to do.
- 1. Numbered instructions indicate that you have to carry out something in a defined sequence.
- This symbol is used for lists.

### 2.2 Wacker Neuson representative

Depending on your country, your Wacker Neuson representative is your Wacker Neuson service, your Wacker Neuson affiliate or your Wacker Neuson dealer.

You can find the addresses in the Internet at [www.wackerneuson.com](http://www.wackerneuson.com).

The address of the manufacturer is located at the beginning of this operator's manual.

### 2.3 Described machine types

This operator's manual is valid for different machine types from a product range. Therefore some figures can differ from the actual appearance of your machine. It is also possible that the descriptions include components which are not a part of your machine.

Details for the described machine types can be found in the chapter *Technical data*.

### 2.4 Identification of the machine

#### Nameplate data

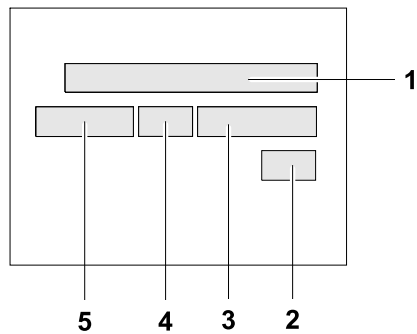

The nameplate lists information that uniquely identifies your machine. This information is needed to order spare parts and when requesting additional technical information.

- ▶ Enter the information of your machine into the following table:

Item	Designation	Your information
1	Group and type	
2	Construction year	
3	Machine no.	
4	Version no.	
5	Item no.	



## **3 Safety**

### **3.1 Principle**

#### **State of the art**

This machine has been constructed with state-of-the-art technology according to the recognized rules of safety. Nevertheless, when used improperly, dangers to the life and limb of the operator or to third persons or damage to the machine or other materials cannot be excluded.

#### **Proper use**

The machine must only be used for the following purposes:

- Breaking off concrete and asphalt and soil that is full of boulders.
- Breaking off concrete, masonry and other construction materials, untouched and frozen ground.
- Scarifying roads and concrete, asphalt, tar and wooden and stone paving.
- Cutting clay, loam, peat and salts.
- Breaking up compacted soils.
- Ramming in posts, probes and grounding rods.
- To tamp sleepers in track construction (only EH 22).

The machine may only be used with tools that are intended for use with the machine and the material being worked on.

The machine may not be used for the following purposes:

- Working on hazardous materials such as asbestos.

Its proper use also includes the observance of all instructions contained in this operator's manual as well as complying with the required service and maintenance instructions.

Any other use is regarded as improper. Any damage resulting from improper use will void the warranty and the liability on behalf of the manufacturer. The operator assumes full responsibility.

### Structural modifications

Never attempt to modify the machine without the written permission of the manufacturer. To do so will endanger your safety and the safety of other people! In addition, this will void the warranty and the liability on behalf of the manufacturer.

Especially the following are cases of structural modifications:

- Opening the machine and the permanent removal of components from Wacker Neuson.
- Installing new components which are not from Wacker Neuson and not equivalent to the original parts in design and quality.
- Installation of accessories which are not from Wacker Neuson.

It is no problem to install spare parts from Wacker Neuson.

It is no problem to install accessories that are available in the Wacker Neuson product range of your machine. Please refer to the installation regulations in this operator's manual.

Do not drill into the housing, e.g. to install signs. Water could penetrate the housing and damage the machine.

### Requirements for operation

The ability to operate the machine safely requires:

- Proper transport, storage and setup.
- Careful operation.
- Careful service and maintenance.

### Operation

Operate the machine only as intended and only when in proper working condition.

Operate the machine in a safety-conscious manner with all safety devices attached and enabled. Do not modify or disable any safety devices.

Before starting operation, check that all control and safety devices are functioning properly.

Never operate the machine in a potentially explosive environment.

### Maintenance

Regular maintenance is required in order for the machine to operate properly and reliably over time. Failure to perform adequate maintenance reduces the safety of the machine.

- Strictly observe the prescribed maintenance intervals.
- Do not use the machine if it requires maintenance or repairs.

**Malfunctions**

If you detect a malfunction, you must shut down and secure the machine immediately.

Eliminate the malfunctions that impair safety immediately!

Have damaged or defective components replaced immediately!

For further information, refer to chapter *Malfunctions*.

**Spare parts, accessories**

Use only spare parts from Wacker Neuson or such that are equivalent to the original parts in design and quality.

Only use accessories from Wacker Neuson.

Non-compliance will exempt the manufacturer from all liability.

**Exclusion of liability**

Wacker Neuson will refuse to accept liability for injuries to persons or for damage to materials in the following cases:

- Structural modifications.
- Improper use.
- Failure to comply with this operator's manual.
- Improper handling.
- Using of spare parts which are not from Wacker Neuson and not equivalent to the original parts in design and quality.
- Using of accessories which are not from Wacker Neuson.

**Operator's manual**

Always keep the operator's manual near the machine or near the worksite for quick reference.

If you have misplaced the operator's manual or require an additional copy, contact your Wacker Neuson representative or download the operator's manual from the Internet ([www.wackerneuson.com](http://www.wackerneuson.com)).

Always hand over this operator's manual to other operators or to the future owner of the machine.

**Country-specific regulations**

Observe the country-specific regulations, standards and guidelines in reference to accident prevention and environmental safety, for example those pertaining to hazardous materials and wearing protective gear.

Complement the operator's manual with additional instructions taking into account the operational, regulatory, national or generally applicable safety guidelines.

### Operator's controls

Always keep the operator's controls of the machine dry, clean and free of oil or grease.

Operating elements such as ON/OFF switch, gas handles etc. may not be locked, manipulated or changed without authorization.

### Checking for signs of damage

Inspect the machine when it is switched off for any signs of damage at least once per work shift.

Do not operate the machine if there is visible damage or defects.

Have any damage or defects eliminated immediately.

### Supervision

Never leave the machine running unattended!

## 3.2 Qualification of the operating personnel

### Operator qualifications

Only trained personnel are permitted to start and operate the machine. The following rules also apply:

- You are physically and mentally fit.
- You have received instruction on how to independently operate the machine.
- You have received instruction in the proper use of the machine.
- You are familiar with required safety devices.
- You are authorized to start machines and systems in accordance with the standards governing safety.
- Your company or the operator has assigned you to work independently with this machine.

### Incorrect operation

Incorrect operation or misuse by untrained personnel can endanger the health and safety of the operator or third persons and also cause machine and material damage.

### Operating company responsibilities

The operating company must make the operator's manual available to the operator and ensure that the operator has read and understood it.

### Work recommendations

Please observe the recommendations below:

- Work only if you are in a good physical condition.
- Work attentively, particularly as you finish.
- Do not operate the machine when you are tired.
- Carry out all work calmly, circumspectly and carefully.
- Never operate the machine under the influence of alcohol, drugs or medication. This can impair your vision, reactions and your judgment.
- Work in a manner that does not endanger others.
- Ensure that no persons or animals are within the danger zone.

## 3.3 Protective gear

### Work clothing

Clothing should be appropriate, i.e. should be close-fitting but not restrict your movement.

When on construction sites, do not wear long hair loosely, loose clothing or jewelry including rings. These objects can easily get caught or be drawn in by moving machine parts.

Only wear clothing made of material that is not easily flammable.

### Personal protective gear

Wear personal protective gear to avoid injuries or health hazards:

- Non-skid, hard-toed shoes.
- Work gloves made of durable material.
- Overalls made of durable material.
- Hard hat.
- Ear protection.
- Face protection.
- Eye protection.
- Breathing protection in the case of dusty ambient air.

### Ear protection

This machine generates noise that exceeds the country-specific permissible noise levels (individual rating level). It may therefore be necessary to wear ear protection. You can find the exact value in the chapter *Technical Data*.

When wearing ear protection while working, you must pay attention and exercise caution because your hearing is limited, e.g. in case someone screams or a signal tone sounds.

Wacker Neuson recommends that you always wear ear protection.

### 3.4 Transport

#### Switching off the machine

Before you transport the machine, it must be switched off, and the engine must be given sufficient time to cool down.

#### Emptying the tank

Wacker Neuson recommends that the fuel tank be emptied and the carburetor run dry prior to transporting it. Fuel could run out, e.g. if the machine is tilted.

Observe the national safety guidelines and the hazardous materials regulations that apply to the respective means of transportation.

#### Transporting the machine

Secure the machine on the transport device against tilting, falling or slipping.

#### Lifting the machine

A falling machine can cause serious injuries.

The machine has no lifting or lashing points.

When lifting the machine, secure it in a closed transport container or similar in order to prevent it from toppling, falling or slipping away.

#### Restarting

Machines, machine parts, accessories or tools that were detached for transport purposes must be re-mounted and fastened before restarting.

Only operate in accordance with the operating instructions.

## 3.5 Operating safety

### Explosible environment

Never operate the machine in a potentially explosive environment.

### Work environment

Familiarize yourself with your work environment before you start work. This includes e.g. the following items:

- Obstacles in the work and traffic area.
- Load-carrying capacity of the ground.
- The measures needed to cordon off the construction site from public traffic in particular.
- The measures needed to secure walls and ceilings.
- Options available in the event of an accident.

### Safety in the work area

When working with the machine especially pay attention to the following points:

- Electric lines or pipes in work area.
- Gas lines or water lines in the work area.
- Material becoming separated, dropping down or ejected. Make sure that you do not put other persons in danger.
- Pay maximum attention in the vicinity of drops or slopes. Risk of falling.
- Maintain a sufficient distance from flammable materials.

### Checks before starting work

Check the following points before beginning work:

- Condition of tools.
- Machine settings.

### Starting the machine

Observe the safety information and warning notices located on the machine and in the operator's manual.

Never attempt to start a machine that requires maintenance or repairs.

Start the machine as described in the operator's manual.

### Vertical stability

Always make sure that you stand firmly when working with the machine. This applies particularly when working on scaffoldings, ladders, uneven or slippery floors etc.

### **Caution with hot parts**

Do not touch any hot parts such as tools, tool holders, mufflers or guide cylinders during operation or for a short period afterwards. These parts can become very hot and can cause severe burns.

### **Caution with movable parts**

Keep your hands, feet and loose clothing away from moving or rotating machine parts.

### **Caution with toxic materials**

Some materials may contain toxic chemicals which are released during demolition. Therefore personal protective equipment must be worn to prevent inhalation of and skin contact with work dust.

### **Do not direct towards people**

Do not direct the machine towards people in the vicinity during operation. The tool might be flung out and cause serious injuries.

### **No persons endangered**

Be sure that no persons are endangered by flying or falling materials. Always work very attentively, and anticipate potential hazards.

### **Switching off the machine**

Switch off the engine in the following situations:

- Before breaks.
- If you are not using the machine.

Before storing the machine, wait until it has completely stopped running.

Store the machine or put it down in such a way that it cannot tilt, fall down or slip.

### **Storage**

Set the machine down or store it securely so that it cannot tilt, fall down or slip.

### **Storage location**

After operation, allow the machine to cool and then store it in a sealed-off, clean and dry location protected against frost and inaccessible to children.



### **3.6 Safety during the operation of hand machines**

#### **Safe working with hand machines**

Secure loose workpieces with suitable methods.

While working, as a rule hold the machine on the provided handles with both hands.

While working, hold the machine in such a way that hand injuries are avoided when hitting hard objects.

#### **Setting the hand machine down properly**

Set the machine down carefully. Do not drop the machine to the floor or from greater heights. Dropping the machine can cause injuries to other persons or the machine itself can be damaged.

#### **Safe working with the hammer**

Keep the tool holder closed during operation.

### **3.7 Safety during the operation of combustion engines**

#### **Checking for signs of damage**

Check the engine while switched off for leaks and cracks in the fuel line, tank and fuel cap at least once per work shift.

Do not operate the machine if there is visible damage or defects.

Have any damage or defects eliminated immediately.

#### **Dangers during operation**

Combustion engines can be dangerous, particularly during operation and when refueling.

Read and follow all safety instructions. Otherwise there is a risk of personal injury and/or damage to property!

Do not start the engine near spilt fuel or if you smell fuel – this may cause an explosion!

- Remove the machine from such areas.
- Remove the spilt fuel immediately!

#### **Not changing the engine speed**

Do not change the preset engine speed, as this may cause engine damage.

### Preventing fires

Open flames and smoking are strictly prohibited in the immediate vicinity of the machine.

Make sure that waste, such as paper, dry leaves or grass do not accumulate around the exhaust muffler. The waste materials may ignite.

### Safety precautions when refueling

Please observe the following safety-relevant instructions when refueling:

- Do not refuel near open flames.
- Do not smoke.
- Turn off the engine before refueling and allow it to cool down.
- Refuel in a well-ventilated environment.
- Wear fuel-proof protective gloves and, if there is the possibility of spraying, protective goggles and clothing.
- Do not inhale fuel vapors.
- Avoid skin and eye contact with fuel.
- For refueling, use clean tools such as a hopper.
- Do not spill fuel, especially onto hot parts.
- Remove any spilt fuel immediately.
- Use the correct fuel grade.
- Do not mix fuel with other liquids.
- Fill the tank only up to the maximum marking. If there is no Maximum marking, do not fill up the tank completely.
- Lock the fuel cap securely after refueling.

### Operation in closed rooms

In closed or partially closed rooms such as tunnels, drifts or deep trenches, ensure sufficient ventilation by, for example, providing a powerful exhaust air fan.

**Danger of poisoning!** Do not inhale exhaust fumes. They contain toxic carbon monoxide that can lead to unconsciousness or death.

### Caution with hot parts

Do not touch any hot parts such as the engine block or exhaust muffler during operation or directly afterwards. These parts can become very hot and cause severe burns.

### **Not using starter sprays**

Highly flammable starter sprays pose a fire hazard.

Do not use any starter sprays.

Starter sprays are highly flammable and can cause backfiring and engine damage.

### **Shutting off the fuel tap**

When the machine stops, shut off the fuel tap.

### **Cleaning the engine**

Clean the engine when it is cool to remove any dirt.

Do not use gasoline or solvents. Danger of explosion!

### **Health hazard due to exhaust fumes**

Warning

The engine's exhaust fumes contain chemicals which are known to the State of California to cause cancer, congenital defects or other reproductive anomalies.

### **Notes on the EPA engine**

Caution

This machine is equipped with an EPA-certified engine.

Modifying the motor speed influences the EPA certification and emission. The motor may only be set by a skilled technician.

For more detailed information, contact your nearest motor or Wacker Neuson representative.

## **3.8 Maintenance**

### **Maintenance work**

Service and maintenance work must only be carried out to the extent described in these operating instructions. All other procedures must be performed by your Wacker Neuson representative.

For further information, refer to chapter *Maintenance*.

### **Switching off the engine**

Before carrying out care or maintenance work, switch off the engine and allow it to cool down.

For gasoline powered engines, you must pull off the spark plug cap.

### Handling operating fluids safely

Observe the following points when handling operating fluids, e.g. fuels, oils, greases, coolants etc.:

- Always wear personal safety clothing.
- Avoid skin and eye contact with operating fluids.
- Do not inhale or swallow operating fluids.
- In particular, avoid contact with hot operating fluids. Burn and scalding hazard.
- Dispose of replaced or spilled operating fluids according to the applicable regulations for environmental protection.
- If operating fluids escape from the machine, cease operation of the machine and have it repaired immediately by your Wacker Neuson representative.

### Cleaning

Always keep the machine clean and be sure to clean it each time you have finished using it.

Do not use gasoline or solvents. Danger of explosion!

Do not use high pressure washers. Permeating water can damage the machine. When electrical equipment is present, this can pose a serious injury risk from electric shocks.

### Cleaning the zerk fitting

Wipe the zerk fitting with a clean cloth after the lubrication of the machine. There is a danger of electrocution if there is excessive grease on the zerk fitting.

### 3.9 Safety devices



#### WARNING

Danger of injury due to open moving parts.

- ▶ Only operate the machine with properly installed and functioning safety devices.
- ▶ Do not modify or remove safety devices.



#### WARNING

Hot exhaust.

Touching it can cause burns.

- ▶ Only operate the machine with properly installed safety devices.
- ▶ Do not modify or remove safety devices.

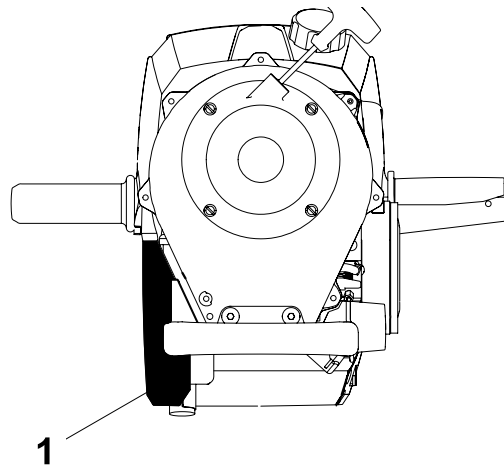

Item	Designation
1	Burn protector

#### Burn protector

The burn protector the operator against emitted heat.





## 4 Safety and information labels

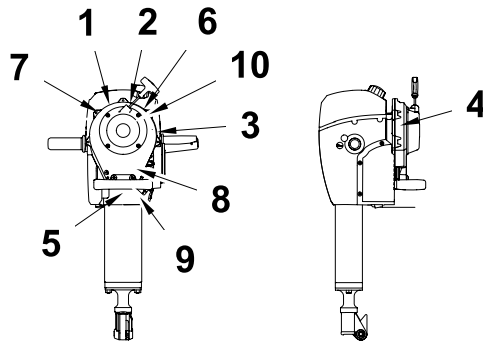

Your machine has adhesive labels containing the most important instructions and safety information.

- Make sure that all the labels are kept legible.
- Replace any missing or illegible labels.

The item numbers for the labels are in the parts book.

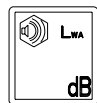

Item	Label	Description
1		Smoking and open flames are prohibited. Danger of fire.
2		Wear personal protective gear to avoid injuries or health hazards: Ear protection. Eye protection. Read the operator's manual.
3		OFF switch.
4		Caution. Warning of hot surface.
5		Guaranteed sound power level.

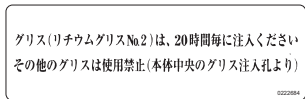
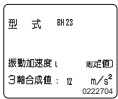
Item	Label	Description
6	US machines 	Warning.
7	US machines 	Danger.
8	Japan machines 	Use only specified spark plug.
9	Japan machines 	Grease every 20 hours with lithium grease. Do not use other grease. (grease at central grease point)
10	Japan machines 	Total vibration value of the acceleration.

### 5 Scope of delivery

The scope of delivery includes:

- Machine.
- Operator's manual.
- Parts book.



## 6 Structure and function

### 6.1 Application

Use the machine only as intended, see chapter *Safety, Proper use*.

### 6.2 Functional description

#### Principle

The machine is a demolition hammer with a pneumatic percussion system.

It is driven by a gasoline engine.

The rotary movement of the drive engine is converted into a stroke movement via a transmission and a crank gear.

The piston is moved forwards and backwards by the crank gear, this compresses the air (forward movement) or generates a partial vacuum (backward movement). Due to change in pressure the percussion piston is moved forward and backwards (air cushion percussion system) and hits the tool.

The hood and operator's controls are decoupled from the percussion system by a spring system. This spring system keeps vibrations away from the operator's body if he for example presses his body against the hood while working.

#### Integrated shut-off device – RS (optional)

The machine has an integrated shut-off device for connecting to an external remote cut-off.

Via the remote cut-off, you can switch off several machines from a central location. This is for the safety of the operators, e.g. in track construction work.

If you wish to use your machine with a remote cut-off, please contact your Wacker Neuson representative.

#### Low Vib (optional)

The machine has very low hand-arm vibration and allows fatigue-free working.

7 Components and operator's controls

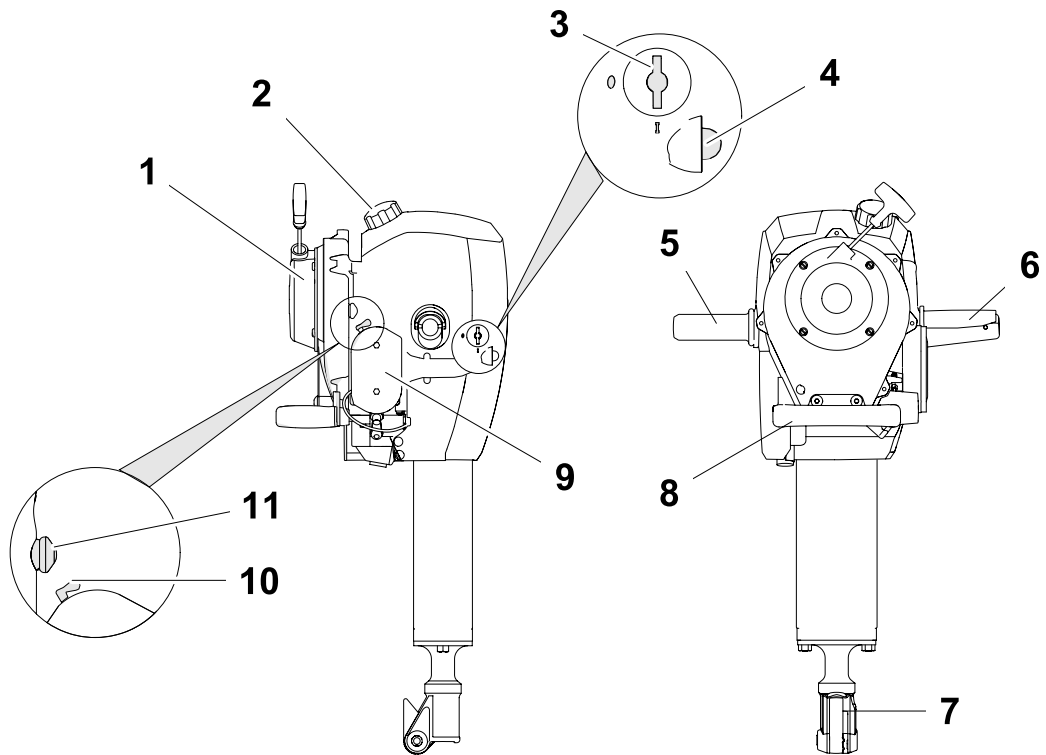

Item	Designation	Item	Designation
1	Recoil starter	7	Tool holder
2	Fuel cap	8	Supplementary handle
3	Fuel tap	9	Air cleaner
4	Fuel pump	10	Choke
5	Handle	11	OFF switch
6	Gas handle		

**Recoil starter**

The recoil starter starts the engine.

In certain operating situations, e.g. when ramming in posts and grounding rods, it can be advantageous to change the traction direction of the recoil starter, i.e. the position of the recoil starter should be different to the standard position. In such cases, consult the Service Department of your Wacker Neuson representative.

### Gas handle

The gas handle has several positions:

- **Idle position**

Gas handle in its original position, not pressed.

Engine running at idle speed.

Percussion system disengaged and does not strike.

- **Working position**

The machine is pressed against the material when the gas handle is pressed.

Engine running at maximum speed.

Percussion system engaged and strikes.

- **Machine raised**

Machine is raised from the material when the gas handle has been pressed.

Engine speed limited at high speed.

Percussion system engaged, but does not strike.

### Tool holder

The tool holder is used to hold the tool.

### Supplementary handle

The supplementary handle simplifies working in a tilted position.

Wacker Neuson recommends to carry the machine using the supplementary handle.

### Fuel tap

The fuel tap opens or closes the fuel supply.

### OFF switch

The Off switch deactivates the machine.

### Choke

When the engine is cold or hot, also activate the choke in order to enrich the fuel-air mixture.

### Fuel pump

The fuel pump is used to fill the fuel lines and the carburetor after the machine has not been used for a while. The integrated return pipe prevents too much fuel from entering the carburetor as a result of excessive pumping.

### 8 Transport



---

**WARNING**

Improper handling can result in injury or serious material damage.

- ▶ Read and follow all safety instructions of this operator's manual, see chapter *Safety*.
- 



---

**WARNING**

Danger of fire and explosions by fuel.

Any fuel that escapes can ignite and cause severe burns.

- ▶ Lift and move the machine in the upright position.
- 

#### Performing preparations

1. Switch off the engine.
2. Remove tool.
3. Lean the machine upright against a solid object and secure it to prevent it from toppling over.  
Wacker Neuson recommends to hang the machine on the truck.
4. Let machine cool off.

#### Emptying the fuel system

**Note:** The fuel cap has a pressure relief and vacuum valve through which fuel can escape when it is warm (e.g. in direct sunlight).

The fuel system must be empty during transport in order to prevent fuel from escaping through the pressure relief valve.

1. Remove any dirt around the fuel cap.
2. Unscrew and remove fuel cap.
3. Pump the fuel out into a suitable container or tank, e.g. with a suction pump.
4. Position the fuel cap and tighten it.
5. Start the engine and let it idle until the fuel in the carburetor is used up and the engine stops.

#### Transporting the machine

1. Lift machine with the supplementary handle.
2. Place the machine on or into a suitable means of transport.
3. Secure the machine against falling over and down or sliding.

**Note:** Wacker Neuson recommends to use the truck for the transport on the construction site, refer to chapter *Accessories*.

## 9 Initial start up

### Rendering the machine functional

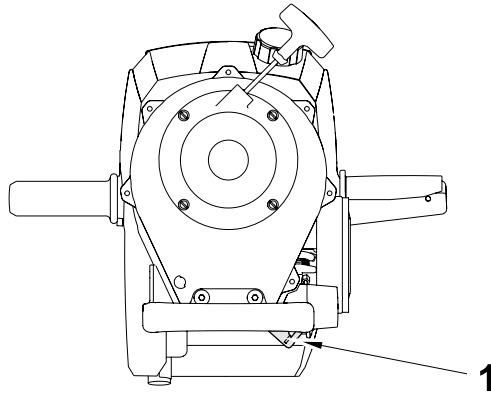

Item	Designation
1	Spark plug cap

- ▶ Place the spark plug cap onto the spark plug.

## 10 Use and operation

---



### **WARNING**

Improper handling can result in injury or serious material damage.

- ▶ Read and follow all safety instructions of this operator's manual, see chapter *Safety*.
- 

### 10.1 Prior to starting the machine

#### Checking the machine

Check the following points before beginning work:

- ▶ Damage to the machine and to all components.

If the machine is damaged, do not start the machine. Have any damage or defects eliminated immediately.

- ▶ Fuel level, see chapter *Maintenance*.
- ▶ Air cleaner, see chapter *Maintenance*.
- ▶ Recoil starter, see chapter *Maintenance*.

## 10.2 Adjusting the machine

### Machine with integrated shut-off device – RS (optional)

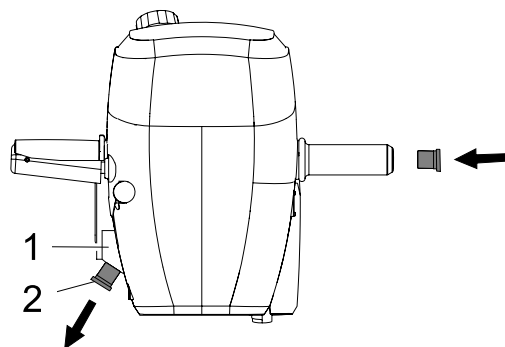

Item	Designation	Item	Designation
1	Shorting plug	3	Handle
2	Shorting plug		

The machine only works when either the plug of the remote cut-off or the shorting plug is plugged in at the connection socket of the integrated shut-off device.

#### Operation with remote cut-off

If you wish to operate the machine via an external remote cut-off:

1. Remove the shorting plug from the connection socket.
2. Plug the shorting plug into the handle opposite so that it does not get lost.

The machine is now ready for operation with the remote cut-off. For further information, see the remote cut-off operator's manual.

#### Operation without remote cut-off

If you wish to operate the machine without an external remote cut-off:

1. Remove the shorting plug from the handle opposite.
2. Plug the shorting plug into the connection socket.

The machine is now ready for operation with the remote cut-off.

### 10.3 Changing tools

#### General notes

You can change the tool without additional tools.

#### Notes on using tools

Only use tools with the following properties:

- The tool must be suitable for the tool holder.
- The tool end must be undamaged.
- The tool must be sufficiently sharp to avoid impact damage.
- The tool must be suitable for the intended application.

#### Inserting tool

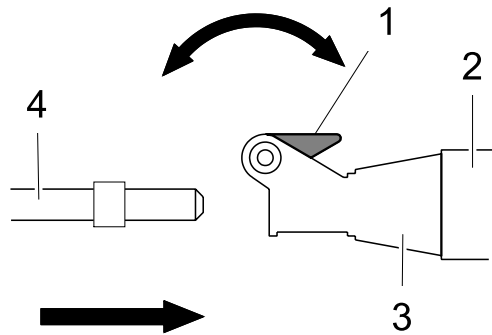

Item	Designation	Item	Designation
1	Handle	3	Tool holder
2	Guide cylinder	4	Tool

1. Clean tool end.
2. Swivel out handle on the tool holder.
3. Turn the tool into the position which is most suitable for the intended work.
4. Push tool into the tool holder as far as it will go.
5. Press the handle on the tool holder.
6. Check to see if the tool is locked by pulling on the tool.



### Removing tool



---

#### **CAUTION**

Risk of burn injury from a hot tool and guide cylinder.

- ▶ Touch the tool only if you are wearing protective gloves.
- 

1. Swivel out handle on the tool holder.
2. Remove tool from the tool holder.
3. Press the handle on the tool holder.

## 10.4 Starting up

### Work tips

- When working, use the weight of the hammers.
- Pressing forcefully against the material to be worked on does not improve the machine's performance.
- Press the machine against the material to be worked as follows:
  - Press with sufficient strength that the machine noticeably locks into place.
  - Apply somewhat less pressure as soon as you feel the lower stop.

### Notes for operation below freezing point

The cold grease in the percussion system may increase the resistance to such an extent that the centrifugal clutch slips.

- ▶ Allow the machine to warm up at low engine speed (do not press the gas handle) to prevent the centrifugal clutch from premature wear.

### 10.4.1 Starting the engine

**Note:** When starting the engine, move to a position at least 3 m (9.8 ft) from the fueling area.

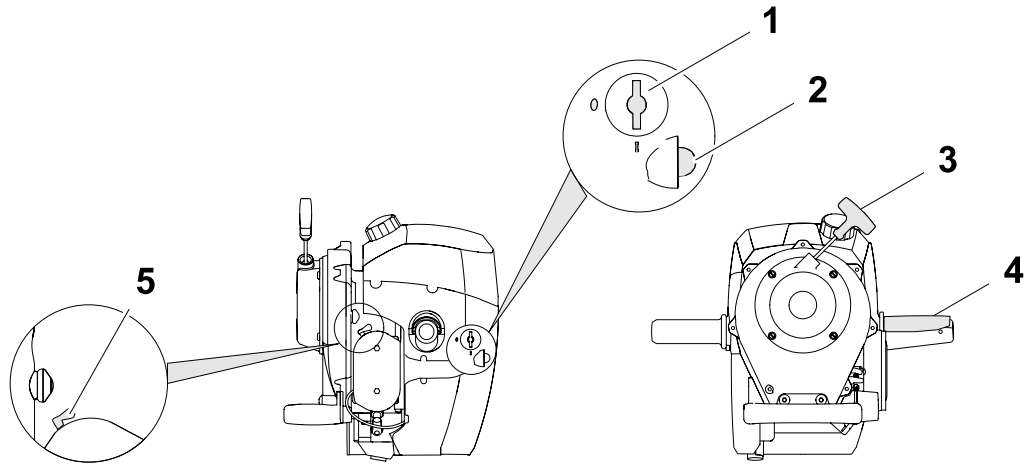

Item	Designation	Item	Designation
1	Fuel tap	4	Throttle lever
2	Fuel pump	5	Choke
3	Starter rope		

### Performing preparations

1. Put the machine into an upright position and hold it with one hand.
2. Open the fuel tap.

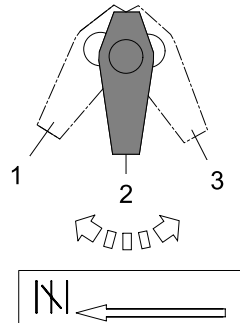

Item	Designation	Item	Designation
1	Choke active	3	Choke inactive
2	Choke halfway position		

3. Cold motor: Activate choke.  
Warm engine: Deactivate choke.  
Hot engine: Activate choke.
4. Press the fuel pump bellows repeatedly until the bellows is completely filled with fuel.

### Starting the engine

---

**NOTICE**

Improper handling can damage the machine.

- ▶ Do not pull the starter rope as far as it can go.
  - ▶ Let starter rope slowly roll back in.
- 



---

**CAUTION**

Incorrect handling during starting can result in minor injuries.

- ▶ Do not pull the starter rope until sufficient space is available and nobody is in the immediate vicinity.
- 

1. Press down the gas handle (full throttle position).
2. Pull out the starter rope slowly until compression resistance can be felt and then let it slowly roll back in again.
3. Pull the starter rope firmly, but not suddenly (several times if necessary).
4. Let starter rope slowly roll back in.
5. Deactivate the choke when you hear the engine's first ignition.
6. Pull the starter rope with force, but not suddenly (several times, if necessary) until the engine starts.
7. Let starter rope slowly roll back in.
8. Release the gas handle (idle position).
9. Allow the engine to warm up.

## 10.5 Operating the machine

### Processing material



#### WARNING

Injuries from insufficiently guided or uncontrolled machine.

- ▶ Always hold machine with both hands and stand firmly.

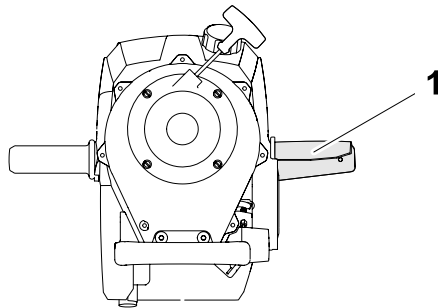

Item	Designation
1	Gas handle

1. Hold the machine firmly with both hands.
2. Place the tool into position on the material.
3. Press down the gas handle.
4. With both hands, press the machine against the material to be processed.
 

**Note:** Press with sufficient strength that you feel the machine's spring system, but not the lower stop.
5. When the material has been processed, lift and adjust the machine.

**Note:** Proceed as follows if the tool gets stuck in the material:

- Open the tool holder and remove the tool.
- Continue working with another tool.
- When the machine is lifted and the gas handle is pressed, the engine continues to run at a high speed, while the percussion system remains engaged.
- When the tool has no resistance, the percussion system goes over to idle operation and no longer impacts.

#### **Note for breaking off edges**

Pay attention to the following points when breaking off edges:

- Vertical stability.

### 10.6 Decommissioning

#### Switching off the machine

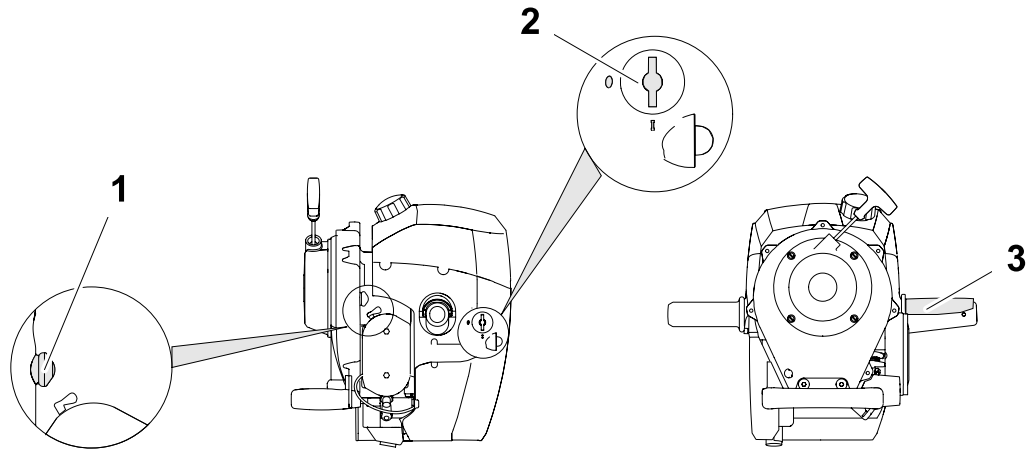

Item	Designation	Item	Designation
1	OFF switch	3	Gas handle
2	Fuel tap		

1. Release the gas handle.
2. Keep the off switch pressed until the machine has come to a complete standstill.
3. Close the fuel tap.
4. Set down the machine in such a way that it cannot tilt, fall or slip.

## 11 Maintenance



---

**WARNING**

Improper handling can result in injury or serious material damage.

- ▶ Read and follow all safety instructions of this operator's manual, see chapter *Safety*.
- 



---

**WARNING**

Danger of poisoning by exhaust fumes.

Exhaust fumes contain toxic carbon monoxide that can lead to unconsciousness or death.

- ▶ Carry out maintenance work only when the engine is off.
- 

### 11.1 Maintaining the emission control system

Normal maintenance, replacement or repair of emission control devices and systems may be performed by any repair establishment or individual; however, warranty repairs must be performed by a dealer/service center authorized by Wacker Neuson.

The use of service parts that are not equivalent in performance and durability to authorized parts may impair the effectiveness of the emission control system and may have a bearing on the outcome of a warranty claim.

### 11.2 Maintenance personnel qualifications

#### Qualifications for maintenance work

The maintenance work described in this operator's manual may be performed by any responsible user unless otherwise stated.

Some maintenance work may only be performed by specially trained personnel or by the service staff of your Wacker Neuson contact — these are specifically noted.

## 11.3 Maintenance schedule

Task	Daily before operation	Every 20 hrs.	Monthly	Annually
Visual inspection of all parts for damage.	■			
Clean the machine. ■ Ventilation slots. ■ Air cleaner.	■			
Check the fuel: ■ Fuel tank fill level. ■ Fuel tank for leaks. ■ Lines for leaks.	■			
Check the tool ends and cutting edges – if required, sharpen, reforge or replace.	■			
Lubricate the machine.		■		
Clean spark plug – change, if necessary.			■	
Check tool holder for wear – have it changed, if necessary. *			■	
Have the fuel filter replaced. *				■

\* Have these tasks carried out by the service department of your Wacker Neuson contact person.

## 11.4 Maintenance work

### Working in the workshop

Perform maintenance work in a workshop on a workbench. This has the following benefits:

- Protection of the machine of contamination on the construction site.
- A level and clean work surface makes work easier.
- There is a better overview over small parts and they are not lost as easily.

### 11.4.1 Cleaning machine

Clean the machine after use.

1. Clean the ventilation slots with a suitable tool.
2. Wipe the housing with a damp and clean cloth.



### 11.4.2 Topping up with fuel



---

**WARNING**

Danger of fire and explosions by fuel and fuel vapors.

- ▶ Do not smoke.
  - ▶ Do not refuel near open flames.
  - ▶ Turn off the engine before refueling and allow it to cool down.
- 



---

**CAUTION**

Health hazard due to fuel.

- ▶ Refuel in a well-ventilated environment.
  - ▶ Do not inhale fuel vapors.
  - ▶ Avoid skin and eye contact with fuel.
-

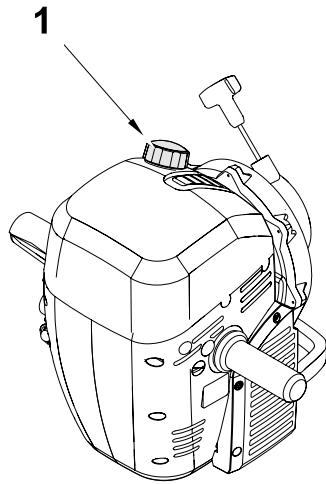

Item	Designation
1	Fuel cap

### Performing preparations

1. Switch off the engine.
2. Lean the machine upright against a solid object and secure it to prevent it from toppling over.  
Wacker Neuson recommends to hang the machine on the truck.
3. Let machine cool off.

### Topping up with fuel

1. Remove any dirt around the fuel cap.
2. Slowly unscrew and remove fuel cap.

**Note:** Slowly unscrew the fuel cap so that any overpressure can slowly escape.

3. Use a clean funnel to replenish fuel.

See chapter *Technical data* for the fuel specification.  
See chapter *Technical data* for the fuel mixing table.

4. Position the fuel cap and tighten it.

### 11.4.3 Checking/cleaning air cleaner

#### Performing preparations

1. Switch off the engine.
2. Lean the machine upright against a solid object and secure it to prevent it from toppling over.  
Wacker Neuson recommends to hang the machine on the truck.
3. Let machine cool off.

#### Removing the air cleaner cartridge

1. Remove any dirt around the air cleaner cap.
2. Unscrew and remove all nuts of the air cleaner cap with a screw wrench.
3. Remove the air cleaner cap.
4. Remove air cleaner cartridge.

#### Checking/cleaning air cleaner cartridge

- ▶ Tap out air cleaner cartridge and blow out from inside to outside with compressed air.

**Note:** When tapping, make sure that the air cleaner cartridge is not damaged.

If the dust can no longer be removed, change the air cleaner cartridge.

#### Installing air cleaner cartridge

1. Insert air cleaner cartridge.
2. Replace air cleaner cap.
3. Tighten all nuts of the air cleaner cap securely with a screw wrench.

---

#### NOTICE

Operating the engine without air cleaner can cause rapid engine wear.

- ▶ Do not run the engine without an air cleaner or air cleaner cap.
-

### 11.4.4 Lubricating the machine

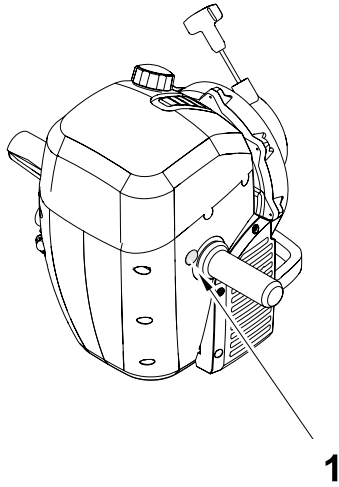

Item	Designation
1	Zerk fitting

1. Remove any dirt around the zerk fitting.
2. Place filled manual grease gun onto the zerk fitting and operate approx. 20 times.  
**Note:** Only use special lubricants for lubricating, see chapter *Technical Data*.
3. Wipe the area around the zerk fitting with a clean cloth.

### 11.4.5 Checking/cleaning/replacing spark plug



#### CAUTION

Touching a hot spark plug can cause burns.

- ▶ Only remove the spark plug when the engine has cooled down.

#### Performing preparations

1. Switch off the engine.
2. Let machine cool off.

#### Removing the spark plug

1. Clean around the spark plug thoroughly.
2. Pull off the spark plug cap from the spark plug.

**Note:** Do not pull the spark plug cap off the spark plug by the ignition cable.

3. Loosen and unscrew the spark plug with a spark plug wrench.

#### Checking/cleaning the spark plug

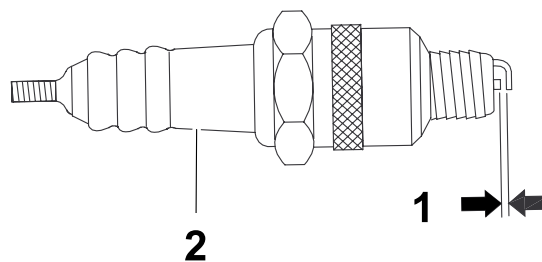

Item	Designation	Item	Designation
1	Spark plug air gap	2	Isolator

1. Check the isolator – if damaged, replace the spark plug.
2. Clean the electrodes with a wire brush.
3. Measure the spark plug gap with a feeler gauge – if necessary, correct it by bending the lateral electrode.  
See the chapter *Technical data* for the spark plug and electrode gap.
4. Check the spark plug gasket – if damaged, replace the spark plug.

### Installing the spark plug

1. First screw in the spark plug manually then tighten it with a spark plug wrench.  
Torque 22 Nm (16 lbf ft).
2. Place the spark plug cap onto the spark plug.

---

#### NOTICE

A spark plug that is too loose or too tight can damage the engine.

- ▶ Tighten the spark plugs with the specified torque.
- 

### 11.4.6 Checking the tool holder for wear

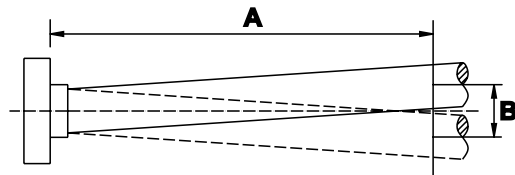

Item	Value
A	200 mm (0.66 ft)
B	Max. 6 mm (0.02 ft)

1. Insert the tool.  
**Note:** Use a new tool to measure only the wear of the tool holder and not the wear of the tool.
  2. Measure the tool play 200 mm (0.66 ft) from insertion point.  
Play may not exceed 6 mm (0.05 ft).
- If the play exceeds 6 mm, the tool holder must be replaced.

## 12 Malfunctions

Potential faults, their causes and remedies can be found in the following table.

Notify your Wacker Neuson contact in case of malfunctions you cannot or may not remedy yourself.

Malfunction	Cause	Remedy	
Engine does not start.	Fuel tap is closed.	Open the fuel tap.	
	Fuel tank is empty.	Top up with fuel.	
	Fuel line is clogged.	Have the fuel line cleaned. *	
	Fuel filter is clogged.	Have the fuel filter replaced. *	
	Carburetor is clogged.	Have the carburetor cleaned. *	
	Air cleaner is clogged.	Clean air cleaner.	
	Spark plug cap is defective.	Have the machine repaired. *	
	Spark plug is defective.	Change the spark plug.	
	Spark plug is loose.	Tighten the spark plug.	
	Spark plug gap is set incorrectly.	Set the spark plug gap.	
	The connection socket of the remote cut-off is empty.		Connect remote cut-off.
			Insert shorting plug.
Remote cut-off is not functioning properly.		Check remote cut-off according to the manufacturer's instructions.	
Engine shuts off right after starting.	Fuel tank is empty.	Top up with fuel.	
	Fuel filter is clogged.	Have the fuel filter replaced. *	
	Air cleaner is dirty.	Clean or replace air cleaner.	
Engine has low performance.	Air cleaner is dirty.	Clean or replace air cleaner.	
Recoil starter defective.	Starter rope jammed.	Have the starter rope replaced. *	
	Starter rope torn off.		

\* Have these tasks carried out by the service department of your Wacker Neuson contact person.

## 13 Storage



---

### **WARNING**

Danger of fire and explosions by fuel.

Any fuel that escapes can ignite and cause severe burns.

- ▶ Lift and move the machine in the upright position.
- 

If the machine will not be operated for a while, e.g. during the winter, do the following:

### **Performing preparations**

1. Switch off the engine.
2. Remove tool.
3. Lean the machine upright against a solid object and secure it to prevent it from toppling over.  
Wacker Neuson recommends to hang the machine on the truck.
4. Let machine cool off.

### **Emptying the fuel system**

The gasoline in the fuel partially evaporates during long-term storage. The two-cycle oil in the fuel does not evaporate. After long-term storage the mixture ratio of gasoline to two-cycle oil is no longer correct. For this reason, the fuel system must be empty for long-term storage.

1. Remove any dirt around the fuel cap.
2. Unscrew and remove fuel cap.
3. Pump the fuel out into a suitable container or tank, e.g. with a suction pump.
4. Position the fuel cap and tighten it.
5. Start the engine and let it idle until the fuel in the carburetor is used up and the engine stops.

### **Storing the machine**

1. Clean the machine.
2. Oil areas such as the tool holder and the handle, where there is a risk of rusting.
3. Store the machine in a dry place.



## 14 Accessories

There is a wide range of accessories available for the machine.

For more information on the individual accessories, visit the following website:  
[www.wackerneuson.com](http://www.wackerneuson.com).

### 14.1 Truck

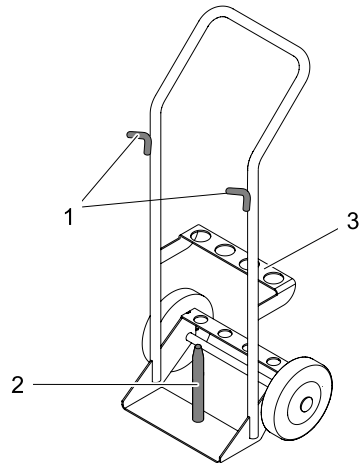

Item	Designation
1	Hanging device
2	Guide rod
3	Tool holder

#### Proper use

The truck must only be used for the transport of Wacker Neuson large hammers and the required tools.

The truck must not be used for the following:

- Transporting people.
- Transporting other machines except Wacker Neuson large hammers.

The truck must not be attached to vehicles.

### Placing hammer on the truck



---

**CAUTION**

Insufficient stability of the truck.

Injury or damage caused by the truck tipping over or rolling off when the hammer is placed on it.

- ▶ Place truck on a level surface.
  - ▶ Secure truck against rolling off and tipping over.
- 

1. Switch off the machine.
2. Remove tool from the tool holder.
3. Clean the truck's guide rod.
4. Insert hammer with the tool holder on the guide rod and rest on the handles of the truck.
5. Insert tool in the tool holder.

## 15 Technical data

### 15.1 BH 23

#### Machine

Designation	Unit	BH 23				
Item no.		0610381 0610410	0610377	0610378	0610379	0610380
Length x Width x Height	mm (ft)	777 x 492 x 346 (2.5 x 1.6 x 1.1)			833 x 492 x 346 (2.7 x 1.6 x 1.1)	
Operating weight	kg (lb)	23 (51)	24 (53)		25 (55)	
Percussion rate	min <sup>-1</sup> (rpm)	1,300				
Single stroke energy	J	55				
Tool holder		∅ 27x80	hex 25x108	hex 28x152	hex 28x160	
Special lubricating grease		Retinax LX2 grease				
Sound power level L <sub>WA</sub> *	dB(A)	108				
Sound pressure level L <sub>pA</sub> at operator's station **	dB(A)	101				
Total vibration value of the acceleration a <sub>hv</sub> ***	m/s <sup>2</sup> (in/s <sup>2</sup> )	12 (472)				
Uncertainty of measure- ment of the vibration total value of the acceleration ahv	m/s <sup>2</sup> (in/s <sup>2</sup> )	3,0 (118)				

\* According to DIN EN ISO 3744.

\*\* According to DIN EN ISO 11201.

\*\*\* Determined according to DIN EN ISO 5349.

**Drive engine**

Designation	Unit	BH 23
Manufacturer		Wacker Neuson
Engine type		WM 80
Combustion method		2-cycle
Engine type		Gasoline engine
Engine displacement	cm <sup>3</sup> (in <sup>3</sup> )	80 (4.9)
Rated output*	kW	1,6
Rated speed	min <sup>-1</sup> (rpm)	4,250
Idle speed	min <sup>-1</sup> (rpm)	1,800–2,000
Operating fluid		Gasoline-oil mixture or 2-cycle prepared mixture Aspen
Fuel specification		Regular gasoline, lead-free 91 ROZ (87 R+M)
Oil specification, 2-cycle oil		NMMA TC-W3, JASO FC, JASO FD, ISO EGC, ISO EGD
Gasoline/2-cycle oil mixing ratio		50:1 (100:1)
Fuel consumption	l/h (gal/h)	0.9 (0.24)
Tank capacity	l (gal)	1.8 (0.48)
Cooling system		Air cooling
Spark plug		Bosch WR 7 AC Champion RL 86 C
Spark plug air gap	mm (in)	0.5 (0.02)

\* According to DIN ISO 3046-1.

## 15.2 BH 24

## Machine

Designation	Unit	BH 24				
Item no.		0610382	0610384	0610385	0610383	0610386
Length x Width x Height	mm (ft)	848 x 492 x 346 (2.8 x 1.6 x 1.1)	905 x 492 x 346 (3.0 x 1.6 x 1.1)		858 x 492 x 346 (2.8 x 1.6 x 1.1)	905 x 492 x 346 (3.0 x 1.6 x 1.1)
Operating weight	kg (lb)	25 (55)	26 (57)		25 (55)	26 (57)
Percussion rate	min <sup>-1</sup> (rpm)	1,250				
Single stroke energy	J	65				
Tool holder		∅ 27x80	hex 28x152	hex 28x160	hex 25x108	hex 32x160
Special lubricating grease		Retinax LX2 grease				
Sound power level L <sub>WA</sub> *	dB(A)	108,5				
Sound pressure level L <sub>pA</sub> at operator's station **	dB(A)	101				
Total vibration value of the acceleration a <sub>hv</sub> ***	m/s <sup>2</sup> (in/s <sup>2</sup> )	6 (236)				
Uncertainty of measure- ment of the vibration to- tal value of the accelera- tion a <sub>hv</sub>	m/s <sup>2</sup> (in/s <sup>2</sup> )	1,0 (39)				

\* According to DIN EN ISO 3744.

\*\* According to DIN EN ISO 11201.

\*\*\* Determined according to DIN EN ISO 5349.

**Machine**

Designation	Unit	BH 24 Low Vib				
Item no.		0610388 0610393*	0610390	0610391	0610389	0610392
Length x Width x Height	mm (ft)	842 x 492 x 346 (2.8 x 1.6 x 1.1)	898 x 492 x 346 (2.9 x 1.6 x 1.1)		852 x 492 x 346 (2.8 x 1.6 x 1.1)	898 x 492 x 346 (2.9 x 1.6 x 1.1)
Operating weight	kg (lb)	25 (55)	26 (57)		25 (55)	26 (57)
Percussion rate	min <sup>-1</sup> (rpm)	1,350				
Single stroke energy	J	55				
Tool holder		∅ 27x80	hex 28x152	hex 28x160	hex 25x108	hex 32x160
Special lubricating grease		Retinax LX2 grease				
Sound power level L <sub>WA</sub> **	dB(A)	108,5				
Sound pressure level L <sub>pA</sub> at operator's station ***	dB(A)	101				
Total vibration value of the acceleration a <sub>hv</sub> ****	m/s <sup>2</sup> (in/s <sup>2</sup> )	4,9 (193)				
Uncertainty of measure- ment of the vibration total value of the acceleration ahv	m/s <sup>2</sup> (in/s <sup>2</sup> )	0,5 (20)				

\* Remote cut-off (RS).

\*\* According to DIN EN ISO 3744.

\*\*\* According to DIN EN ISO 11201.

\*\*\*\*Determined according to DIN EN ISO 5349.

## Drive engine

Designation	Unit	BH 24	BH 24 Low Vib
Manufacturer		Wacker Neuson	
Engine type		WM 80	
Combustion method		2-cycle	
Engine type		Gasoline engine	
Engine displacement	cm <sup>3</sup> (in <sup>3</sup> )	80 (4.9)	
Rated output*	kW	1,7	1,6
Rated speed	min <sup>-1</sup> (rpm)	4,100	4,500
Idle speed	min <sup>-1</sup> (rpm)	1,800–2,000	
Operating fluid		Gasoline-oil mixture or 2-cycle prepared mixture Aspen	
Fuel specification		Regular gasoline, lead-free 91 ROZ (87 R+M)	
Oil specification, 2-cycle oil		NMMA TC-W3, JASO FC, JASO FD, ISO EGC, ISO EGD	
Gasoline/2-cycle oil mixing ratio		50:1 (100:1)	
Fuel consumption	l/h (gal/h)	1.1 (0.29)	0.9 (0.24)
Tank capacity	l (gal)	1,8 (0.48)	
Cooling system		Air cooling	
Spark plug		Bosch WR 7 AC Champion RL 86 C	
Spark plug air gap	mm (in)	0.5 (0.02)	

\* According to DIN ISO 3046-1.

15.3 BH 65

Machine

Designation	Unit	BH 65
Item no.		0610387
Length x Width x Height	mm (ft)	905 x 492 x 346 (3.0 x 1.6 x 1.1)
Operating weight	kg (lb)	26 (57)
Percussion rate	min <sup>-1</sup> (rpm)	1,250
Single stroke energy	J	65
Tool holder		hex 28x152
Special lubricating grease		Retinax LX2 grease
Sound power level $L_{WA}$ *	dB(A)	108,5
Sound pressure level $L_{pA}$ at operator's station **	dB(A)	101
Total vibration value of the acceleration $a_{hv}$ ***	m/s <sup>2</sup> (in/s <sup>2</sup> )	6 (236)
Uncertainty of measurement of the vibration total value of the acceleration $a_{hv}$	m/s <sup>2</sup> (in/s <sup>2</sup> )	1,0 (39)

\* According to DIN EN ISO 3744.

\*\* According to DIN EN ISO 11201.

\*\*\* Determined according to DIN EN ISO 5349.



## Drive engine

Designation	Unit	BH 65
Manufacturer		Wacker Neuson
Engine type		WM 80
Combustion method		2-cycle
Engine type		Gasoline engine
Engine displacement	cm <sup>3</sup> (in <sup>3</sup> )	80 (4.9)
Rated output*	kW	1,7
Rated speed	min <sup>-1</sup> (rpm)	4,100
Idle speed	min <sup>-1</sup> (rpm)	1,800–2,000
Operating fluid		Gasoline-oil mixture or 2-cycle prepared mixture Aspen
Fuel specification		Regular gasoline, lead-free 91 ROZ (87 R+M)
Oil specification, 2-cycle oil		NMMA TC-W3, JASO FC, JASO FD, ISO EGC, ISO EGD
Gasoline/2-cycle oil mixing ratio		50:1 (100:1)
Fuel consumption	l/h (gal/h)	1.1 (0.29)
Tank capacity	l (gal)	1,8 (0.48)
Cooling system		Air cooling
Spark plug		Bosch WR 7 AC Champion RL 86 C
Spark plug air gap	mm (in)	0.5 (0.02)

\* According to DIN ISO 3046-1.

## 16 Emission control systems information and warranty

The Emission Control Warranty and associated information is valid only for the U.S.A., its territories, and Canada.

### 16.1 Emission control system background information

#### Introduction

Wacker Neuson spark-ignited engines/equipment must conform with applicable Environmental Protection Agency (EPA) and the State of California emissions regulations. There are two types of emissions that fall under these regulations: 1) exhaust, and 2) evaporative. These regulations require that manufacturers warrant the emission control systems for defects in materials and workmanship. Furthermore, EPA and California regulations require all manufacturers to furnish written instructions describing how to operate and maintain the engines/equipment including the emission control systems. This information is provided with all Wacker Neuson engines/equipment at the time of purchase.

#### Exhaust emissions

The combustion process produces carbon monoxide, oxides of nitrogen, and hydrocarbons. Control of hydrocarbons and oxides of nitrogen is very important because, under certain conditions, they react to form photochemical smog when subjected to sunlight. Carbon monoxide does not react in the same way, but it is toxic.

Wacker Neuson utilizes lean carburetor settings and other systems to reduce the emissions of carbon monoxide, oxides of nitrogen, and hydrocarbons.

#### Evaporative emissions

Evaporative emissions are fuel emissions and generally include emissions that result from permeation of fuel through the fuel-system materials or from ventilation of the fuel system.

Wacker Neuson utilizes low-permeation fuel lines and fuel tanks where applicable to reduce evaporative emissions.

Problems that may affect Emissions

If any of the following symptoms arise, have the engine/equipment inspected and repaired by a Wacker Neuson dealer/service center.

- Hard starting or stalling after starting
- Rough idling
- Misfiring or backfiring under load
- Afterburning (backfiring)
- Presence of black exhaust smoke during operation
- High fuel consumption

### **Tampering and altering**

Tampering with or altering the emission control system may increase emissions beyond the legal limit. If evidence of tampering is found, Wacker Neuson may deny a warranty claim. Among those acts that constitute tampering are:

- Removing or altering of any part of the air intake, fuel, or exhaust systems.
- Altering or defeating the speed-adjusting mechanism causing the engine to operate outside its design parameters.

### **16.2 Limited defect warranty for Wacker Neuson emission control systems**

The Emission Control Warranty is valid only for the U.S.A., its territories, and Canada.

Wacker Neuson Sales Americas, LLC, N92 W15000 Anthony Avenue, Menomonee Falls, WI 53051, (hereinafter “Wacker Neuson”) warrants to the initial retail purchaser, and each subsequent owner, that this engine/equipment, including all parts of its emission control systems, have been designed, built, and equipped to conform at the time of initial sale to all applicable emission regulations of the U.S. Environmental Protection Agency (EPA), and that the engine/equipment is free of defects in materials and workmanship which would cause this engine/equipment to fail to conform to EPA regulations during its warranty period.

Wacker Neuson is also liable for damages to other engine/equipment components caused by a failure of any warranted parts during the warranty period.

#### **Limited defect warranty period for Wacker Neuson emission control systems**

The warranty period for this engine/equipment begins on the date of sale to initial purchaser and continues for a minimum of two (2) years. For the warranty terms for your specific engine/equipment, visit [www.wackerneuson.com](http://www.wackerneuson.com).

Any implied warranties are limited to the duration of this written warranty.

**What is covered**

Wacker Neuson recommends the use of genuine Wacker Neuson parts, or the equivalent, whenever maintenance is performed. The use of replacement parts not equivalent to the original parts may impair the effectiveness of the engine/equipment emission controls systems. If such a replacement part is used in the repair or maintenance of the engine/equipment, assure yourself that such part is warranted by its manufacturer to be equivalent to the parts offered by Wacker Neuson in performance and durability. Furthermore, if such a replacement part is used in the repair or maintenance of the engine/equipment, and an authorized Wacker Neuson dealer/service center determines it is defective or causes a failure of a warranted part, the claim for repair of the engine/equipment may be denied. If the part in question is not related to the reason the engine/equipment requires repair, the claim will not be denied.

For the components listed in the following table, an authorized Wacker Neuson dealer/service center will, at no cost to you, make the necessary diagnosis, repair, or replacement necessary to ensure that the engine/equipment complies with the applicable EPA regulations. All defective parts replaced under this warranty become property of Wacker Neuson.

**Exhaust emissions**

Systems Covered	Components
Fuel metering system	<ul style="list-style-type: none"> <li>■ Carburetor and internal parts</li> <li>■ Air/fuel ratio feedback system (if applicable)</li> <li>■ Cold start enrichment system (if applicable)</li> <li>■ Regulator assembly (if applicable)</li> </ul>
Exhaust system	<ul style="list-style-type: none"> <li>■ Catalytic muffler (if applicable)</li> <li>■ Exhaust manifold (if applicable)</li> </ul>
Air induction system	<ul style="list-style-type: none"> <li>■ Air filter housing</li> <li>■ Air filter element *</li> <li>■ Intake manifold (if applicable)</li> </ul>
Ignition system	<ul style="list-style-type: none"> <li>■ Flywheel magneto</li> <li>■ Ignition module</li> <li>■ Electronic controls (if applicable)</li> <li>■ Spark advance/retard system (if applicable)</li> <li>■ Spark plug cap</li> <li>■ Spark plug *</li> </ul>

Systems Covered	Components
Miscellaneous parts associated with the exhaust emission control system	<ul style="list-style-type: none"> <li>■ Tubing</li> <li>■ Fittings</li> <li>■ Seals</li> <li>■ Gaskets</li> <li>■ Clamps</li> </ul>

\* Indicates expendable maintenance items. Warranted only to first scheduled replacement point.

### Evaporative emissions

Systems Covered	Components
Evaporative control system	<ul style="list-style-type: none"> <li>■ Fuel tank (if applicable)</li> <li>■ Fuel tank cap (if applicable)</li> <li>■ Fuel line (if applicable)</li> <li>■ Fuel line fittings (if applicable)</li> <li>■ Clamps (if applicable)</li> <li>■ Carbon canister (if applicable)</li> <li>■ Purge port connector (if applicable)</li> </ul>
Miscellaneous parts associated with the evaporative emission control system	<ul style="list-style-type: none"> <li>■ Clamps</li> <li>■ Gaskets</li> <li>■ Mounting brackets</li> </ul>

### What is not covered

Failures other than those resulting from defects in material or workmanship.

- Any systems or parts which are affected or damaged by owner abuse, tampering, neglect, improper maintenance, misuse, improper fueling, improper storage, accident and/or collision; the incorporation of, or any use of, add-on or modified parts, or unsuitable attachments, or the alteration of any part.
- Replacement of expendable maintenance items made in connection with required maintenance services after the item's first scheduled replacement as listed in the maintenance section of the engine/equipment operator's manual, such as spark plugs and filters.
- Incidental or consequential damages such as loss of time or the use of the engine/equipment, or any commercial loss due to the failure of the engine/equipment.
- Diagnosis and inspection charges that do not result in warranty-eligible service being performed.
- Any non-authorized replacement part, or malfunction of authorized parts due to use of non-authorized parts.

### Owner's warranty responsibility

The engine/equipment owner is responsible for the performance of the required maintenance listed in the Wacker Neuson engine/equipment operator's manual.

Wacker Neuson recommends that all receipts covering maintenance on the engine/equipment be retained, but Wacker Neuson cannot deny warranty coverage solely for the lack of receipts or for the failure to ensure the performance of all scheduled maintenance.

Normal maintenance, replacement, or repair of emission control devices and systems may be performed by any repair establishment or individual; however, warranty repairs must be performed by an authorized Wacker Neuson dealer/service center.

The engine/equipment must be presented to an authorized Wacker Neuson dealer/service center as soon as a problem exists. Contact Wacker Neuson Product Support Department (1-800-770-0957) or visit [www.wackerneuson.com](http://www.wackerneuson.com) to find a dealer/service center in your area, or to answer questions regarding warranty rights and responsibilities.

### How to make a claim

In the event that any emission-related part is found to be defective during the warranty period, you shall notify Wacker Neuson Product Support Department (1-800-770-0957), and you will be advised of the appropriate dealer/service center where warranty repair can be performed. All repairs qualifying under this limited warranty must be performed by an authorized Wacker Neuson dealer/service center.

You must take your Wacker Neuson engine/equipment along with proof of original purchase date, at your expense, to the authorized Wacker Neuson dealer/service center during their normal business hours.

For owners located more than 100 miles from an authorized dealer/service center (excluding the states with high-altitude areas as identified in 40 CFR Part 1068, Appendix III), Wacker Neuson will pay for pre-approved shipping costs to and from an authorized Wacker Neuson dealer/service center.

Claims for repair or adjustment found to be caused solely by defects in material or workmanship will not be denied because the engine/equipment was not properly maintained and used.

The warranty repairs should be completed in a reasonable amount of time, not to exceed 30 days.



## 17 Glossary

### 17.1 Use of oxygenated fuels

Some conventional gasolines are blended with alcohol. These gasolines are collectively referred to as oxygenated fuels. If you use an oxygenated fuel, be sure it is unleaded and meets the minimum octane rating requirement.

Before using an oxygenated fuel, confirm the fuel's contents. Some states / Provinces require this information to be posted on the fuel pump.

The following are Wacker Neuson approved percentages of oxygenates:

**Ethanol** - (ethyl or grain alcohol) 10% by volume. You may use gasoline containing up to 10% ethanol by volume (commonly referred to as E10). Gasoline containing more than 10% ethanol (such as E15, E20, or E85) may not be used because it could damage the engine.

**Methanol** - (methyl or wood alcohol) 5% by volume. You may use gasoline containing up to 5% methanol by volume, as long as it contains cosolvents and corrosion inhibitors to protect the fuel system. Gasoline containing more than 5% methanol by volume may cause starting and/or performance problems. It may also damage metal, rubber, and plastic parts of your fuel system.

If you notice any undesirable operating symptoms, try another service station, or switch to another brand of gasoline.

Fuel system damage or performance problems resulting from the use of an oxygenated fuel containing more than the percentages of oxygenates mentioned above are not covered under warranty.







## EC Declaration of Conformity

### Manufacturer

Wacker Neuson SE  
Preußenstraße 41, 80809 München

### Product

Type		BH 23			BH 24	
Product type		Demolition hammer				
Item no.		0610381	0610377, 0610378	0610379, 0610380	0610382, 0610383, 0610388, 0610393, 0610389	0610384, 0610385, 0610386, 0610390, 0610391, 0610392
Weight	kg	23 (51)	24 (53)	25 (55)		26 (57)
Measured sound power level	dB(A)	108			108,5	
Guaranteed sound power level	dB(A)	109				

**Conformity assessment procedure** in accordance with 2000/14/EC, Appendix VIII, 2005/88/EC

### Guidelines and standards

This is to certify that this product meets and complies with the relevant regulations and requirements of the following guidelines and standards:

2006/42/EC,

2004/108/EC, EN 55012:2007

**Authorized representative for technical documentation:** Axel Häret

Munich, 17/03/2010

Franz Beierlein  
Head of product management

Dr. Michael Fischer  
Head of Research and Development





