

BRISE-BETON - DEMOLITION HAMMER - AUFBRUCHHAMMER

MARTELLLO DEMOLITORE - ROMPEDORES

MK210 - MK250

	MK210	MK250
Poids / weight / Gewicht / Peso / Peso (Kg / Lb)	21 / 46,30	25 / 55,10
Longueur / length / Gesamtlänge / Lunghezza / Longitud (mm)	685	735
Alésage / Bore / Bohrung duchmesser /Alesaggio / Escariado (mm)	Ø : 55	Ø : 55
Course piston / Piston stroke / Kolbenhub / Corsa del pistone Carrera del piston (mm)	118	118
Cadence de frappe / B.P.M. / Schlagzahl / Colpi Golpes por minuto (cps/min.)	1380	1380
Pression / Pressure / Betriebsdruck / Pressione / Presion (Bar/PSI)	6 / 87	6 / 87
Emmanchement / Sleeve fitting / Einsteckende / immanicatura Enmangadura (mm / in)	H. 25,6x108 H. 1"x4"1/4	H. 28,5x160 H. 1"1/8x6"1/4
Emmanchement option / Optional sleeve fitting / Einsteckende wahlweise Immanicatura opzionale / Enmangadura opcional (mm / in)		H. 31,7x160 H. 1"1/4x6"1/4
Consommation / Air consumption / Luftverbrauch / Consumo aria Consumo de aire (l/mn / CFM)	1100 / 38,50	1250 / 43,75
Flexible / Hose / Schlauch anschluss / Manguera (mm / in)	Ø : 19 / 3/4"	Ø : 19 / 3/4"
Puissance acoustique / Acoustic power / Schall-Leistung / Potenza acustica Potencia acustica [Lw / dB(A)]	<107	<107
Niveau sonore / Sound level / Schallpegel / Livello sonoro Nivel sonoro [dB (A)]*	92,6	94,4
Vibrations / Vibrations / Vibrationen / Vibrazioni / Vibraciones (m/s2) (ISO 8662-5)	<4	<4

* Niveau sonore mesuré à l'oreille de l'opérateur. -Noise emission level measured at operator's ear.-Geräuschpegel am Ohr des Bedieners. - Misurato presso l'orecchio dell'operatore. -Nivel de ruido medido en la oreja del operador.

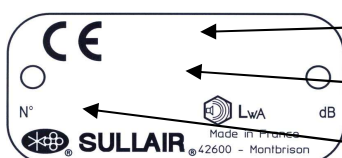

REFERENCE / REFERENCIA / BEZUGNAHME / RIFERIMENTO / REFERENCIA

DESIGNATION / DESIGNACION / BENNENUNG / DESIGNAZIONE / DESIGNACION

N° DE SERIE / SERIAL NUMBER / SERIENNUMMER / N° DI SERIE / N° DE SERIE

Réf.68724116-01

Date dernière mise à jour : 06 - 2010

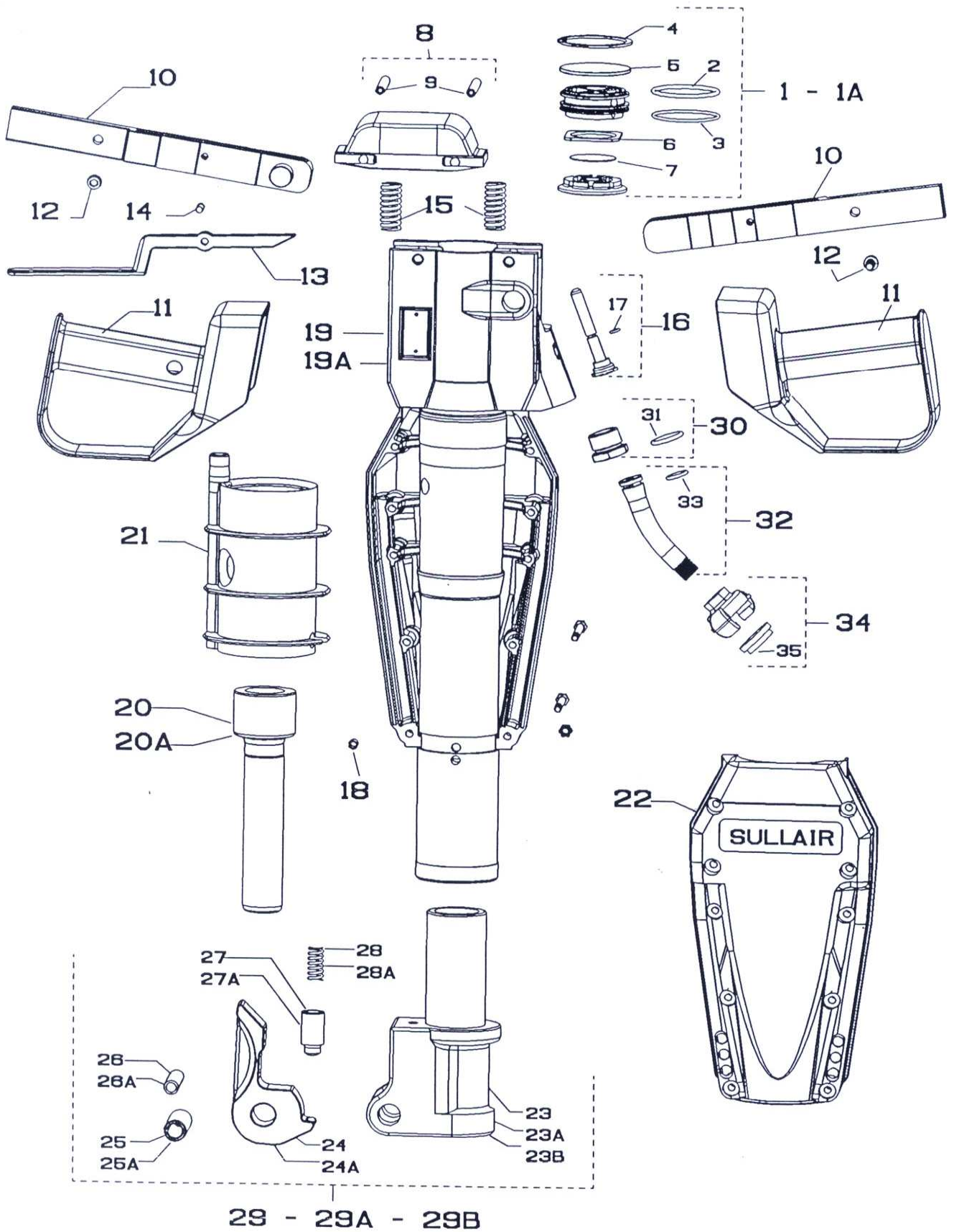

8	68780287	1	Kit couvercle:	Cover kit:	Deckel kit:	Kit coperchio:	Kit tapa:
9	68524695	2	-Goupille	-Pin	-Spindel	-Perno	-Eje
10	68723135	2	Poignée	Handle	Handgriff	Manico	Empunadura
11	68723145	2	Garniture	Gasket	Dichtung	Guarnizione	Junta
12	68532710	2	Vis	Screw	Schraube	Vite	Tornillo
13	68723136	1	Gachette	Trigger	Drücker	Grilletto	Gatillo
14	68723154	1	Axe cannelé	Pin	Spindel	Perno	Eje
15	68524717	2	Ressort	Spring	Feder	Molla	Muelle
16	* 68780285	1	Kit soupape :	Valve kit :	Einlasschieber Kpl :	Kit valvola :	Kit valvula :
17	68CJ 0005	1	-Joint	-Gasket	-Dichtung	-Giunto	-Junta
18	68524700	1	Goupille	Pin	Spindel	Perno	Eje
21	68723139	1	Chemise	Insulating sleeve	Büchse	Manicotto	Mango
22	68780286	1	Kit atténuateur:	Muffler kit:	Dämpfer kit:	Kit attenuatore:	Kit atenuador:
30	68780247	1	Kit écrou :	Nut kit :	Mutter kit :	Kit dado :	Kit tuerca :
31	68CJ 0018	1	-Joint	-Gasket	-Dichtung	-Giunto	-Junta
32	* 68780299	1	Kit raccord tournant :	Swivel fitting kit :	Schlauchanshuss kit :	Kit raccordo girevole :	Kit codo admision :
33	68CJ 0012	1	-Joint	-Gasket	-Dichtung	-Giunto	-Junta
34	* 68524603	1	Raccord express:	Quick fit connection:	Schnelkupplung:	Raccordo rapido:	Racor conexion rapida:
35	68524400	1	-Joint	-Gasket	-Dichtung	-Giunto	-Junta

MK210: Emmanchement 25 x 108

1	* 68780301	1	Kit distribution:	Distribution kit:	Verteiler kit:	Distribuzione completa:	Distribucioun completo:
2	68524693	1	-Joint	-Gasket	-Dichtung	-Giunto	-Junta
3	68524692	1	-Joint	-Gasket	-Dichtung	-Giunto	-Junta
4	68524694	1	-Circlips	-Circlips	-Circlips	-Circlips	-Circlips
5	68723144	1	-Entretoise	-Distance piece	-Distanzstück	-Distanziale	-Riostra
6	68723143	1	-Plaque épaisseur	-Plate	-Platte	-Piastra	-Placa
7	68723142	1	-Pastille	-Insert	-Steuerscheibe	-Pastilla	-Pastiglia
19	68723156	1	Cylindre MK210	Cylinder MK210	Zylinder MK210	Cilindro MK210	Cilindro MK210
20	68723158	1	Piston	Piston	Kelben	Pistone	Embolo
29	68780298	1	Kit manchon chape:	Fronthead kit:	Klinkenhalter kit:	Manicotto forcella completa:	Mango revestimiento completo:
23	68723166	1	-Manchon chape	-Frontead	-Klinkenhalter	-Manicotto forcella	-Mango revestimiento
24	* 68723212	1	-Loquet	-Latch	-Klinke	-Spagnoletta	-Pestillo
25	* 68521668	1	-Goupille	-Pin	-Spindel	-Perno	-Eje
26	* 68524011	1	-Goupille	-Pin	-Spindel	-Perno	-Eje
27	* 68722737	1	-Taquet	-Dog	-Klinkenhalterbolzen	-Tacchetto	-Tope
28	* 68MR 0707	1	-Ressort	-Spring	-Feder	-Molla	-Muelle

* pièces recommandées pour votre stock

* recommended parts for your stock

* empfohlene Bevorratungs-teile

* pezzi raccomandati per il vostro stock

* Piezas aconsejadas para vuestro stock

DESIGNATION

DESIGNATION

BENENNUNG

DESIGNAZIONE

DESIGNACION



MK210 -MK250

07-2007

MK250: Emmanchement 28,5 x 160

1A	* 68780284	1	Kit distribution:	Distribution kit:	Verteiler kit:	Distribuzione completa:	Distribuciun completo:
2	68524693	1	-Joint	-Gasket	-Dichtung	-Giunto	-Junta
3	68524692	1	-Joint	-Gasket	-Dichtung	-Giunto	-Junta
4	68524694	1	-Circlips	-Circlips	-Circlips	-Circlips	-Circlips
5	68723144	1	-Entretoise	-Distance piece	-Distanzstück	-Distanziale	-Riostra
6	68723143	1	-Plaque épaisseur	-Plate	-Platte	-Piastra	-Placa
7	68723142	1	-Pastille	-Insert	-Steuerscheibe	-Pastilla	-Pastiglia
19A	68723137	1	Cylindre MK250	Cylinder MK250	Zylinder MK250	Cilindro MK250	Cilindro MK250
20A	68723569	1	Piston	Piston	Kelben	Pistone	Embolo
29A	68780146	1	Kit manchon chape:	Fronthead kit:	Klinkenhalter kit:	Manicotto forcella completa:	Mango revestimien completo:
23A	68722581	1	-Manchon chape	-Frontead	-Klinkenhalter	-Manicotto forcella	-Mango revestimiento
24A	* 68723244	1	-Loquet	-Latch	-Klinke	-Spagnoletta	-Pestillo
25A	* 68780320	1	-Kit Goupille	-Pin Kit	-Spindel Kit	-Kit Perno	-Kit Eje
26A							
27A	* 68722586	1	-Taquet	-Dog	-Klinkenhalterbolzen	-Tacchetto	-Tope
28A	* 68MR 1301	1	-Ressort	-Spring	-Feder	-Molla	-Muelle

MK250: Emmanchement 31,7 x 160

1A	* 68780284	1	Kit distribution:	Distribution kit:	Verteiler kit:	Distribuzione completa:	Distribuciun completo:
2	68524693	1	-Joint	-Gasket	-Dichtung	-Giunto	-Junta
3	68524692	1	-Joint	-Gasket	-Dichtung	-Giunto	-Junta
4	68524694	1	-Circlips	-Circlips	-Circlips	-Circlips	-Circlips
5	68723144	1	-Entretoise	-Distance piece	-Distanzstück	-Distanziale	-Riostra
6	68723143	1	-Plaque épaisseur	-Plate	-Platte	-Piastra	-Placa
7	68723142	1	-Pastille	-Insert	-Steuerscheibe	-Pastilla	-Pastiglia
19A	68723137	1	Cylindre MK250	Cylinder MK250	Zylinder MK250	Cilindro MK250	Cilindro MK250
20A	68723569	1	Piston	Piston	Kelben	Pistone	Embolo
29B	68780147	1	Kit manchon chape:	Fronthead kit:	Klinkenhalter kit:	Manicotto forcella completa:	Mango revestimiento completo:
23B	68722579	1	-Manchon chape	-Frontead	-Klinkenhalter	-Manicotto forcella	-Mango revestimiento
24A	* 68723244	1	-Loquet	-Latch	-Klinke	-Spagnoletta	-Pestillo
25A	* 68780320	1	-Kit Goupille	-Pin Kit	-Spindel Kit	-Kit Perno	-Kit Eje
26A							
27A	* 68722586	1	-Taquet	-Dog	-Klinkenhalterbolzen	-Tacchetto	-Tope
28A	* 68MR 1301	1	-Ressort	-Spring	-Feder	-Molla	-Muelle

* pièces recommandées pour votre stock

* recommended parts for your stock

* empfohlene Bevorratungs-teile

* pezzi raccomandati per il vostro stock

* Piezas aconsejadas para vuestro stock

DESIGNATION

DESIGNATION

BENNENUNG

DESIGNAZIONE

DESIGNACION



MK210 -MK250

07-2007