

# Repair Manual

## Rammer

**BS 50 / BS 60 / BS 70**

**BS 500 / BS 600 / BS 700**

**BS 65 / BS 650**

**DS 70 / DS 720**



0114549en	010	0510
-----------	-----	------



0 1 1 4 5 4 9 E N

**Copyright  
notice**

© Copyright 2010 by Wacker Neuson Corporation.

All rights, including copying and distribution rights, are reserved.

This publication may be photocopied by the original purchaser of the machine. Any other type of reproduction is prohibited without express written permission from Wacker Neuson Corporation.

Any type of reproduction or distribution not authorized by Wacker Neuson Corporation represents an infringement of valid copyrights. Violators will be prosecuted.

---

**Trademarks**

All trademarks referenced in this manual are the property of their respective owners.

---

**Manufacturer**

Wacker Neuson Corporation

N92W15000 Anthony Avenue

Menomonee Falls, WI 53051 U.S.A.

Tel: (262) 255-0500 · Fax: (262) 255-0550 · Tel: (800) 770-0957

[www.wackerneuson.com](http://www.wackerneuson.com)

---

## Foreword

Machines covered in this manual.

BS 50-4	0009386, 0009415, 0620108, 0620071, 0620077, 0620078
BS 50-2	0009380, 0009382, 0009384, 0009410, 0009411, 0009413, 0620025, 0620048, 0620609, 0620610, 0620733, 0620609, 0620610, 0620733
BS 50-2i	0009332, 0009338, 0009383, 0009412, 0009414, 0009416, 0009473, 0620026, 0620611
BS 500	0007550, 0008048, 0008049, 0008204, 0009074, 0009075
BS 500-4	0009329
BS 500-oi	0009165, 0009343
BS 500S	0009211
BS 60-4	0009340, 0009422, 0620000, 0620051, 0620109, 0620110, 0620072, 0620073, 0620074, 0620483, 0620563, 0620812, 0620813, 0620816, 0620819, 0620820
BS 60-2	0009388, 0009391, 0009417, 0009418, 0009421, 0620612
BS 60-2i	0009339, 0009393, 0009419, 0009420, 0620613, 0620614
BS 600	0007551, 0008205, 0008207, 0009076, 0009077, 0009307
BS 600-4	0009331
BS 600-oi	0009166, 0009262
BS 600S	0009212
BS 70-2	0009397, 0009399, 0009424, 0009425, 0009427
BS 70-2i	0009341, 0009401, 0009426, 0009428
BS 700	0007552, 0008051, 0008052, 0008206, 0009078, 0009079, 0009308
BS 700-oi	0009167, 0009328
BS 65-V	0009396, 0009423
BS 650	0008209
DS 70	0009342, 0009402, 0009403, 0620049, 0620050, 0620052, 0620053, 0620054

### Machine documentation

- Keep a copy of the Operator's Manual with the machine at all times.
- Use the separate Parts Book supplied with the machine to order replacement parts.
- If you are missing any of these documents, please contact Wacker Neuson Corporation to order a replacement or visit [www.wackerneuson.com](http://www.wackerneuson.com).
- When ordering parts or requesting service information, be prepared to provide the machine model number, item number, revision number, and serial number.

## Foreword

### Expectations for information in this manual

- This manual provides information and procedures to safely operate and maintain the above Wacker Neuson model(s). For your own safety and to reduce the risk of injury, carefully read, understand, and observe all instructions described in this manual.
- Wacker Neuson Corporation expressly reserves the right to make technical modifications, even without notice, which improve the performance or safety standards of its machines.
- The information contained in this manual is based on machines manufactured up until the time of publication. Wacker Neuson Corporation reserves the right to change any portion of this information without notice.

---

### CALIFORNIA Proposition 65 Warning

Engine exhaust, some of its constituents, and certain vehicle components, contain or emit chemicals known to the State of California to cause cancer and birth defects or other reproductive harm.

---

### Laws pertaining to spark arresters

**NOTICE:** State Health Safety Codes and Public Resources Codes specify that in certain locations spark arresters be used on internal combustion engines that use hydrocarbon fuels. A spark arrester is a device designed to prevent accidental discharge of sparks or flames from the engine exhaust. Spark arresters are qualified and rated by the United States Forest Service for this purpose. In order to comply with local laws regarding spark arresters, consult the engine distributor or the local Health and Safety Administrator.

---

### Manufacturer's approval

This manual contains references to *approved* parts, attachments, and modifications. The following definitions apply:

- **Approved parts or attachments** are those either manufactured or provided by Wacker Neuson.
- **Approved modifications** are those performed by an authorized Wacker Neuson service center according to written instructions published by Wacker Neuson.
- **Unapproved parts, attachments, and modifications** are those that do not meet the approved criteria.

Unapproved parts, attachments, or modifications may have the following consequences:

- Serious injury hazards to the operator and persons in the work area
- Permanent damage to the machine which will not be covered under warranty

Contact your Wacker Neuson dealer immediately if you have questions about approved or unapproved parts, attachments, or modifications.

<b>Foreword</b>	<b>3</b>
<b>1 Safety Information</b>	<b>9</b>
1.1 Signal Words Found in this Manual .....	9
1.2 Machine Description and Intended Use .....	10
1.3 Operating Safety .....	11
1.4 Operator Safety while using Internal Combustion Engines .....	13
1.5 Service Safety .....	14
<b>2 Tools</b>	<b>17</b>
2.1 Recommended Special Tools .....	17
2.2 Recommended Repair Tools .....	18
<b>3 Maintenance Schedules</b>	<b>19</b>
3.1 Periodic Maintenance Schedule (BS 50/60/70-2, BS 65) .....	19
3.2 Periodic Maintenance Schedule (BS 500/600/700/650) .....	20
3.3 Periodic Maintenance Schedule (BS 50/60/70-2i) .....	21
3.4 Periodic Maintenance Schedule (BS 500/600/700-oi) .....	22
3.5 Periodic Maintenance Schedule (DS 70) .....	23
3.6 Periodic Maintenance Schedule (DS 720) .....	24
<b>4 Engine and Upper Machine Components</b>	<b>25</b>
4.1 Removing the Silencing Cover .....	25
4.2 Replacing the Throttle Control (2010 and later 2-stroke models) .....	26
4.3 Replacing the Throttle Control (2010 4-stroke models) .....	28
4.4 Throttle Control (pre-2010 models) .....	31
4.5 Replacing the Stop Switch (2010 and later 2-stroke models) .....	32
4.6 Replacing the Stop Switch (2010 and later 4-stroke models) .....	35
4.7 Replacing the Guide Handle (2010 and later 2-stroke models) .....	37
4.8 Replacing the Guide Handle (2010 and later 4-stroke models) .....	40
4.9 Replacing the Guide Handle (pre-2010 models) .....	44
4.10 Shock Mounts .....	45

4.11	Tillotson Carburetor (BS 500/600/700/650 only) .....	46
4.12	Fuel Lines (BS 50/60/70-2, BS 65) .....	48
4.13	Fuel Tank (BS Models) .....	49
4.14	Fuel Tank (DS Models) .....	50
4.15	Fuel Tank Cap .....	52
4.16	Muffler (pre-2009 BS Models) .....	54
4.17	Engine Cooling Fins .....	55
4.18	Muffler (DS Models) .....	56
4.19	Replacing the Carburetor (WM 80 engines) .....	58
4.20	Replacing the WM 80 Engine (2010 and later models) .....	62
4.21	Replacing the WM 80 Engine (pre-2010 models) .....	64
4.22	Replacing the Carburetor (WM 100 Engines) .....	66
4.23	Replacing the WM 100 Engine .....	70
4.24	Removing the WM 90 Engine .....	74
4.25	Engine (DS Models) .....	76
4.26	Clutch (2- and 4-stroke models) .....	78
4.27	Clutch (DS 720 only) .....	80
4.28	Clutch (DS 70 only) .....	82

**5 Ramming System 84**

5.1	Bellows .....	84
5.2	Replacing the Ramming Shoe .....	87
5.3	Spring System Cover Removal and Installation .....	90
5.4	Spring System .....	96
5.5	Inspecting the Spring System .....	98
5.6	Protective Pipe .....	99
5.7	Ramming System Lubrication (BS 500/600/700/650, DS 720) .....	100
5.8	Ramming System Lubrication (BS 50/60/70, BS 65, DS 70) .....	102

**6 Crankcase 104**

6.1	Crank Gear and Connecting Rod .....	104
6.2	Crank Gear, Connecting Rod, and Adjuster Assembly (BS 650/65 only) .....	106
6.3	Clutch Drum .....	110

<b>7</b>	<b>Oil Injection (if equipped)</b>	<b>112</b>
7.1	Testing the Float Switch (2010 and later models) .....	112
7.2	Replacing the Float Switch (2010 and later models) .....	114
7.3	Float Switch Testing and Replacement (pre-2010 models) .....	116
7.4	Oil Line Check Valve .....	118
7.5	Oil Pump / Cartridge Assembly .....	120
<b>8</b>	<b>Low Oil Shutdown (if equipped)</b>	<b>123</b>
8.1	Testing the Low Oil Unit .....	123
<b>9</b>	<b>Troubleshooting</b>	<b>124</b>
9.1	Engine Hard to Start .....	124
9.2	Engine Does Not Start .....	125
9.3	Engine Does Not Accelerate or Runs Poorly .....	125
9.4	Engine Overheats .....	126
9.5	Rammer Does Not Tamp .....	126
9.6	Rammer Jumps Erratically .....	127
<b>10</b>	<b>Technical Data</b>	<b>128</b>
10.1	BS 50-2 .....	128
10.2	BS 50-4 .....	129
10.3	BS 500 .....	130
10.4	BS 500S .....	131
10.5	BS 50-2i .....	132
10.6	BS 500-oi .....	133
10.7	BS 60/70-2 .....	134
10.8	BS 60-4 .....	135
10.9	BS 600/700 .....	136
10.10	BS 600S .....	137
10.11	BS 60/70-2i .....	138
10.12	BS 600/700-oi .....	139
10.13	BS 600/700 High Altitude .....	140
10.14	BS 65-V .....	141
10.15	BS 650 .....	142

10.16 DS 70 ..... 144  
10.17 DS 720 ..... 146



## 1 Safety Information

### 1.1 Signal Words Found in this Manual

This manual contains **DANGER**, **WARNING**, **CAUTION**, **NOTICE**, and **NOTE** signal words which must be followed to reduce the possibility of personal injury, damage to the equipment, or improper service.



This is the safety alert symbol. It is used to alert you to potential personal hazards.  
 ► Obey all safety messages that follow this symbol.



#### **DANGER**

**DANGER** indicates a hazardous situation which, if not avoided, will result in death or serious injury.

- To avoid death or serious injury from this type of hazard, obey all safety messages that follow this signal word.



#### **WARNING**

**WARNING** indicates a hazardous situation which, if not avoided, could result in death or serious injury.

- To avoid possible death or serious injury from this type of hazard, obey all safety messages that follow this signal word.



#### **CAUTION**

**CAUTION** indicates a hazardous situation which, if not avoided, could result in minor or moderate injury.

- To avoid possible minor or moderate injury from this type of hazard, obey all safety messages that follow this signal word.

**NOTICE:** Used without the safety alert symbol, **NOTICE** indicates a situation which, if not avoided, could result in property damage.

**Note:** A Note contains additional information important to a procedure.

## 1.2 Machine Description and Intended Use

This machine is a vibratory rammer. The Wacker Neuson Rammer consists of a gasoline or diesel engine, a clutch, a fuel tank, a spring-loaded ramming system, a ramming shoe, and a handle. The engine transmits power through the ramming system and ramming shoe, generating percussive impact force to compact soil. The operator guides and controls the machine from behind using the handle.

This machine is intended to be used for compacting cohesive, mixed, and granular soils in confined areas.

This machine has been designed and built strictly for the intended use described above. Using the machine for any other purpose could permanently damage the machine or seriously injure the operator or other persons in the area. Machine damage caused by misuse is not covered under warranty.

The following are some examples of misuse:

- Using the machine as a ladder, support, or work surface
- Using the machine to carry or transport passengers or equipment
- Using the machine as a hammer or for other demolition work
- Attaching the machine to any other machine
- Operating the machine outside of factory specifications
- Operating machine in a manner inconsistent with all warnings found on the machine and in the Operator's Manual

This machine has been designed and built in accordance with the latest global safety standards. It has been carefully engineered to eliminate hazards as far as practicable and to increase operator safety through protective guards and labeling. However, some risks may remain even after protective measures have been taken. They are called residual risks. On this machine, they may include exposure to:

- Heat, noise, exhaust, and carbon monoxide from the engine
- Fire hazards from improper refueling techniques
- Fuel and its fumes
- Personal injury from improper lifting techniques or operating techniques

To protect yourself and others, make sure you thoroughly read and understand the safety information presented in this manual before operating the machine.

## 1.3 Operating Safety

### Operator qualifications

Only trained personnel are permitted to start, operate, and shut down the machine. They also must meet the following qualifications:

- have received instruction on how to properly use the machine
- are familiar with required safety devices

The machine must not be accessed or operated by:

- children
- people impaired by alcohol or drugs

### Operator training

Before operating the machine:

- Read and understand the operating instructions contained in all manuals delivered with the machine.
- Familiarize yourself with the location and proper use of all controls and safety devices.
- Contact Wacker Neuson Corporation for additional training if necessary.

When operating this machine:

- Do not allow improperly trained people to operate the machine. People operating the machine must be familiar with the potential risks and hazards associated with it.

### Personal Protective Equipment (PPE)

Wear the following Personal Protective Equipment (PPE) while operating this machine:

- Close-fitting work clothes that do not hinder movement
- Safety glasses with side shields
- Hearing protection
- Safety-toed footwear

- 1.3.1 Never operate this machine in applications for which it is not intended.
- 1.3.2 Do not allow anyone to operate this equipment without proper training. People operating this equipment must be familiar with the risks and hazards associated with it.
- 1.3.3 Do not touch the engine or muffler while the engine is on or immediately after it has been turned off. These areas get hot and may cause burns.
- 1.3.4 Do not operate the machine with unapproved accessories or attachments.

- 1.3.5 Never leave the machine running unattended.
- 1.3.6 Never tamper with or disable the function of operating controls.
- 1.3.7 Never use the choke to stop the engine.
- 1.3.8 Never operate the machine in areas where explosions may occur.
- 1.3.9 Read, understand, and follow procedures in the Operator's Manual before attempting to operate the machine.
- 1.3.10 Make sure that all other persons are at a safe distance from the machine. Stop the machine if people step into the working area of the machine.
- 1.3.11 Be sure operator is familiar with proper safety precautions and operation techniques before using machine.
- 1.3.12 Always keep hands, feet, and loose clothing away from moving parts of the machine.
- 1.3.13 Always use common sense and caution when operating the machine.
- 1.3.14 Always be sure the rammer will not tip over, roll, slide, or fall when not being operated.
- 1.3.15 Always turn the engine OFF when the rammer is not being operated.
- 1.3.16 Always guide the rammer in such a way that the operator is not squeezed between the rammer and solid objects. Special care is required when working on uneven ground or when compacting coarse material. Make sure to stand firmly when operating the machine under such conditions.
- 1.3.17 When working near the edges of breaks, pits, slopes, trenches and platforms, always operate the rammer in such a way that there is no danger of it tipping over or falling in.
- 1.3.18 Store the machine properly when it is not being used. The machine should be stored in a clean, dry location out of the reach of children.
- 1.3.19 Close fuel valve on engines equipped with one when machine is not being operated.
- 1.3.20 Always operate machine with all safety devices and guards in place and in working order. Do not modify or defeat safety devices. Do not operate machine if any safety devices or guards are missing or inoperative.
- 1.3.21 Do not transport the machine while it is running.
- 1.3.22 Do not tip the machine for cleaning or for any other reason.

## 1.4 Operator Safety while using Internal Combustion Engines



### WARNING

Internal combustion engines present special hazards during operation and fueling. Failure to follow the warnings and safety standards could result in severe injury or death.

- ▶ Read and follow the warning instructions in the engine owner's manual and the safety guidelines below.



### DANGER

Exhaust gas from the engine contains carbon monoxide, a deadly poison. Exposure to carbon monoxide can kill you in minutes.

- ▶ NEVER operate the machine inside an enclosed area, such as a tunnel, unless adequate ventilation is provided through such items as exhaust fans or hoses.

### Operating safety

When running the engine:

- Keep the area around exhaust pipe free of flammable materials.
- Check the fuel lines and the fuel tank for leaks and cracks before starting the engine. Do not run the machine if fuel leaks are present or the fuel lines are loose.

When running the engine:

- Do not smoke while operating the machine.
- Do not run the engine near sparks or open flames.
- Do not touch the engine or muffler while the engine is running or immediately after it has been turned off.
- Do not operate a machine when its fuel cap is loose or missing.
- Do not start the engine if fuel has spilled or a fuel odor is present. Move the machine away from the spill and wipe the machine dry before starting.

### Refueling safety

When refueling the engine:

- Clean up any spilled fuel immediately.
- Refill the fuel tank in a well-ventilated area.
- Replace the fuel tank cap after refueling.
- Do not smoke.
- Do not refuel a hot or running engine.
- Do not refuel the engine near sparks or open flames.

- Do not refuel if the machine is positioned in a truck fitted with a plastic bed liner. Static electricity can ignite the fuel or fuel vapors.

## 1.5 Service Safety



A poorly maintained machine can become a safety hazard! In order for the machine to operate safely and properly over a long period of time, periodic maintenance and occasional repairs are necessary.

### Personal Protective Equipment (PPE)

Wear the following Personal Protective Equipment (PPE) while servicing or maintaining this machine:

- Close-fitting work clothes that do not hinder movement
- Safety glasses with side shields
- Hearing protection
- Safety-toed footwear

In addition, before servicing or maintaining the machine:

- Tie back long hair.
- Remove all jewelry (including rings).

### Service training

Before servicing or maintaining the machine:

- Read and understand the instructions contained in all manuals delivered with the machine.
- Familiarize yourself with the location and proper use of all controls and safety devices.
- Only trained personnel shall troubleshoot or repair problems occurring with the machine.
- Contact Wacker Neuson Corporation for additional training if necessary.

When servicing or maintaining this machine:

- Do not allow improperly trained people to service or maintain the machine. Personnel servicing or maintaining the machine must be familiar with the associated potential risks and hazards.

- 1.5.1 Do not attempt to clean or service the machine while it is running. Rotating parts can cause severe injury.
- 1.5.2 DO NOT operate the machine without an air cleaner.
- 1.5.3 DO NOT remove air cleaner cover, paper element, or precleaner while engine is running.

- 1.5.4 DO NOT alter engine speeds. Run the engine only at speeds specified in the Technical Data Section.
- 1.5.5 Do not crank a flooded engine with the spark plug removed on gasoline-powered engines. Fuel trapped in the cylinder will squirt out the spark plug opening.
- 1.5.6 Do not test for spark on gasoline-powered engines if the engine is flooded or the smell of gasoline is present. A stray spark could ignite the fumes.
- 1.5.7 Do not use gasoline or other types of fuels or flammable solvents to clean parts, especially in enclosed areas. Fumes from fuels and solvents can become explosive.
- 1.5.8 ALWAYS replace the safety devices and guards after repairs and maintenance.
- 1.5.9 Keep the area around the muffler free of debris such as leaves, paper, cartons, etc. A hot muffler could ignite the debris and start a fire.
- 1.5.10 ALWAYS do periodic maintenance as recommended in the Operator's Manual.
- 1.5.11 ALWAYS clean debris from engine cooling fins.
- 1.5.12 When replacement parts are required for this machine, use only Wacker Neuson replacement parts or those parts equivalent to the original in all types of specifications, such as physical dimensions, type, strength, and material.
- 1.5.13 Disconnect the spark plug on machines equipped with gasoline engines, before servicing, to avoid accidental start-up.
- 1.5.14 Keep the machine clean and labels legible. Replace all missing and hard-to-read labels. Labels provide important operating instructions and warn of dangers and hazards.
- 1.5.15 ALWAYS follow instructions when disconnecting fuel lines. Failure to do so may result in fuel squirting from fuel system.
- 1.5.16 Service and Repair Safety

The service procedures contained in this manual are intended for use by an individual equipped with the proper tools and equipment and familiar with safe shop practices.

Should questions arise during the service or repair of this equipment please contact Wacker Neuson for assistance! Wacker Neuson Corporation maintains a staff of trained service specialists to answer your questions and to provide assistance and training.



DO NOT remove bottom spring cover without first reading disassembly procedures or receiving instruction from someone familiar with its safe removal! The spring cover is under heavy spring pressure and could cause a serious injury if the proper disassembly procedures are not followed.

DO NOT run the engine while it is off the machine without first removing the clutch! Centrifugal force will cause the clutch shoes to separate and fly off the engine crankshaft with considerable force.



## 2 Tools

### 2.1 Recommended Special Tools

See Graphic: *wc\_gr001305rm*

- P/N 0081423 Spring box tool
- P/N 0117972 Clutch puller
- P/N 0153566 Clutch puller (DS 70 only)
- P/N 0116816 Impact bushing puller

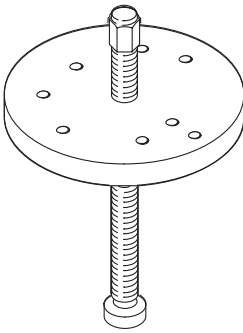

0081423

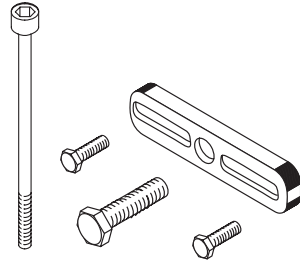

0117972

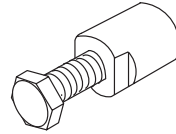

0153566

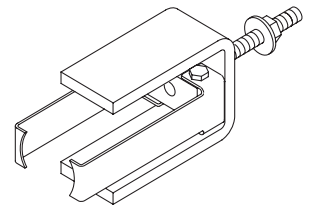

0116816

*wc\_gr001305rm*

## 2.2 Recommended Repair Tools

Hex key or socket: 4 mm, 5 mm, 6 mm, 8 mm  
Ratchet wrench  
Extension  
Sockets: 10 mm, 13 mm, 17 mm, 19 mm (3/4"), 24 mm,  
27 mm (1-1/16"), 32 mm, 38 mm (1-1/2")  
Open-end wrench: 13 mm  
Screwdriver  
Needle-nose pliers  
Large-diameter retaining-ring pliers  
Rubber mallet  
Punch  
Bearing puller  
Slide hammer  
Drift pin  
Impact wrench  
Torque wrench (up to 210 Nm [155 ft.lbs.])  
Loctite 243  
Shell Alvania RL 2 (No. 2) grease  
Hydraulic press  
Two threaded rods M8 x 120 mm and nuts  
Split puller  
Source of compressed air

## 3 Maintenance Schedules

### 3.1 Periodic Maintenance Schedule (BS 50/60/70-2, BS 65)

The table below lists basic machine maintenance. Tasks designated with check marks may be performed by the operator. Tasks designated with square bullet points require special training and equipment.

	Daily before starting	After first 5 hours	Every week or 25 hours	Every month or 100 hours	Every 3 months or 300 hours	Every Year
Check fuel level.	✓					
Check air filter indicator. Replace as needed.	✓					
Check ramming system oil level in sightglass.	✓					
Check fuel line and fittings for cracks or leaks. Replace as needed.	■					
Tighten ramming shoe hardware.		■	■			
Check engine cylinder screws.		■	■			
Check external hardware.		✓	✓			
Clean engine cooling fins.			✓			
Clean and check spark plug gap.			■			
Replace spark plug.				■		
Clean recoil starter.					✓	
Change ramming system oil.*					■	
Clean engine muffler and exhaust port.					■	
Inspect lifting cable for wear, damage, or abuse.					✓	
Inspect fuel filter.						✓

\* Change ramming system oil after first 50 hours of operation.

**Note:** If engine performance is poor, check, clean, and replace air filter elements as needed.

3.2 Periodic Maintenance Schedule (BS 500/600/700/650)

The table below lists basic machine maintenance. Tasks designated with check marks may be performed by the operator. Tasks designated with square bullet points require special training and equipment.

	Daily before starting	After first 5 hours	Every week or 25 hours	Every month or 100 hours	Every 3 months or 300 hours	Every Year
Check fuel level. Check engine oil level.	✓					
Inspect air filter. Replace as needed.	✓					
Check oil level in sightglass.	✓					
Check fuel line and fittings for cracks or leaks. Replace as needed.	■					
Tighten ramming shoe hardware.		■	■			
Check external hardware.		✓	✓			
Clean engine cooling fins.			✓			
Clean and check spark plug gap.			■			
Change engine oil.				■		
Replace spark plug.				■		
Clean recoil starter.					✓	
Change ramming system oil.*					■	
Inspect lifting cable on rammer for wear, damage, or abuse.					✓	
Inspect fuel filter.						✓
* Change ramming system oil after first 50 hours of operation. <b>Note:</b> If engine performance is poor, check, clean, and replace air filter elements as needed.						

## 3.3 Periodic Maintenance Schedule (BS 50/60/70-2i)

The table below lists basic machine maintenance. Tasks designated with check marks may be performed by the operator. Tasks designated with square bullet points require special training and equipment.

	Daily before starting	After first 5 hours	Every week or 25 hours	Every month or 100 hours	Every 3 months or 300 hours	Every Year
Check fuel level.	✓					
Check engine oil level.	✓					
Check air filter indicator. Replace as needed.	✓					
Check ramming system oil level in sightglass.	✓					
Check fuel line and fittings for cracks or leaks. Replace as needed.	■					
Tighten ramming shoe hardware.		■	■			
Check engine cylinder screws.		■	■			
Check external hardware.		✓	✓			
Clean engine cooling fins.			✓			
Clean and check spark plug gap.			■			
Replace spark plug.				■		
Clean recoil starter.					✓	
Change ramming system oil.*					■	
Clean engine muffler and exhaust port.					■	
Inspect lifting cable for wear, damage, or abuse.					■	
Inspect fuel filter.						✓
<p>* Change ramming system oil after first 50 hours of operation.  <b>Note:</b> If engine performance is poor, check, clean, and replace air filter elements as needed.</p>						

3.4 Periodic Maintenance Schedule (BS 500/600/700-oi)

The table below lists basic machine maintenance. Tasks designated with check marks may be performed by the operator. Tasks designated with square bullet points require special training and equipment.

	Daily before starting	After first 5 hours	Every week or 25 hours	Every month or 100 hours	Every 3 months or 300 hours	Every Year
Check fuel level.	▪					
Inspect air filter. Replace as needed.	▪					
Check engine oil level.	▪					
Check ramming system oil level in sightglass.	▪					
Check fuel line and fittings for cracks or leaks.	▪					
Tighten ramming shoe hardware.		▪	▪			
Check engine cylinder screws.		▪	▪			
Check external hardware.		▪	▪			
Clean engine cooling fins.			▪			
Clean and check spark plug gap.			▪			
Replace spark plug.				▪		
Clean recoil starter.					▪	
Change ramming system oil.*					▪	
Clean engine muffler and exhaust port.					▪	
Inspect crane lifting cable for wear, damage, or abuse.					▪	▪
Inspect fuel filter. Inspect oil filter.						▪
* Change ramming system oil after first 50 hours of operation. <b>Note:</b> If engine performance is poor, check, clean, and replace air filter elements as needed.						

## 3.5 Periodic Maintenance Schedule (DS 70)

	Daily before starting	After first 5 hours	Every week or 25 hours	Every month or 100 hours	Every 3 months or 300 hours	Every 5 months or 500 hours
Check fuel level.	✓					
Check engine oil level.	✓					
Check air filter indicator. Replace as needed.	✓					
Check rammer oil level in sightglass.	✓					
Check fuel line, cap and fittings for cracks or leaks. Replace as needed.	✓					
Check bellows for damage and fit.	✓					
Tighten ramming shoe hardware.		■	■			
Check external hardware.		✓	✓			
Clean engine cooling fins.			✓			
Change engine oil.*				■		
Clean engine oil filter.*					■	
Clean recoil starter.					■	
Change ramming system oil.*					■	
Inspect lifting cable for wear, damage, or abuse.					■	
Check and adjust valve clearance. **			■			■
Replace engine oil filter.						■
Check fuel filter, clean or replace.						■

\* Perform initially after first 50 hours of operation.

**Note:** If engine performance is poor, check, clean, and replace air filter elements as needed.

\*\* Perform initially after first 25 hours of operation.

3.6 Periodic Maintenance Schedule (DS 720)

The table below lists basic machine maintenance. Tasks designated with check marks may be performed by the operator. Tasks designated with square bullet points require special training and equipment.

	Daily before starting	After first 5 hours	Every week or 25 hours	Every month or 100 hours	Every 3 months or 300 hours	Every 5 months or 500 hours
Check fuel level.	■					
Check engine oil level.	■					
Check rammer oil level in sightglass.	■					
Check fuel line, cap and fittings for cracks or leaks.	■					
Check bellows for damage and fit.	■					
Tighten ramming shoe hardware.		■	■			
Check external hardware.		■	■			
Clean engine cooling fins.		■	■			
Change engine oil.*			■			
Clean engine oil filter.*				■		
Clean recoil starter.					■	
Change ramming system oil.*					■	
Inspect crane lifting cable for wear, damage, or abuse.					■	
Check and adjust valve clearance.**					■	
Replace engine oil filter.						■
Check fuel filter, clean or replace.						■

\* Perform initially after first 50 hours of operation.

\*\* Perform initially after first 25 hours of operation.

**Note:** If engine performance is poor, check, clean, and replace air filter elements as needed.



4 Engine and Upper Machine Components

4.1 Removing the Silencing Cover

See Graphic: *wc\_gr007457*

**Recommended Tools**

Ratchet Wrench

Torque Wrench

Hex Key or Hex Socket: 5 mm

Loctite 243 (Blue)

Remove the four socket head cap screws **(b)** that hold the silencing cover **(a)** to the guide handle **(c)**. When reinstalling the silencing cover, apply Loctite 243 and torque the screws to 9.4 Nm (6.9 ft.lbs.).

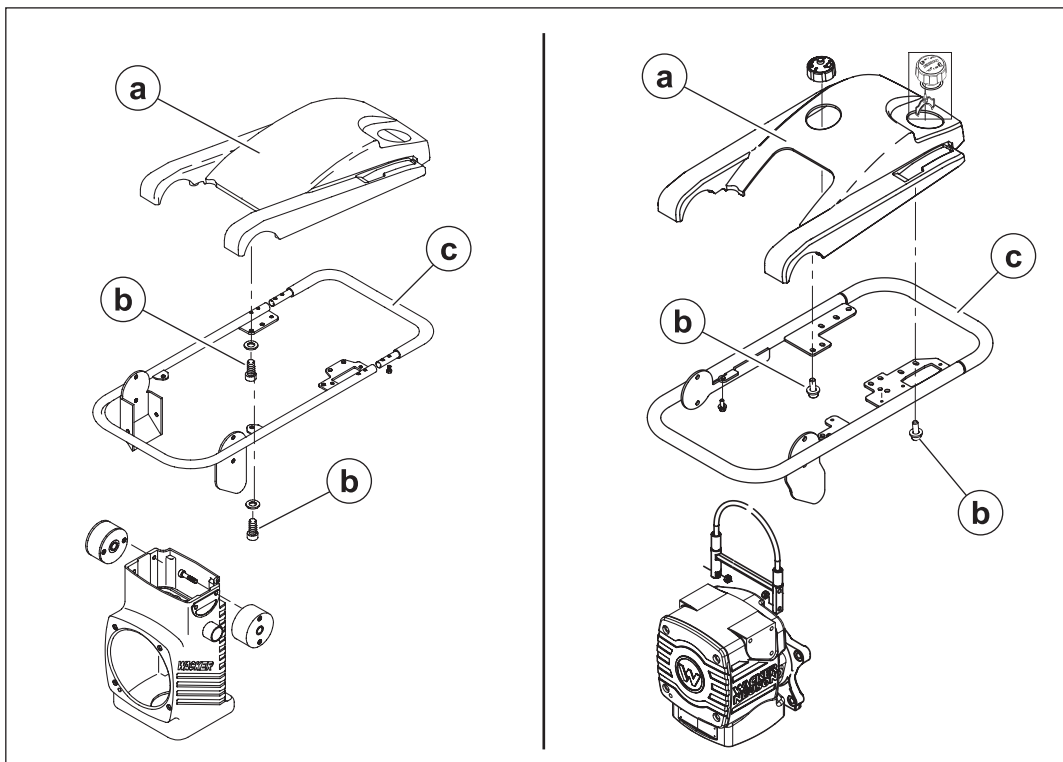

wc\_gr007457

## 4.2 Replacing the Throttle Control (2010 and later 2-stroke models)

### Requirements

- Machine shut down and cool
- Torque wrench

### Removal

Perform the procedure below to remove the throttle control.

4.2.1 Remove the silencing cover. See topic *Removing the Silencing Cover*.

4.2.2 Remove the carburetor guard (a).

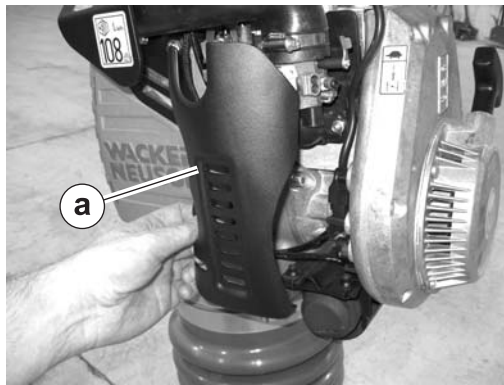

wc\_gr007416

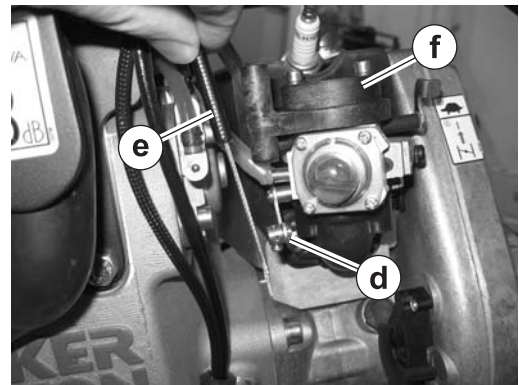

wc\_gr007418

4.2.3 Loosen the swivel (d) and slide the throttle cable and casing (e) from the carburetor adapter (f).

4.2.4 Remove the bolt (h) and hardware (b).

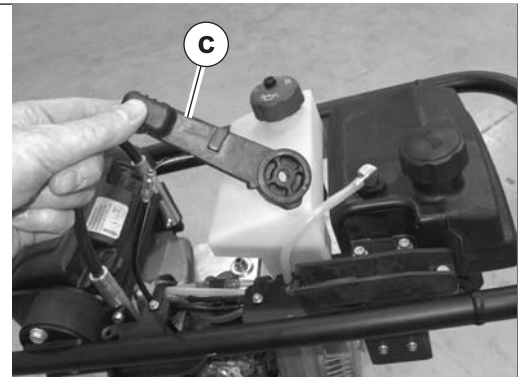
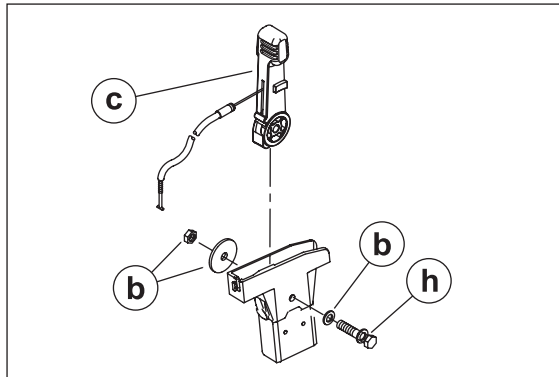

wc\_gr007459

4.2.5 Remove the throttle control (c) from the machine.

### Result

The throttle control has now been removed.

## Installation

Perform the procedure below to install the throttle control.

- 4.2.1 Connect the throttle control (c) to the machine with bolt (h) and hardware (b). Adjust the nut on the throttle control lever so that the lever moves freely but still holds its position while the rammer is operating. The recommended torque value is 2.9 Nm (2.1 ft.lbs.).

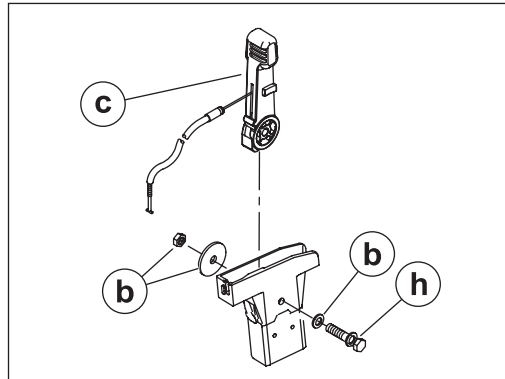

wc\_gr007460

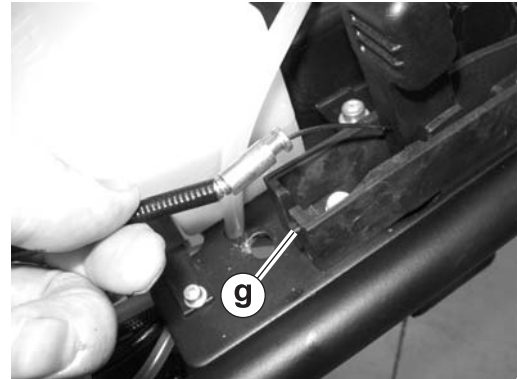

wc\_gr007461

- 4.2.2 Connect the throttle cable to the machine at point (g).
- 4.2.3 Connect the throttle cable to the carburetor. To do so:
- Place the throttle control (c) in the full throttle position with a 0.76 mm (0.030 in.) feeler gauge between the throttle control and the machine.
  - Rotate the throttle lever (x) so that it is tight against the carburetor adapter (f).
  - Thread the throttle cable (e) through the carburetor adapter and through the swivel (d). Pull the throttle cable taught, then tighten the swivel screw.
  - Release the throttle lever.

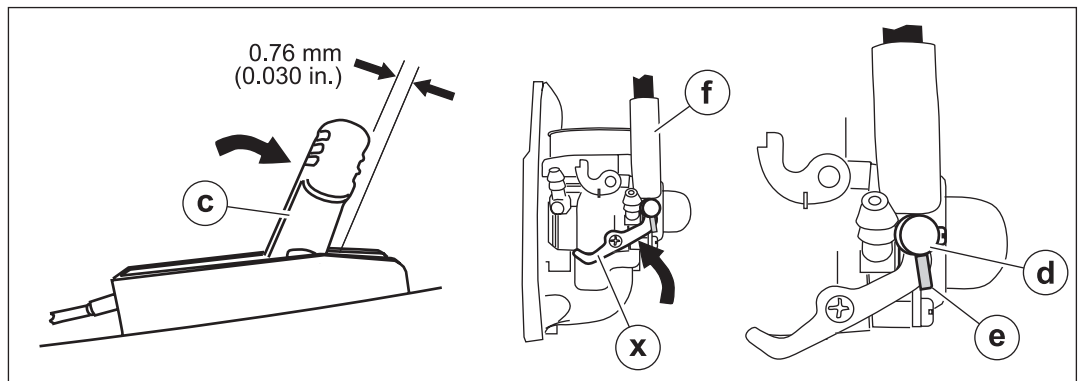

wc\_gr007572

- 4.2.4 Install the carburetor guard (a). Torque the screws to 23 Nm (16 ft.lbs.)

## Result

The replacement procedure is now complete.

### 4.3 Replacing the Throttle Control (2010 4-stroke models)

#### Requirements

- Machine shut down and cool
- Torque wrench

#### Removal

Perform the procedure below to remove the throttle control.

4.3.1 Remove the silencing cover. See topic *Removing the Silencing Cover*.

4.3.2 Disconnect the throttle cable at the swivel (a) and the clamp (b).

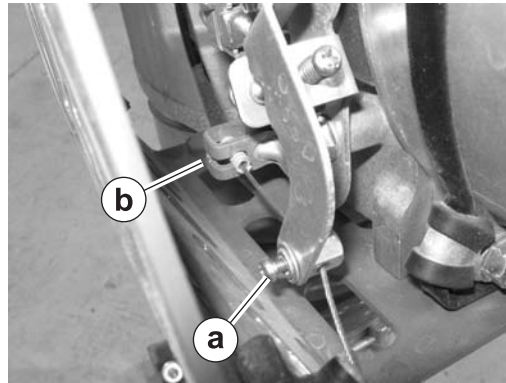

wc\_gr007474

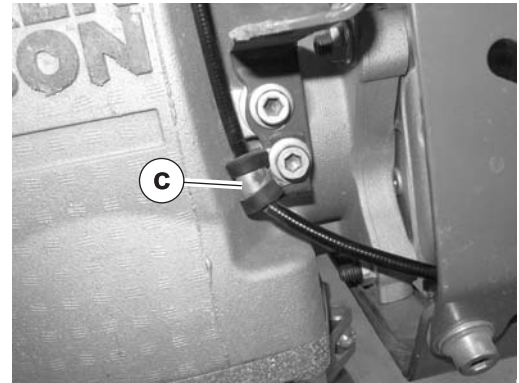

wc\_gr007475

4.3.3 Remove the clamp (c).

4.3.4 Clip the wire ties (d).

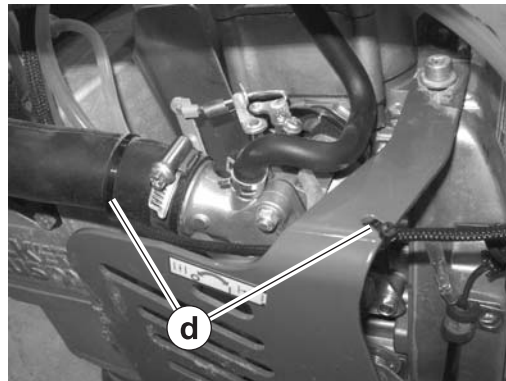

wc\_gr007476

*This procedure continues on the next page.*

*Continued from the previous page.*

- 4.3.5 Remove the bolt (h) and hardware (b).

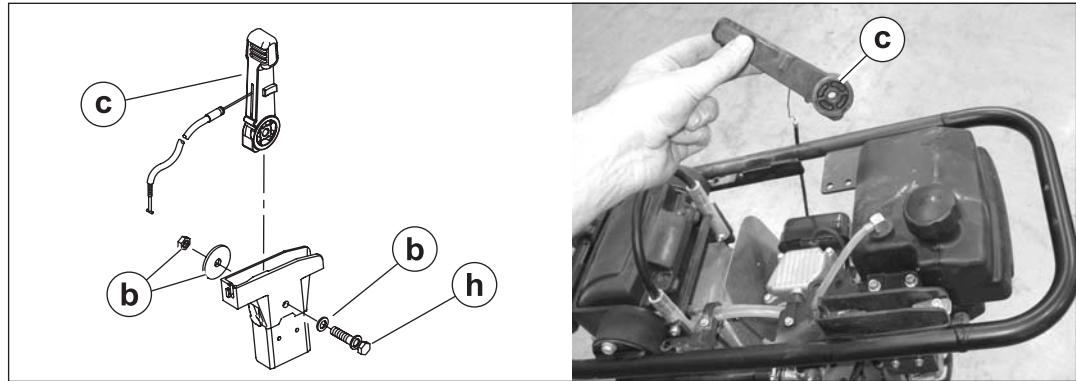

wc\_gr007477

- 4.3.6 Remove the throttle lever (c) from the machine.

## Result

The removal procedure is now complete.

## Installation

Perform the procedure below to install the throttle control.

- 4.3.1 Connect the throttle lever (c) to the machine with bolt (h) and hardware (b). Adjust the nut on the throttle control lever so that the lever moves freely but still holds its position while the rammer is operating. The recommended torque value is 2.9 Nm (2.1 ft.lbs.).

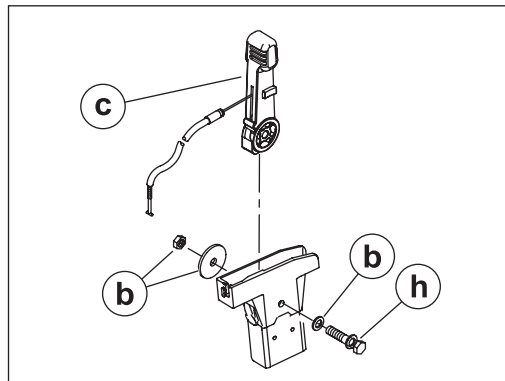

wc\_gr007460

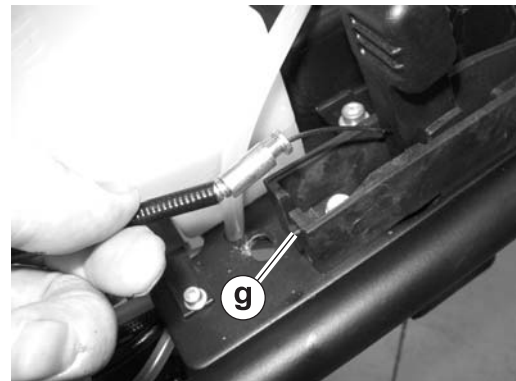

wc\_gr007461

- 4.3.2 Connect the throttle cable to the machine at point (g).

*This procedure continues on the next page.*

*Continued from the previous page.*

- 4.3.3 Support the throttle cable with new wire ties (**d**).

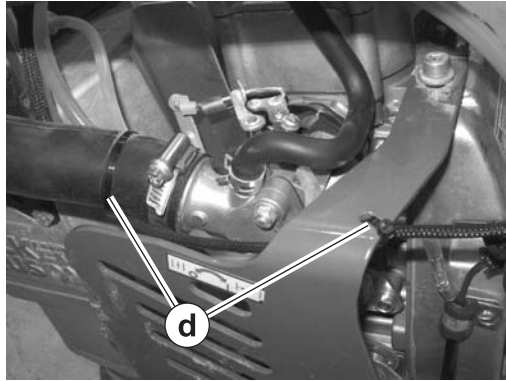

wc\_gr007476

- 4.3.4 Install the clamp (**c**).

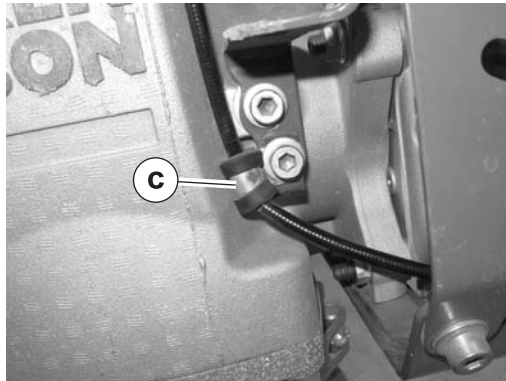

wc\_gr007475

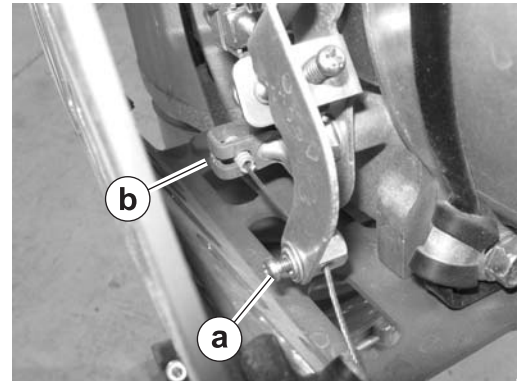

wc\_gr007474

- 4.3.5 Connect the throttle cable at the swivel (**a**) and the clamp (**b**).
- 4.3.6 Reinstall the silencing cover.

## Result

The replacement procedure is now complete.

## 4.4 Throttle Control (pre-2010 models)

See Graphic: wc\_gr003876

4.4.1 Adjust the nut **(a)** on the throttle control lever **(b)** so that the lever moves freely but still holds its position while the rammer is operating. The recommended torque value is 2.9 Nm (2.1 ft.lbs.).

To adjust the throttle cable:

4.4.2 Place the throttle lever in the STOP position **(c)**.

4.4.3 Loosen the clamp screws **(d)**.

4.4.4 Slide the throttle cable **(e)** through the clamp until there is slack **(f)** in the throttle cable and the stop lever activates the stop button **(g)**.

4.4.5 Tighten the clamp screws.

4.4.6 Place the throttle control in the IDLE position **(h)**.

4.4.7 Check that the stop button is not activated. There should be a gap **(i)** between the stop lever and the stop button.

4.4.8 Adjust the cable at the clamp as necessary so that the engine stops when the throttle control is in the STOP position and idles when the throttle control is in the IDLE position.

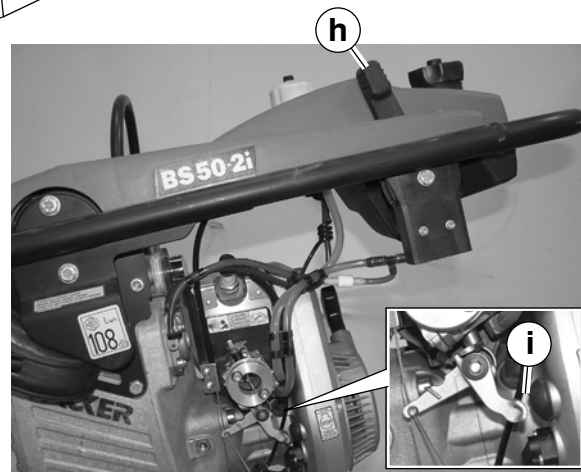
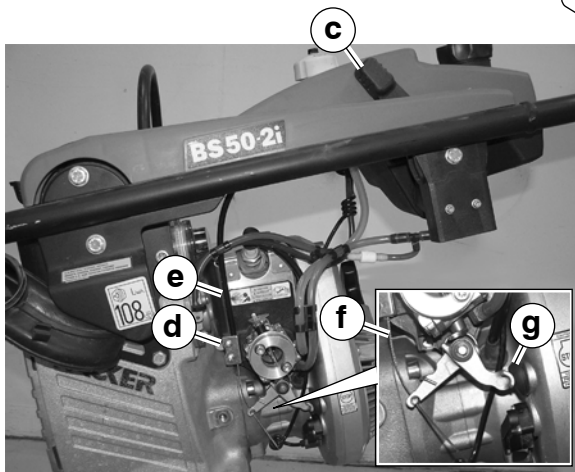
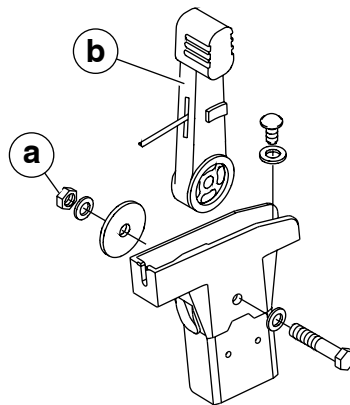

wc\_gr003876

## 4.5 Replacing the Stop Switch (2010 and later 2-stroke models)

### Requirements

- Machine shut down and cool
- Torque wrench

### Removal

Perform the procedure below to remove the stop switch.

- 4.5.1 Remove the silencing cover. See topic *Replacing the Silencing Cover*.
- 4.5.2 Remove the throttle control. See topic *Replacing the Throttle Control*.
- 4.5.3 Remove the two screws **(a)** that hold the fuel valve to the throttle control bracket. Allow the fuel valve **(b)** to hang by the fuel hoses.

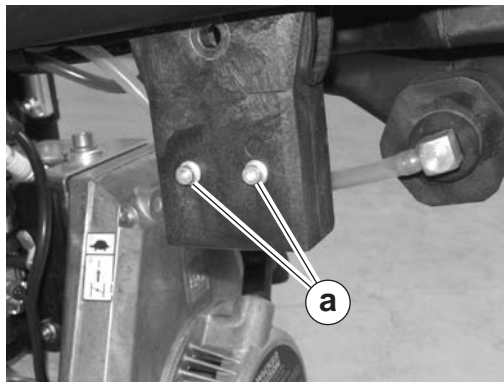

wc\_gr007463

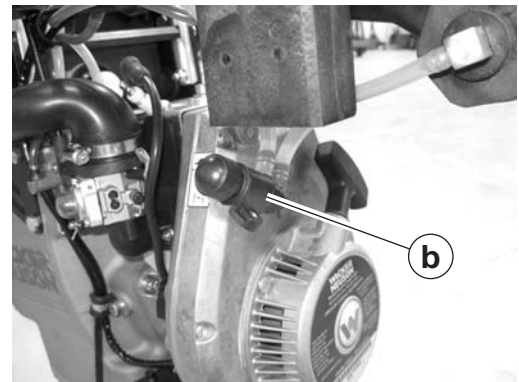

wc\_gr007462

- 4.5.4 Disconnect the stop switch wiring **(c)** from the engine.

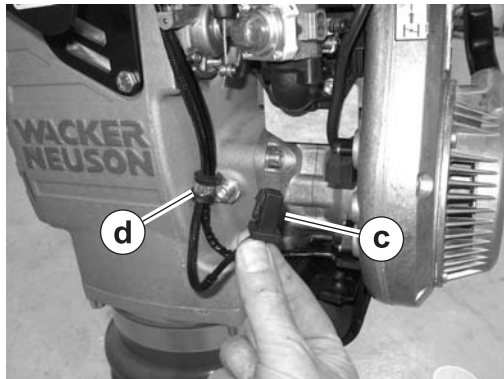

wc\_gr007464

- 4.5.5 Remove the clamp **(d)**.

*This procedure continues on the next page.*



*Continued from the previous page.*

- 4.5.6 Remove the screws **(g)** that hold the throttle control bracket to the machine and pull the throttle control bracket **(e)** (with stop switch) from the machine.

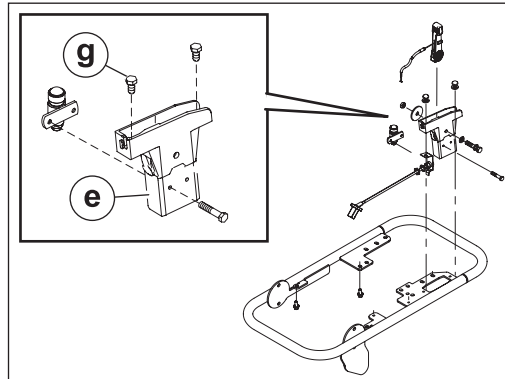

wc\_gr007467

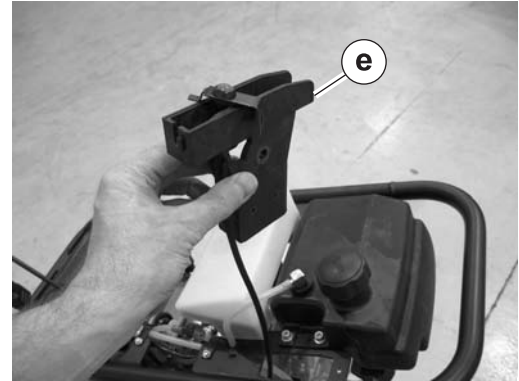

wc\_gr007465

- 4.5.7 Pull the stop switch **(f)** and wiring from the throttle control bracket.

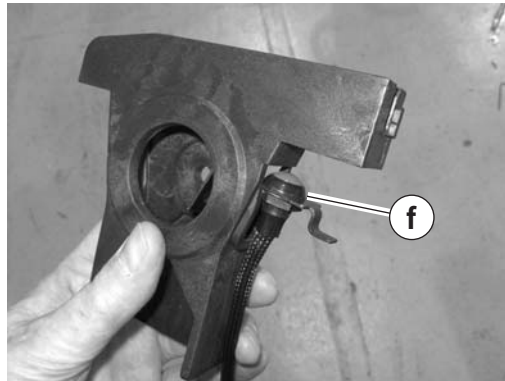

wc\_gr007466

## Result

The removal procedure is now complete.

## Installation

Perform the procedure below to install the stop switch.

- 4.5.1 Slide the stop switch **(f)** into the throttle control bracket **(e)** and thread the wiring through the throttle control bracket.

*This procedure continues on the next page.*

*Continued from the previous page.*

- 4.5.2 Install the throttle control bracket and the stop switch (f) with screws (g). Torque the screws to 10 Nm (7 ft.lbs.).

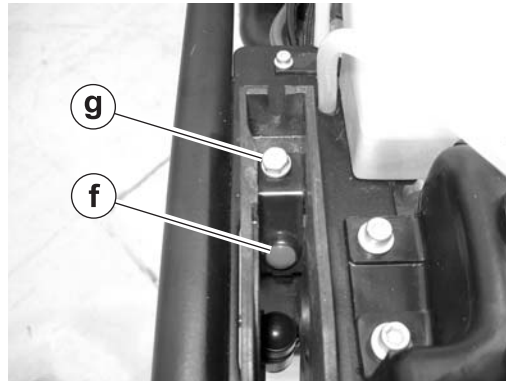

wc\_gr007468

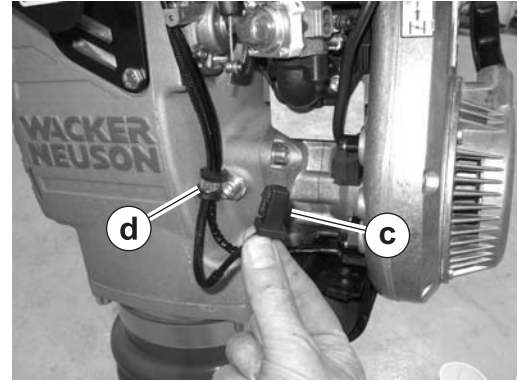

wc\_gr007464

- 4.5.3 Reconnect the stop switch wiring (c) to the engine.
- 4.5.4 Reinstall the clamp (d).
- 4.5.5 Reinstall the throttle control.
- 4.5.6 Reinstall the silencing cover.

## Result

The replacement procedure is now complete.

## 4.6 Replacing the Stop Switch (2010 and later 4-stroke models)

### Requirements

- Machine shut down and cool
- Torque wrench

### Removal

Perform the procedure below to remove the stop switch.

4.6.1 Remove the silencing cover. See topic *Replacing the Silencing Cover*.

4.6.2 Remove the throttle control. See topic *Replacing the Throttle Control*.

4.6.3 Disconnect the wiring (**c** and **d**) from the engine.

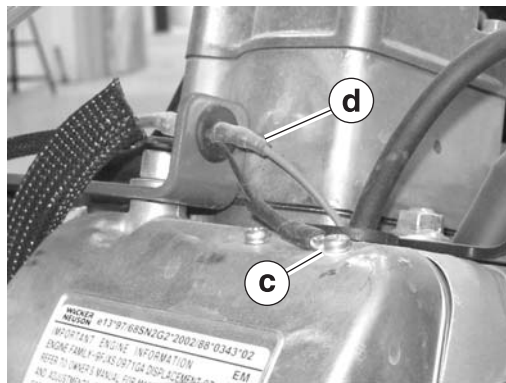

wc\_gr007485

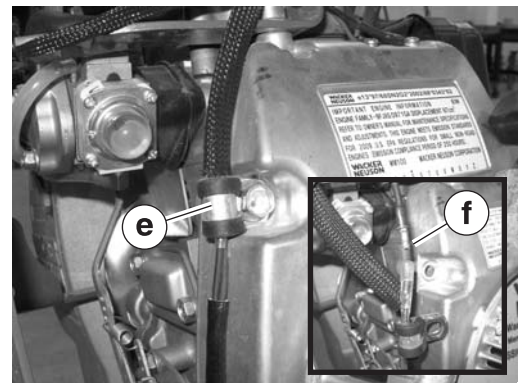

wc\_gr007486

4.6.4 Remove the clamp (**e**). Disconnect the wiring connector (**f**).

4.6.5 Remove the screw (**g**) that holds the stop switch and remove the stop switch (**h**) from the throttle control bracket.

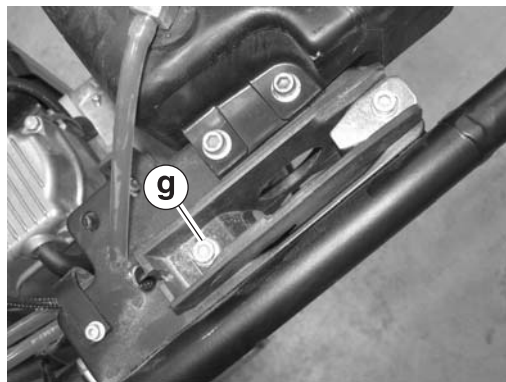

wc\_gr007487

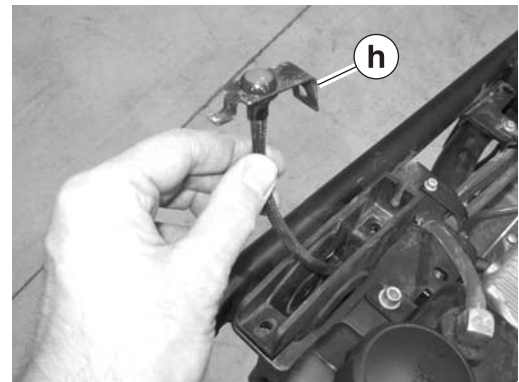

wc\_gr007488

### Result

The removal procedure is now complete.

*This procedure continues on the next page.*

Continued from the previous page.

## Installation

Perform the procedure below to install the stop switch.

- 4.6.1 Slide the stop switch (**h**) into the throttle control bracket and thread the wiring through the throttle control bracket.

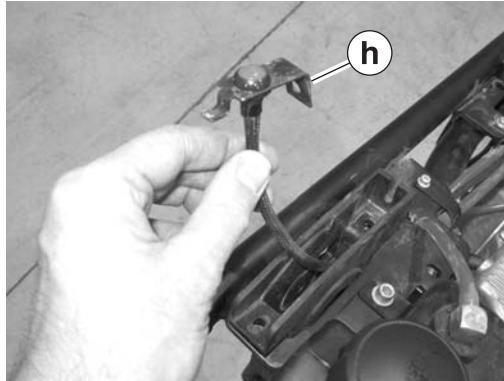

wc\_gr007488

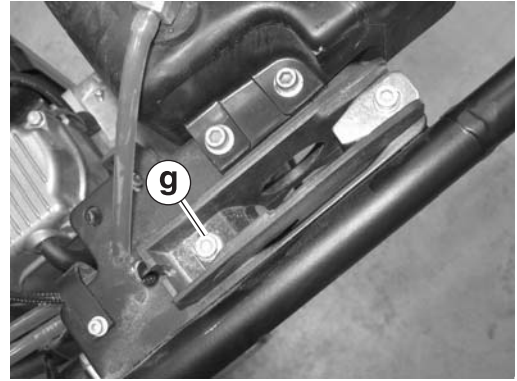

wc\_gr007487

- 4.6.2 Install the stop switch to the machine with screw (**g**). Torque the screw to 9 Nm (6 ft.lbs.).
- 4.6.3 Reconnect the wiring connector (**f**). Apply Loctite 243® to the screw holding the clamp (**e**) and reinstall the clamp (**e**). Torque the screw to 25 Nm (18 ft.lbs.).

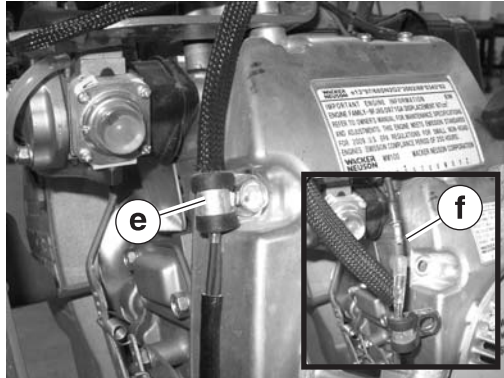

wc\_gr007486

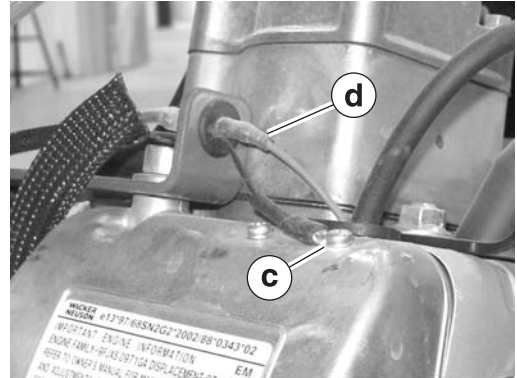

wc\_gr007485

- 4.6.4 Reconnect the wiring (**c** and **d**) to the engine.

## Result

The procedure to replace the stop switch is now complete.

## 4.7 Replacing the Guide Handle (2010 and later 2-stroke models)

### Requirements

- Machine shut down and cool
- Loctite® 243

### Removal

Perform the procedure below to remove the guide handle.

- 4.7.1 Remove the silencing cover. See topic *Replacing the Silencing Cover*.
- 4.7.2 Remove the throttle control. See topic *Replacing the Throttle Control*.
- 4.7.3 Remove the throttle control bracket. See topic *Replacing the Stop Switch*.
- 4.7.4 Drain the fuel tank (optional).
- 4.7.5 Remove the screws (a) that hold the fuel tank to the guide handle.

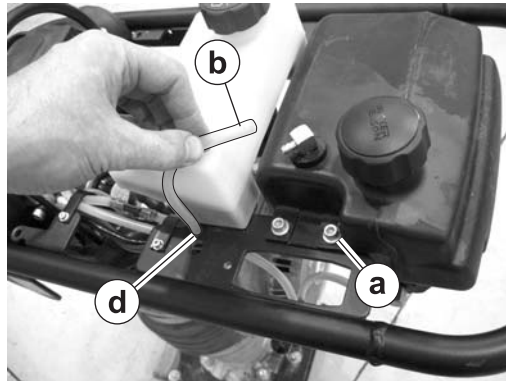

wc\_gr007469

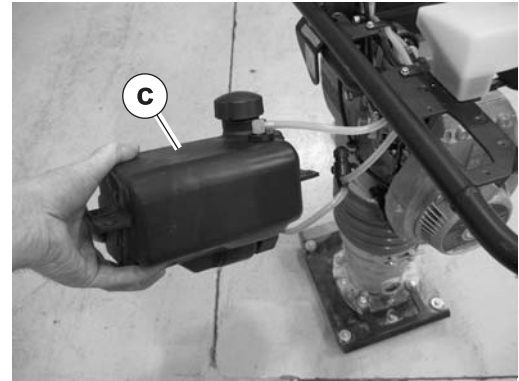

wc\_gr007470

- 4.7.6 Disconnect the upper fuel line (b) from the tank. Thread the fuel line through the hole in the guide handle (d), then reconnect it to the fuel tank (c). Place the fuel tank on top of engine.
- 4.7.7 On machines with oil tanks, remove the screws (e) that hold the oil tank to the guide handle and place the oil tank on top of the engine.

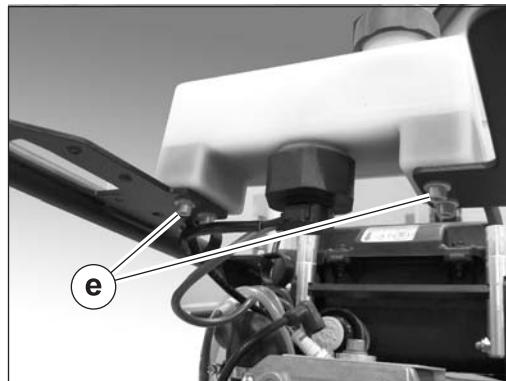

wc\_gr007471

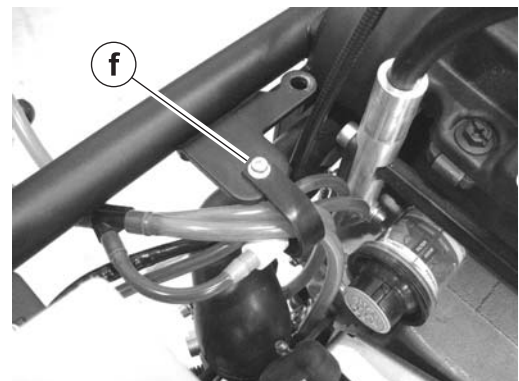

wc\_gr007472

- 4.7.8 Remove the oil hose and the fuel hose from the clips (f) on the handles.  
*This procedure continues on the next page.*

*Continued from the previous page.*

- 4.7.9 Remove the screws that hold the guide handle (g) to the shock mounts and remove the guide handle from the machine.

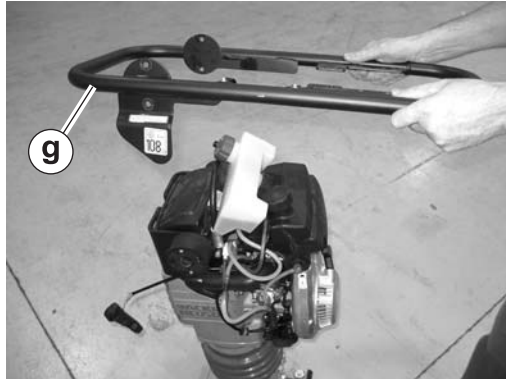

wc\_gr007473

## Result

The removal procedure is now complete.

## Installation

Perform the procedure below to install the guide handle.

- 4.7.1 Install the guide handle to the shock mounts. Use Loctite® 243 on the screws and torque the screws to 24 Nm (18 ft.lbs.).
- 4.7.2 Feed the hoses through the clips (f).

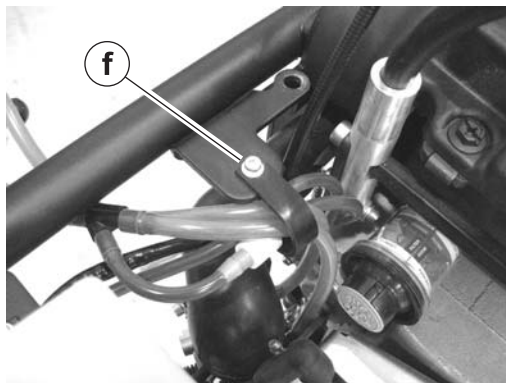

wc\_gr007472

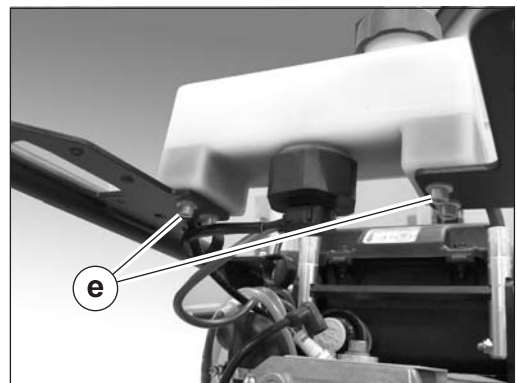

wc\_gr007471

- 4.7.3 Install the oil tank to the guide handle using the screws (e). Torque the screws to 9 Nm (6 ft.lbs.).

*This procedure continues on the next page.*

*Continued from the previous page.*

- 4.7.4 Thread the upper fuel line **(b)** through the hole **(d)** in the guide handle and connect it to the fuel tank.

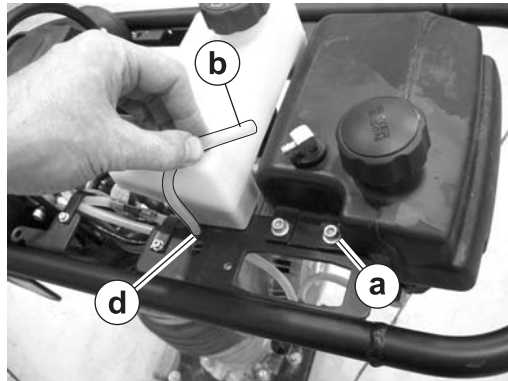

wc\_gr007469

- 4.7.5 Install the fuel tank with screws **(a)**. Torque the screws to 9 Nm (6 ft.lbs.).
- 4.7.6 Install the throttle control bracket. See topic *Replacing the Stop Switch*.
- 4.7.7 Install the throttle control. See topic *Replacing the Throttle Control*.
- 4.7.8 Install the silencing cover. See topic *Replacing the Silencing Cover*.

## Result

The replacement procedure is now complete.

## 4.8 Replacing the Guide Handle (2010 and later 4-stroke models)

### Requirements

- Machine shut down and cool
- Torque wrench
- Loctite® 243

### Removal

Perform the procedure below to remove the guide handle.

- 4.8.1 Remove the silencing cover. See topic *Replacing the Silencing Cover*.
- 4.8.2 Remove the throttle control. See topic *Replacing the Throttle Control*.
- 4.8.3 Remove the stop switch. See topic *Replacing the Stop Switch*.
- 4.8.4 Drain the fuel tank (optional).
- 4.8.5 Remove the screws (a) that hold the fuel valve. Allow the fuel valve (b) to hang freely.

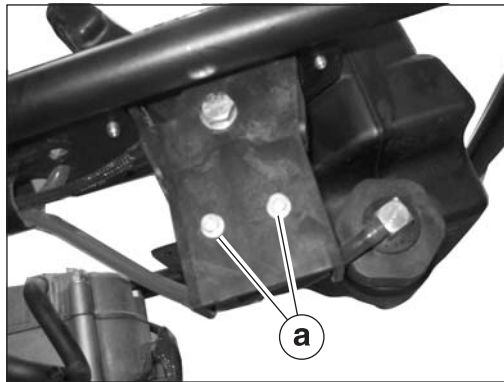

wc\_gr007484

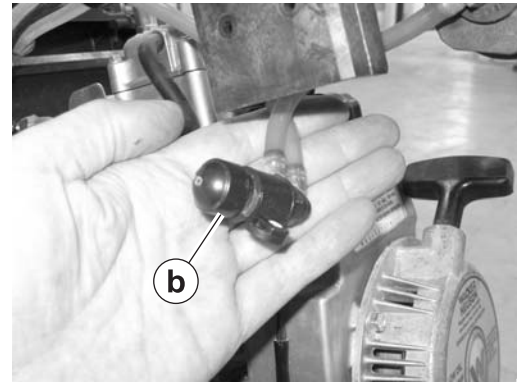

wc\_gr007478

- 4.8.6 Remove the screw that holds the throttle stop (i) and remove the throttle stop.



wc\_gr007498

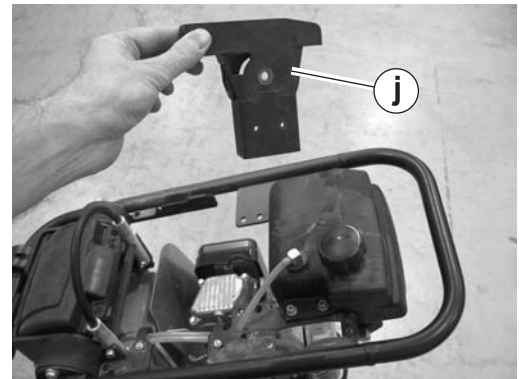

wc\_gr007499

- 4.8.7 Remove the throttle control bracket (j).

*This procedure continues on the next page.*



*Continued from the previous page.*

- 4.8.8 Remove the screws (**e**) that hold the fuel tank to the guide handle.

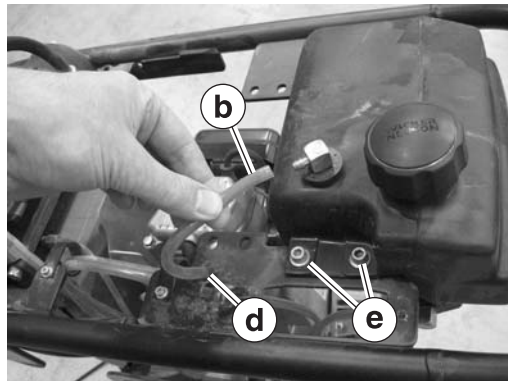

wc\_gr007494



wc\_gr007496

- 4.8.9 Disconnect the upper fuel line (**b**) from the tank. Thread the fuel line through the hole in the guide handle (**d**), then reconnect it to the fuel tank. Place the fuel tank (**c**) on top of engine.

- 4.8.10 Remove the screws that hold the guide handle (**g**) to the shock mounts and remove the guide handle from the machine.



wc\_gr007496

## Result

The removal procedure is now complete.

## Installation

Perform the procedure below to install the guide handle.

- 4.8.1 Install the guide handle **(g)** to the shock mounts. Use Loctite® 243 on the screws and torque the screws to 24 Nm (18 ft.lbs.).



wc\_gr007496

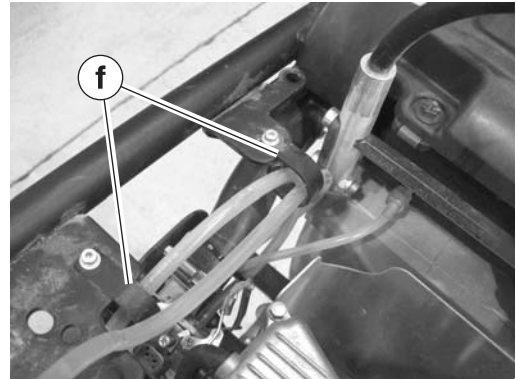

wc\_gr007497

- 4.8.2 Feed the hoses through the clips **(f)**.
- 4.8.3 Install the fuel tank to the guide handle with screws **(e)**. Torque the screws to 9 Nm (6 ft.lbs.).

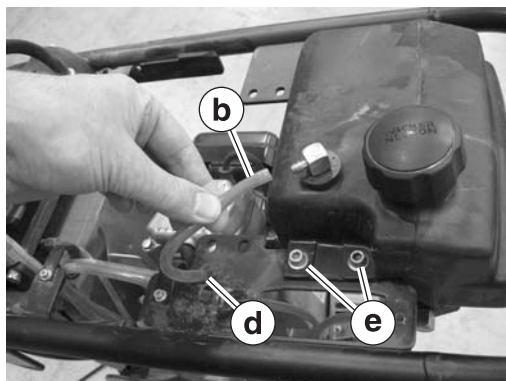

wc\_gr007494

- 4.8.4 Thread the upper fuel line **(b)** through the hole in the guide handle **(d)**, then reconnect it to the fuel tank.

*This procedure continues on the next page.*

*Continued from the previous page.*

- 4.8.5 Install the throttle stop and the throttle control bracket with screw (i). Torque the screw to 9 Nm (6 ft.lbs.).



wc\_gr007498

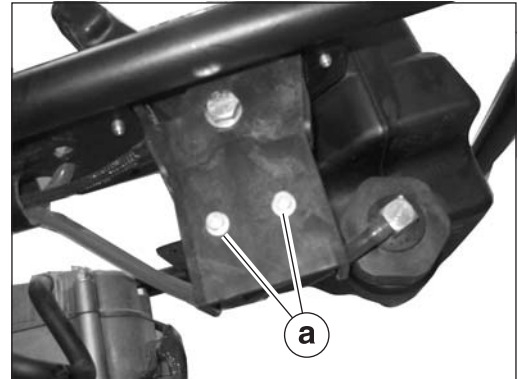

wc\_gr007484

- 4.8.6 Install the fuel valve with screws (a). Torque the screws to 3 Nm (2 ft.lbs.).
- 4.8.7 Install the stop switch. See topic *Replacing the Stop Switch*.
- 4.8.8 Install the throttle control. See topic *Replacing the Throttle Control*.
- 4.8.9 Install the silencing cover. See topic *Replacing the Silencing Cover*.

## Result

The replacement procedure is now complete.

## 4.9 Replacing the Guide Handle (pre-2010 models)

See Graphic: wc\_gr003704

**Recommended Tools**

Ratchet Wrench

Socket: 10 mm

Screwdriver

Pliers

Loctite 243 (Blue)

- 4.9.1 Close the fuel valve.
- 4.9.2 Disconnect the fuel line.
- 4.9.3 Loosen the throttle cable holder.
- 4.9.4 Disconnect the throttle cable from the throttle cam lever.
- 4.9.5 Remove the silencing cover.
- 4.9.6 Remove the four hex head cap screws (**d**) that hold the guide handle to the shock mounts (**e**). When reinstalling the guide handle, apply Loctite 243 and torque the screws to 23 Nm (17 ft.lbs.).
- 4.9.7 Move the guide handle down and away from the shock mounts.
- 4.9.8 Lift the guide handle from the rammer.

**Note:** To inspect or change the shock mounts, it is not necessary to disconnect the fuel line or the throttle cable.

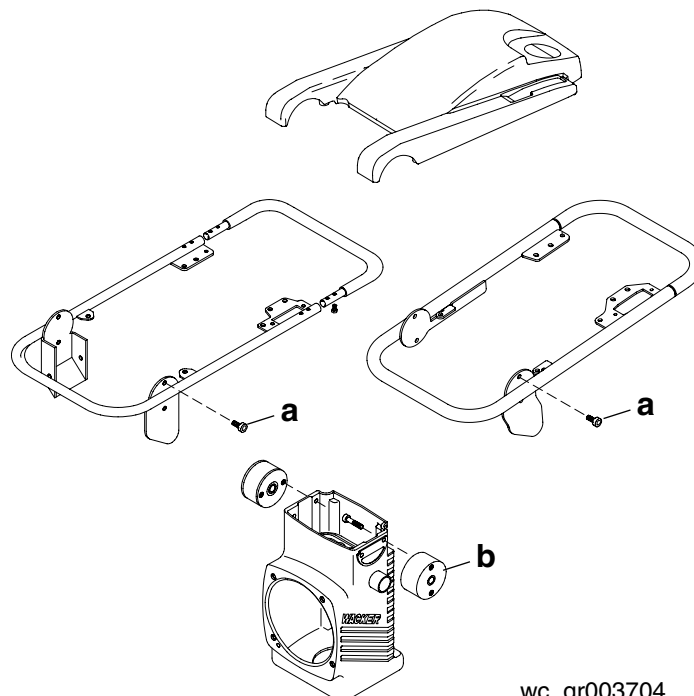

wc\_gr003704

## 4.10 Shock Mounts

See Graphic: wc\_gr003705

### Recommended Tools

Ratchet Wrench  
Torque Wrench  
Loctite 243 (blue)

- 4.10.1 Remove the silencing cover, the air cleaner, and the guide handle.
- 4.10.2 Inspect the shock mounts **(a)** and make sure that they are securely mounted to the crankcase. Replace the shock mounts if they are torn or damaged.
- 4.10.3 Remove the four socket head cap screws **(b)** that hold the shock mounts to the crankcase. On Rammers with guards, remove the guards **(c)** from the crankcase. Then, remove the screws that hold the shock mounts to the guard. When reinstalling the shock mounts, apply Loctite 243 or an equivalent to the screws and torque them to 34 Nm (25 ft.lbs.).

**Note:** Replace the shock mounts as a set. Check the shock mount screws after the first five hours of operation and tighten them if necessary.

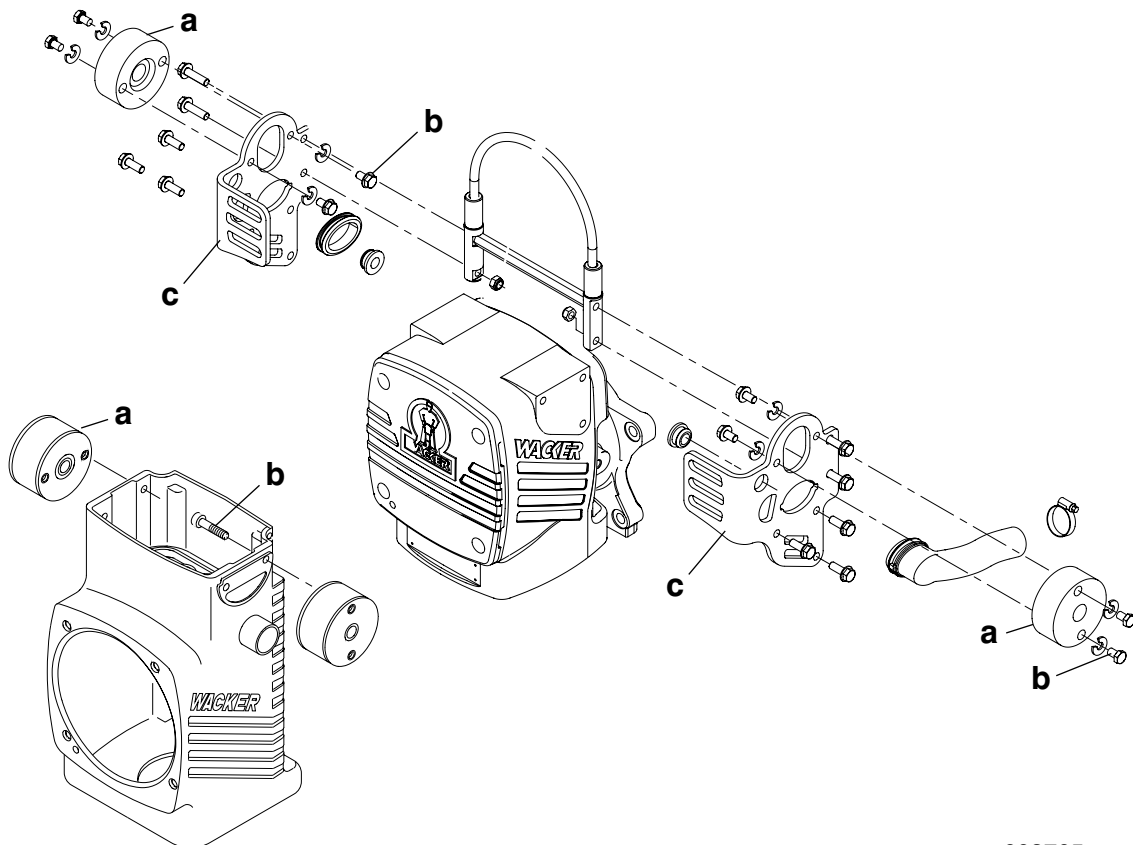

wc\_gr003705

## 4.11 Tillotson Carburetor (BS 500/600/700/650 only)

See Graphic: *wc\_gr001308rm*

### Recommended Tools

Ratchet Wrench  
Torque Wrench  
Hex Key or Hex Socket: 4 mm, 6 mm  
Screwdriver  
Loctite 243 (blue)

The Tillotson carburetor uses a fixed low and high speed fuel jet. The only adjustment is to set the engine idle speed.

Refer to section *Technical Data* for the correct idle and operating rpm. For best accuracy, use a tachometer when making carburetor adjustments.

**NOTICE:** The engine is lubricated by the fuel mixture; running the engine too lean could cause it to overheat.

### High Altitude Operation

The WM 80 engine used in the rammers is designed to operate most efficiently at normal altitudes (1524 meters) (up to 5000 ft.). At high altitudes (1524 meters) (above 5000 ft.) minor modifications to the carburetor can be made to improve its performance. All modifications must be performed by an authorized WACKER dealer. Contact WACKER Corporation for more information.

High altitude operations involve modifications to the engine air/fuel mixture. At normal altitudes, these modifications can be damaging to the engine components. When returning the rammer to normal altitude operation, remember to reset the carburetor to its standard specifications.

### Setting Idle Speed Adjustment

- 4.11.1 Start the engine and allow it to warm up to operating temperature.
- 4.11.2 Set the engine idle speed with the engine running at idle and the choke **(a)** fully open. Adjust the idle speed screw **(b)** in or out to obtain the correct idle speed.

**NOTICE: DO NOT** turn the adjusting screw in too tightly or you may damage the carburetor.

### Removing the Carburetor

- 4.11.3 Remove the three socket head cap screws holding the carburetor guard to the engine. When reinstalling the carburetor guard, apply Loctite 243 and torque the screws to 23 Nm (17 ft. lbs.).

- 4.11.4 Close the fuel valve and disconnect the fuel line from the carburetor. See the section *Fuel Lines* for removal of fuel and vent lines for models BS 50/60/70/65.
- 4.11.5 Loosen the air duct clamps and remove the air duct.
- 4.11.6 Remove the two socket head cap screws (**c**) holding the carburetor to the engine. When reinstalling the carburetor, apply Loctite 243 and torque the screws to 5.4 Nm (4.0 ft.lbs.).

**Note:** *It is not necessary to disconnect the throttle cable to remove the carburetor.*

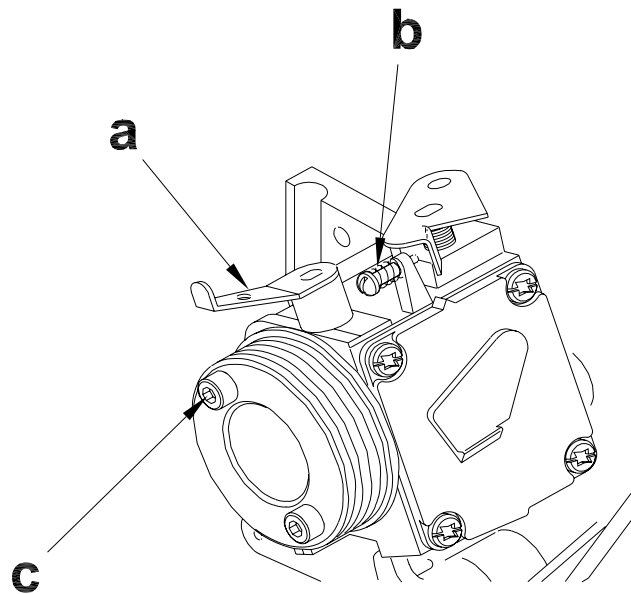

wc\_gr001308rm

## 4.12 Fuel Lines (BS 50/60/70-2, BS 65)

See Graphic: wc\_gr001493



CAUTION

ALWAYS follow the instructions when disconnecting the fuel lines. Failure to do so may result in fuel leaking from the fuel system.

To disconnect the fuel lines:

- 4.12.1 Shut off the engine by moving the throttle through the detent to the off position **(a)**. The engine will stop and the fuel valve will close.
  - 4.12.2 Open the fuel cap **(b)** to relieve normal operating pressure, and then retighten it.
  - 4.12.3 Remove the protective guard.
  - 4.12.4 Pinch off both the fuel feed line **(c)** and the vent line **(d)** as close to the carburetor as possible.
  - 4.12.5 Carefully remove the fuel lines and drain the fuel left in the fuel lines into an approved container.
- Note:** *In the interests of environmental protection, place a plastic sheet and a container under the machine to collect any liquid which drains off. Dispose of this liquid in accordance with environmental protection legislation.*
- 4.12.6 After service is complete, reconnect the lines to the proper fittings. Reconnect the fuel feed line **(c)** from the valve to the lower fitting and the vent line **(d)** from the top of the tank to the upper fitting.
  - 4.12.7 Replace the protective guard.

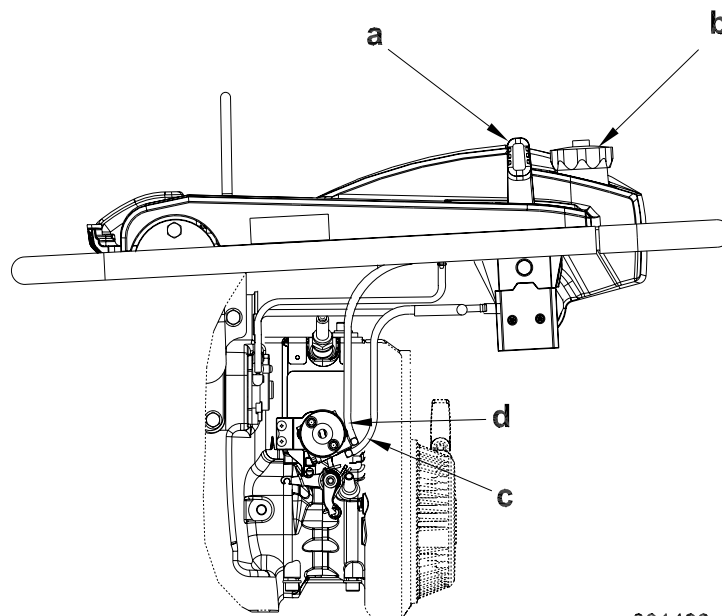

wc\_gr001493



## 4.13 Fuel Tank (BS Models)

See Graphic: *wc\_gr001312rm*

- 4.13.1 Remove the silencing cover.
- 4.13.2 Close the fuel valve (a).
- 4.13.3 Disconnect the fuel line (b) from the fuel tank. Disconnect the vent line (c) where used.
- 4.13.4 Drain the fuel into a suitable container.  
**Note:** *In the interests of environmental protection, place a plastic sheet and a container under the machine to collect any liquid which drains off. Dispose of this liquid in accordance with environmental protection legislation.*
- 4.13.5 Remove the four socket head cap screws that hold the fuel tank to the guide handle. When reinstalling the fuel tank, apply Loctite 243 and torque the screws to 9.4 Nm (6.9 ft. lbs.).
- 4.13.6 Unscrew the filter (d) from the fuel tank.  
**Note:** *It is not necessary to separate the fuel valve from the fuel filter unless replacing the parts. To separate, pull and twist the fuel valve from the fuel filter.*
- 4.13.7 Clean the fuel filter. Replace the fuel filter if the mesh element is torn or punctured.
- 4.13.8 Clean the inside of the fuel tank to remove any sediment.

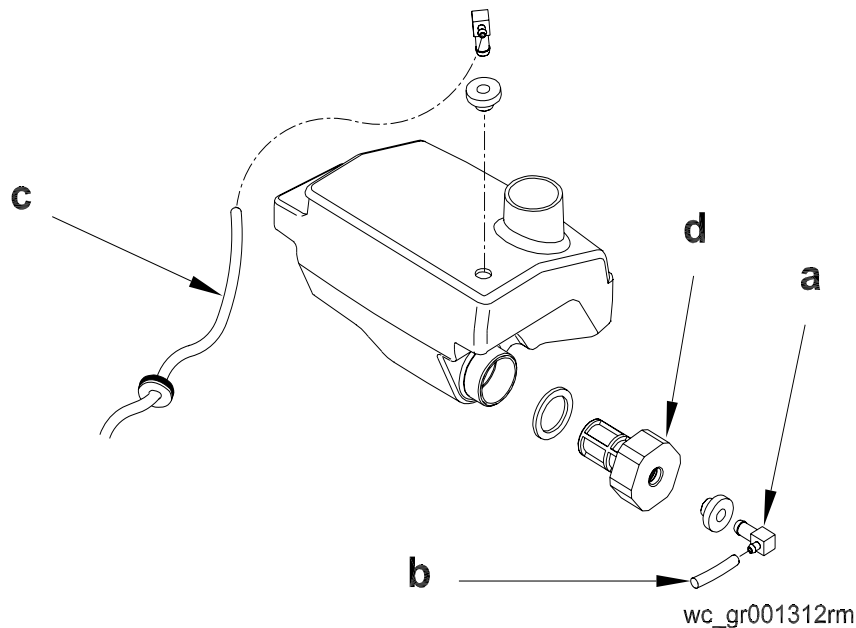

#### 4.14 Fuel Tank (DS Models)

See Graphic: *wc\_gr001313rm*

- 4.14.1 Remove the silencing cover.
- 4.14.2 Disconnect the fuel supply line **(f)** and fuel return line **(c)** from the fuel tank and drain the fuel into a suitable container.  
**Note:** *In the interests of environmental protection, place a plastic sheet and a container under the machine to collect any liquid which drains off. Dispose of this liquid in accordance with environmental protection legislation.*
- 4.14.3 Remove the M6 screw that holds the fuel tank to the guide handle. When reinstalling the fuel tank, apply Loctite 243 and torque the screw to 9.4 Nm (6.9 ft.lbs.).
- 4.14.4 To remove the fuel filter **(b)**, unscrew the two nuts **(e)** holding the fuel supply valve **(d)** to the fuel tank. The fuel supply valve will come off.
- 4.14.5 Unscrew the cap **(a)** from the tank.
- 4.14.6 Carefully remove the fuel filter with needle-nose pliers.
- 4.14.7 Replace the fuel filter if the paper element is torn, punctured, or clogged.
- 4.14.8 Clean the inside of the fuel tank to remove any sediment.

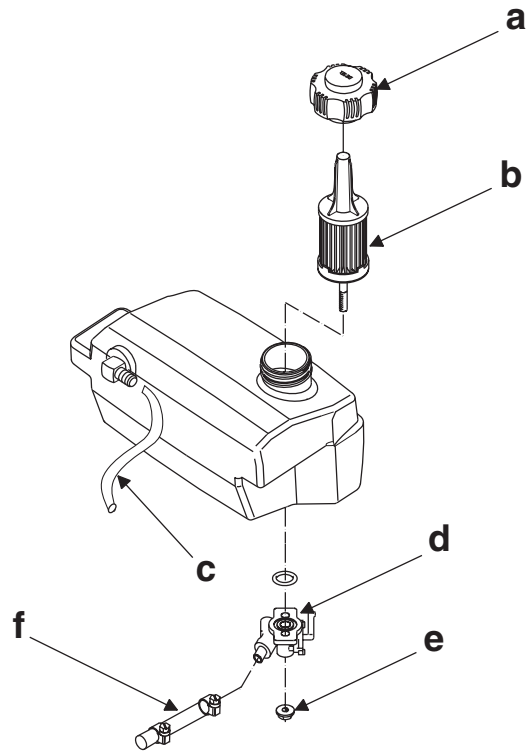

wc\_gr001313rm

## 4.15 Fuel Tank Cap

See Graphic: *wc\_gr004562*

To disassemble and clean the fuel tank cap:

- 4.15.1 Grasp the fuel tank cap **(a)** in one hand and the baffle **(b)** in the other.
- 4.15.2 Pull and twist the baffle left and right to separate it from the fuel tank cap.
- 4.15.3 Remove the fuel tank gasket **(c)** from the baffle.
- 4.15.4 Remove the green umbrella valve **(d)**.
- 4.15.5 Remove the two screws **(e)**, the diaphragm retainer **(f)**, and then the diaphragm itself **(g)**.
- 4.15.6 Clean all parts with soapy water and rinse thoroughly. DO NOT use chemical solvents.

To reassemble the fuel tank cap:

- 4.15.1 Insert the green umbrella valve **(d)** into the top side of the baffle **(b)**. Press on the valve to seat it properly in the baffle.
- 4.15.2 Re-install the diaphragm **(g)** and attach the diaphragm retainer **(f)** with the two screws **(e)**. Torque the screws to 0.28 Nm (2.5 in.lbs.), being careful not to strip them.
- 4.15.3 Re-install the fuel tank gasket **(c)** on the baffle.
- 4.15.4 Place the baffle assembly in the fuel tank cap **(a)**. Use a screwdriver or similar blunt instrument to work the fuel tank gasket into the threads of the fuel tank cap until the baffle assembly snaps into place.

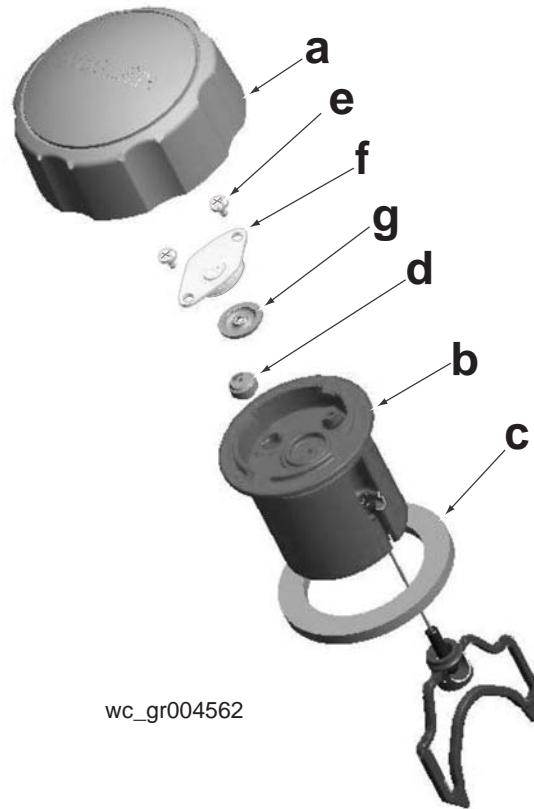

wc\_gr004562

## 4.16 Muffler (pre-2009 BS Models)

See Graphic: *wc\_gr001314rm*

### Recommended Tools

Ratchet wrench  
Torque wrench  
Hex key: 5 mm  
Hex key or hex socket: 6 mm  
Socket: 19 mm (3/4")  
Loctite 243 (blue)

Carbon deposits can form in the muffler **(d)** and in the cylinder exhaust port. If allowed to accumulate, they will gradually restrict the exhaust passages, resulting in poor engine performance and hard starting. Factors contributing to this problem include:

- Too much oil in the fuel mixture
- Dirty air filter causing the engine to run rich
- Excessive engine idling
- Dirty carburetor

- 4.16.1 Remove the two hex head cap screws **(a)** holding the muffler guard **(b)** to the muffler **(d)**. When reinstalling the muffler guard, apply Loctite 243 and torque the screws to 35 Nm (25 ft.lbs.).
- 4.16.2 Remove the two socket head cap screws **(f)** holding the muffler and the muffler guard to the engine cylinder. When reinstalling the muffler and the muffler guard, apply Loctite 243 and torque the screws to 23 Nm (17 ft.lbs.).
- 4.16.3 Remove the two socket head cap screws **(c)** located inside the muffler.
- 4.16.4 Remove the muffler.
- 4.16.5 Slowly pull the starter rope until the piston is at the top of its stroke and is covering the exhaust port. This prevents dirt from entering the engine cylinder.
- 4.16.6 Remove any carbon deposits on the engine exhaust port with a blunt scraper.
- 4.16.7 Replace the silencer gasket **(e)**.
- 4.16.8 Soak the muffler in carburetor cleaner or a similar cleaning solution for several hours.
- 4.16.9 Drain the muffler and blow it dry.

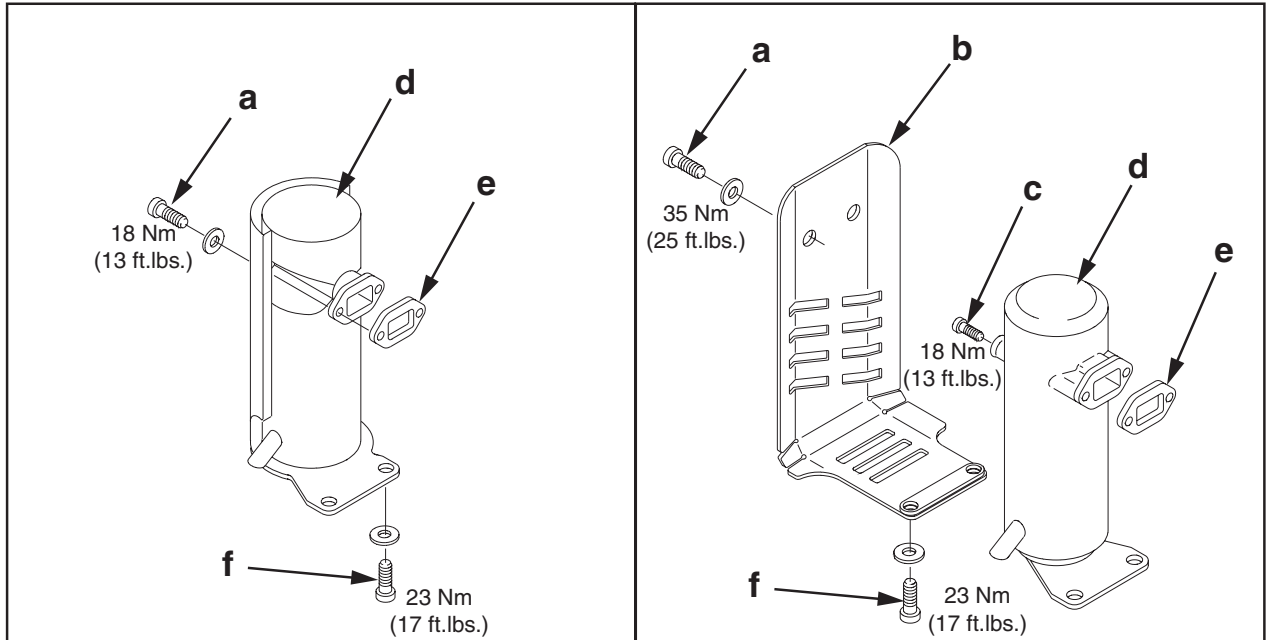

wc\_gr001314rm

## 4.17 Engine Cooling Fins

### Recommended Tools

Screwdriver  
Compressed air

The Wacker WM 80 engine is air cooled, so dirt accumulation between the cylinder ribs may cause the engine to overheat. Use a screwdriver to remove any dirt that is impacted between the cylinder ribs. Clean the entire area using compressed air.

## 4.18 Muffler (DS Models)

See Graphic: *wc\_gr001315rm*

### Recommended Tools

Ratchet wrench  
Torque wrench  
Hex key: 5 mm  
Hex key or hex socket: 6 mm  
Socket: 19 mm (3/4")  
Loctite 243 (blue)

Carbon deposits can form in the muffler **(a)** and in the cylinder exhaust port. If allowed to accumulate, they will gradually restrict the exhaust passages resulting in poor engine performance and hard starting. Factors contributing to this problem include:

- Dirty air filter causing the engine to run rich
- Excessive engine idling

- 4.18.1 Remove the two nuts **(b)** and two screws **(c)** holding the muffler to the engine cylinder. When reinstalling the muffler, apply Loctite 243 and torque the screws to 23 Nm (17 ft.lbs.).
- 4.18.2 Remove the muffler.
- 4.18.3 Remove any carbon deposits on the engine exhaust port with a blunt scraper.
- 4.18.4 Replace the muffler gasket **(d)** P/N 0073660.
- 4.18.5 Soak the muffler in carburetor cleaner or a similar cleaning solution for several hours.
- 4.18.6 Drain the muffler and blow it dry.



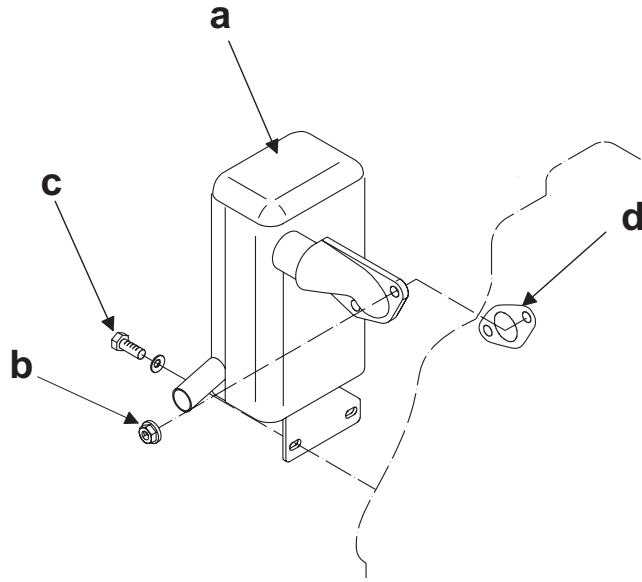

wc\_gr001315rm

## 4.19 Replacing the Carburetor (WM 80 engines)

### Removal

Removing Walbro Carburetor (auto-release choke models)

4.19.1 Stop the machine and allow it to cool.

4.19.2 Remove the carburetor guard (a).

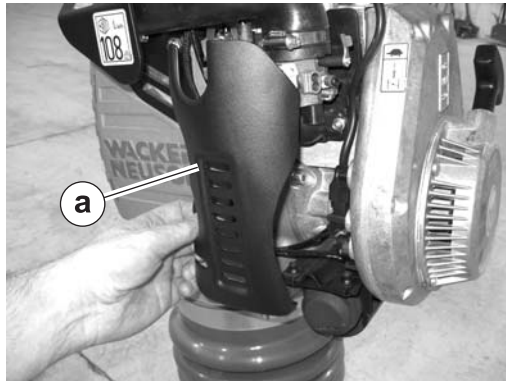

wc\_gr007416

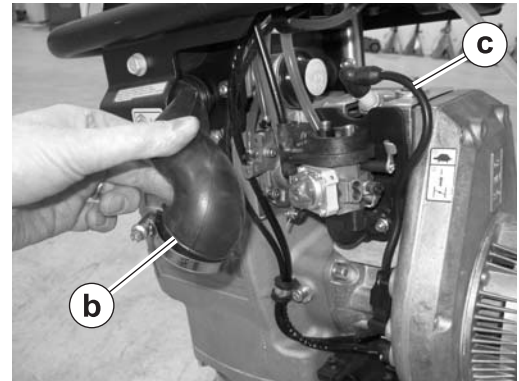

wc\_gr007417

4.19.3 Loosen the hose clamp and remove the air duct (b).

4.19.4 Disconnect the ignition wire (c) from the spark plug.

4.19.5 Loosen the clamp (d) and remove the throttle cable (e) from the carburetor adapter (f).

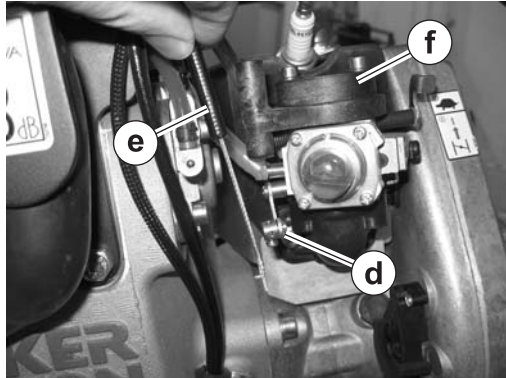

wc\_gr007418

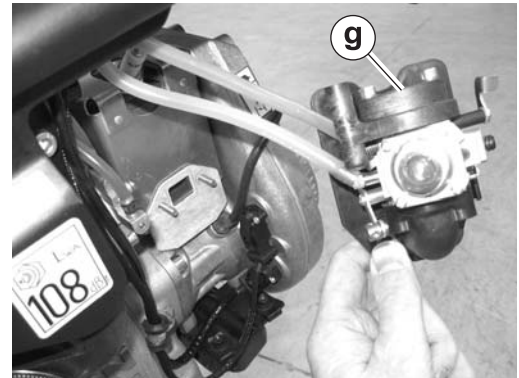

wc\_gr007419

4.19.6 Remove the two nuts and washers and remove the carburetor assembly (g) from the machine.

*This procedure continues on the next page.*

*Continued from the previous page.*

- 4.19.7 Have a container ready, then remove the oil hose (h) and drain it.

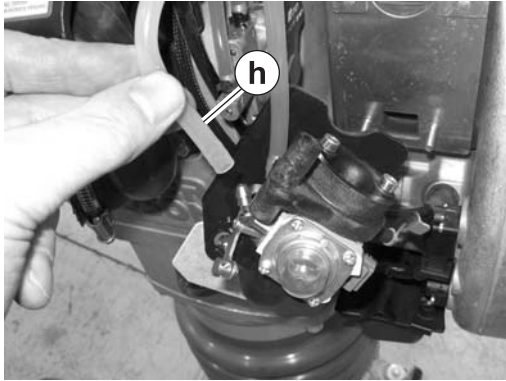

wc\_gr007420

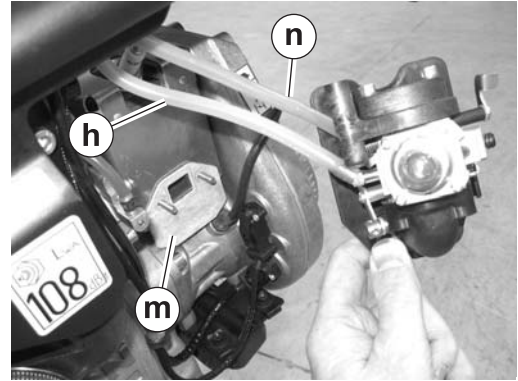

wc\_gr007455

- 4.19.8 Make sure the throttle is in the OFF position. This position also closes the fuel valve. Then, remove the fuel hose (n) and drain it.

- 4.19.9 Remove the gasket (m).

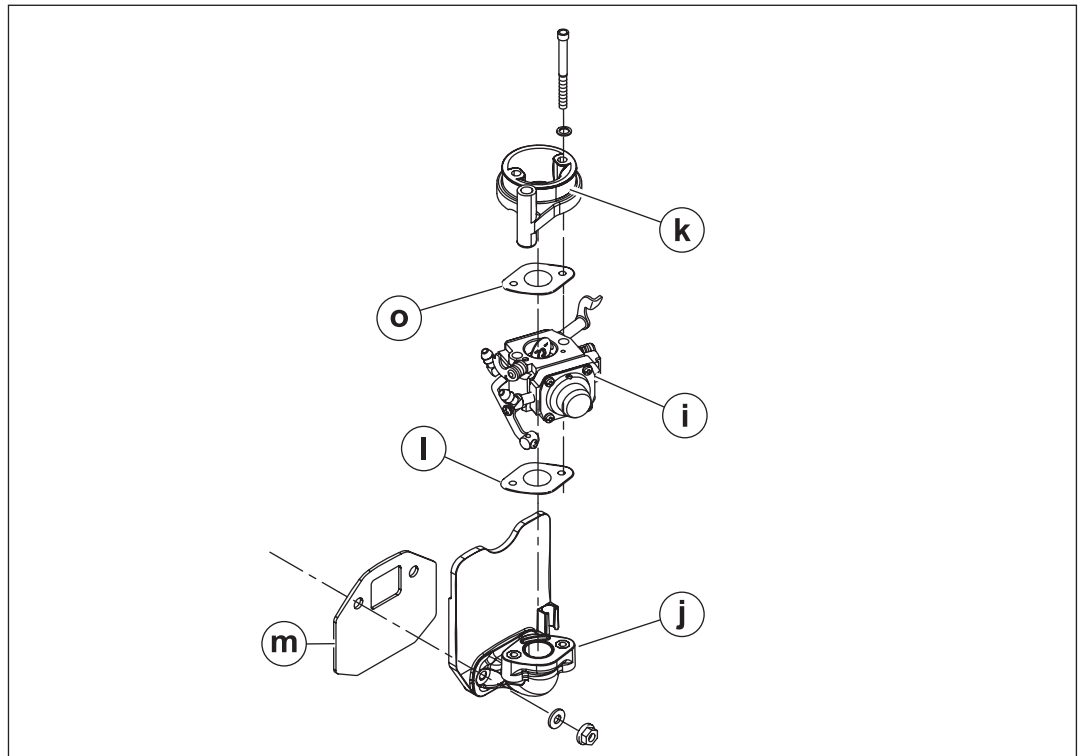

wc\_gr007421

- 4.19.10 Disassemble the carburetor (i) from the adapter (j), flange (k), and gaskets (l and o).

## Result

The removal procedure is now complete.

## Installation

Perform the procedure below to install the carburetor

- 4.19.1 Assemble the adapter (**j**), lower gasket (**l**), flange (**k**), and upper gasket (**o**) to the carburetor (**i**). **Note:** *The gaskets are not interchangeable.*

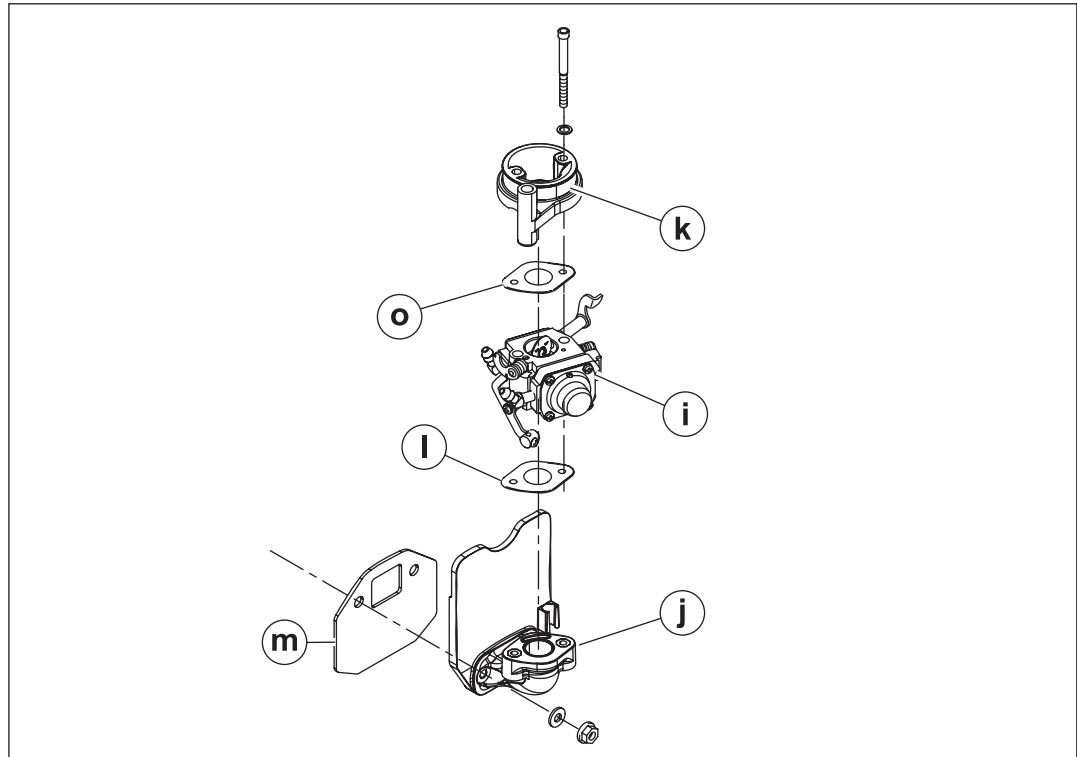

wc\_gr007421

- 4.19.2 Connect the oil hose (**h**), and the fuel hose (**n**), to the carburetor.

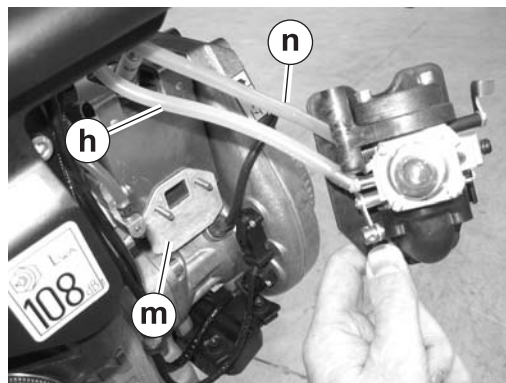

wc\_gr007455

- 4.19.3 Install the carburetor assembly to the engine.

- 4.19.4 Slide the throttle cable (e) through the adapter (f) and reconnect it to the clamp (d).

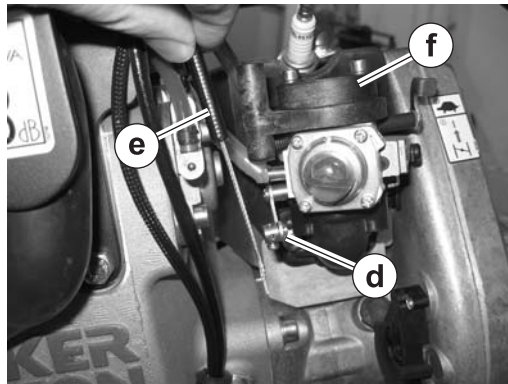

wc\_gr007418

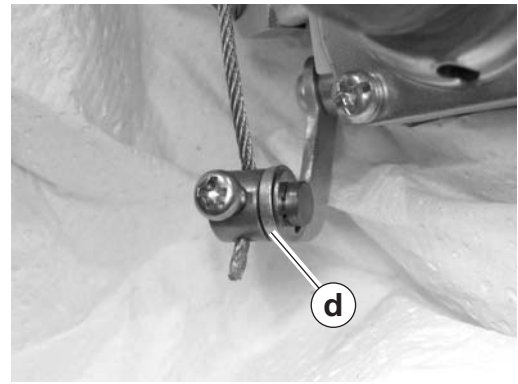

wc\_gr007456

- 4.19.5 Install the air duct (b) with the hose clamp.

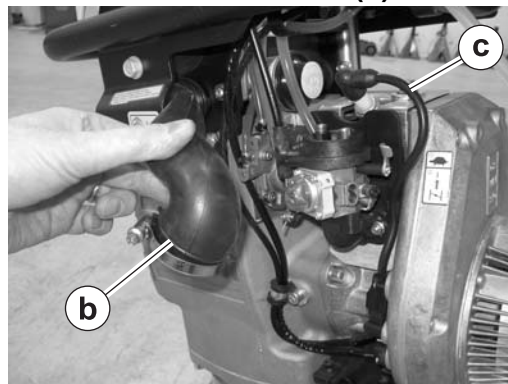

wc\_gr007417

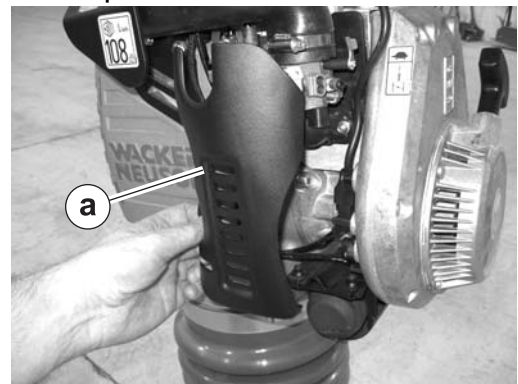

wc\_gr007416

- 4.19.6 Using Loctite® 243 on the screws, install the carburetor guard (a).

## Result

The installation procedure is now complete.

## 4.20 Replacing the WM 80 Engine (2010 and later models)

### Requirements

- Engine cool
- Carburetor removed

### Removal

Perform the procedure below to remove the engine.

4.20.1 Remove the carburetor.

4.20.2 Remove the muffler (a).

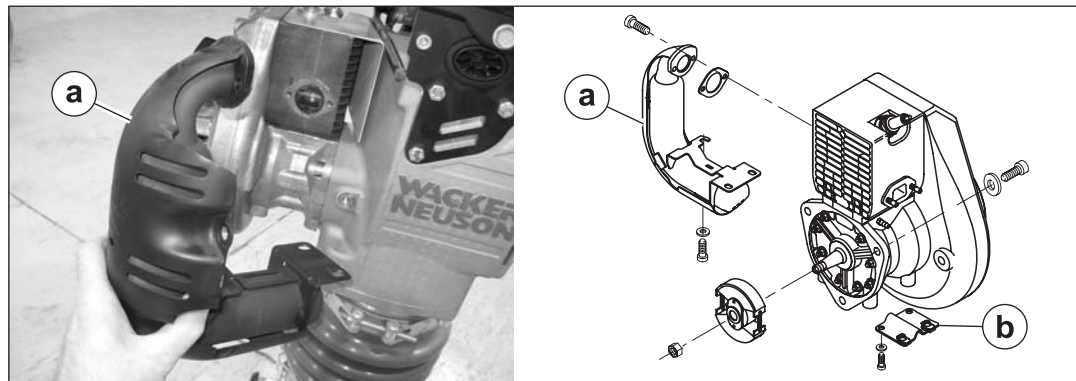

wc\_gr007450

4.20.3 Remove the bracket (b).

4.20.4 Disconnect the wiring to the switches (c).

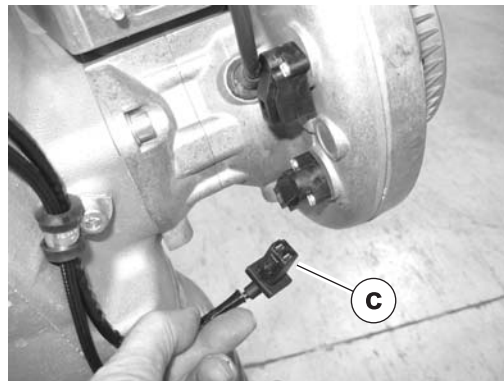

wc\_gr007451

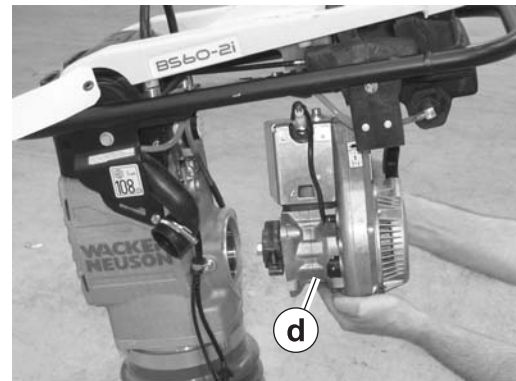

wc\_gr007452

4.20.5 Remove the screws that hold the engine and remove the engine (d) from the machine.

### Result

The engine has now been removed.

## Installation

Perform the procedure below to install the engine.

- 4.20.1 Install the engine **(d)** to the machine with three screws. Torque the screws to 28 Nm (20 ft.lbs.).

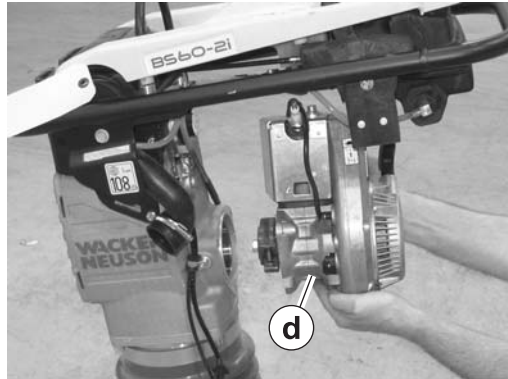

wc\_gr007452

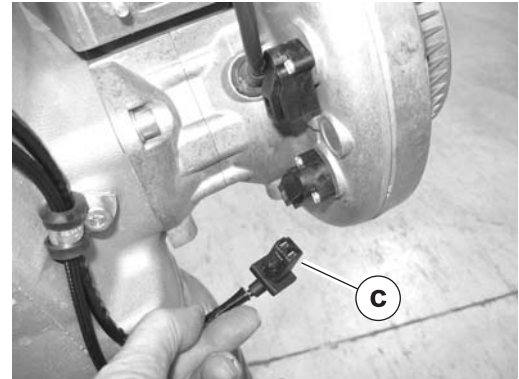

wc\_gr007451

- 4.20.2 Reconnect the wiring **(c)** to the switches.

- 4.20.3 Install the bracket **(b)**.

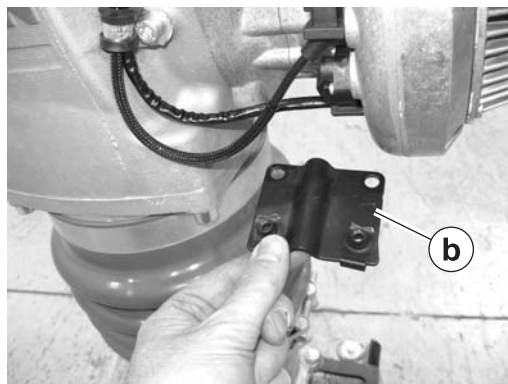

wc\_gr007453

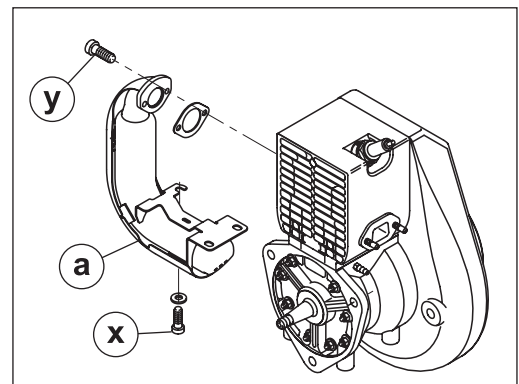

wc\_gr007555

- 4.20.4 Install the muffler **(a)**. Torque screws **(x)** to 18 Nm (13 ft.lbs.). Torque screw **(y)** to 23 Nm (16 ft.lbs.).

- 4.20.5 Install the carburetor.

## Result

The engine has now been installed.

## 4.21 Replacing the WM 80 Engine (pre-2010 models)

See Graphic:wc\_gr002935

Removal:

- 4.21.1 Stop the machine and allow it to cool.
- 4.21.2 Remove the carburetor. See section *Removing Carburetor*.
- 4.21.3 Remove the muffler guard **(a)** (if equipped) and the muffler **(b)**.
- 4.21.4 Disconnect the connector **(c)** from the stop switch.
- 4.21.5 Remove the three socket head cap screws **(d)** that hold the engine to the crankcase.
- 4.21.6 Tilt the engine down and away to remove it from the crankcase.

**NOTICE:** The rammer tips easily when the engine is removed.



**DO NOT** run the engine while it is off the machine unless the clutch **(e)** has been removed. Running the engine with the clutch attached to the crankshaft will cause the clutch shoes to separate and fly off.

Installation:

- 4.21.7 Position the engine onto the machine. Using Loctite 234 or equivalent on the three screws **(d)**, secure the engine to the machine. Torque the screws to 27 Nm (20 ft.lbs.).
- 4.21.8 Reconnect the stop switch.
- 4.21.9 Install the muffler **(b)** and muffler guard **(a)**.
- 4.21.10 Install the carburetor. See section *Removing Carburetor*.



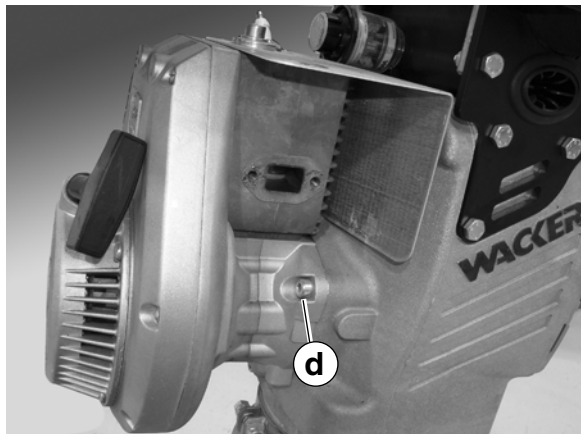
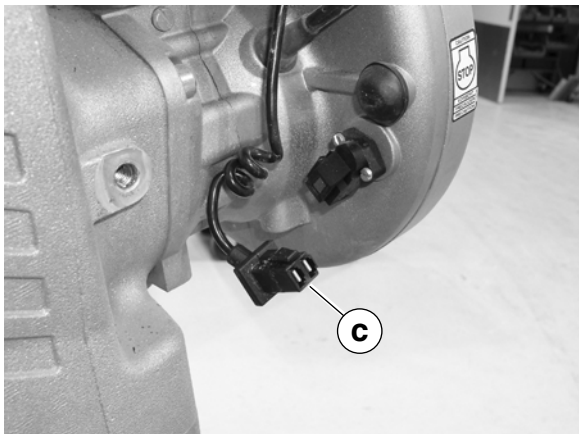
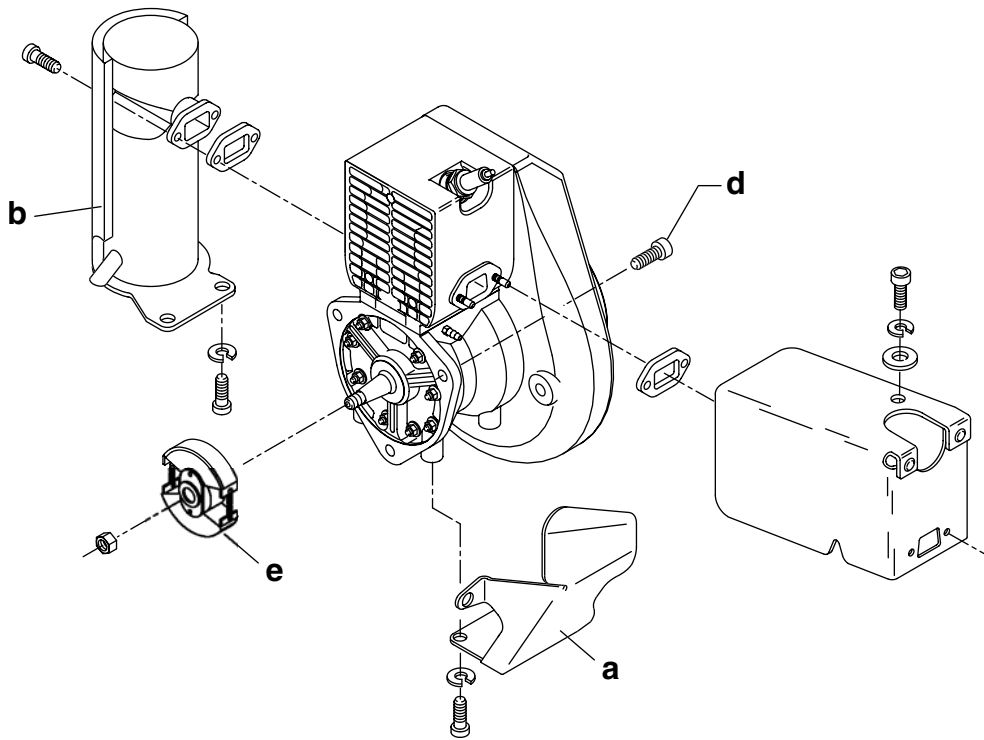
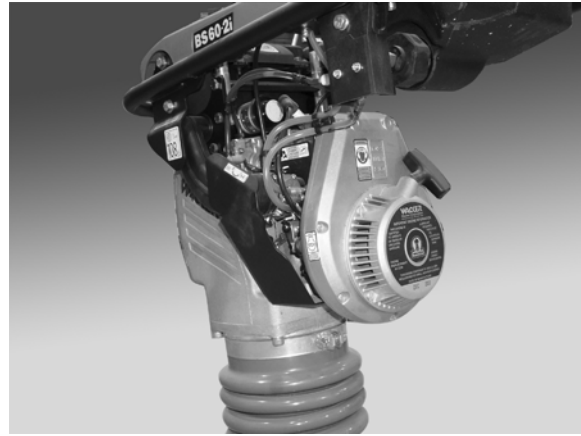

wc\_gr002935

## 4.22 Replacing the Carburetor (WM 100 Engines)

### Requirements

- Machine shut down and cool
- Loctite® 243 or equivalent
- Torque wrench

### Removal

Perform the procedure below to remove the engine.

4.22.1 Disconnect the spark plug.

4.22.2 Remove the side guard (a).

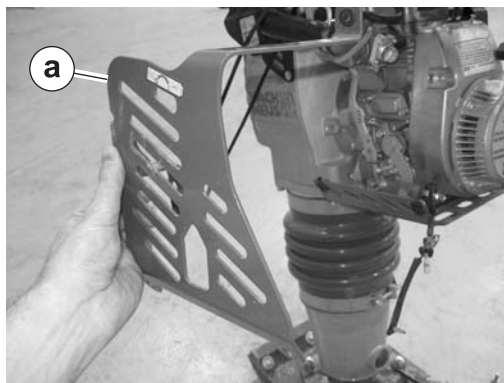

wc\_gr007500

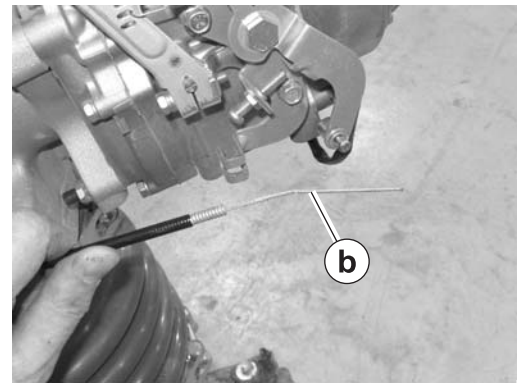

wc\_gr007503

4.22.3 Disconnect the throttle cable (b).

4.22.4 Disconnect the air hose (c).

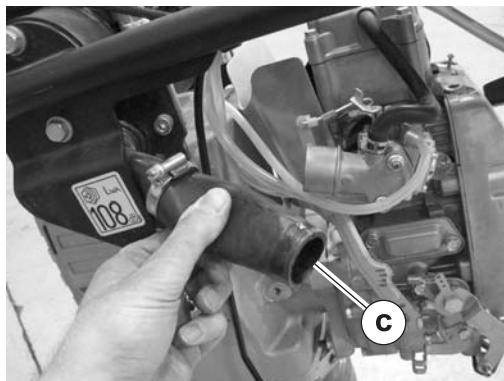

wc\_gr007504

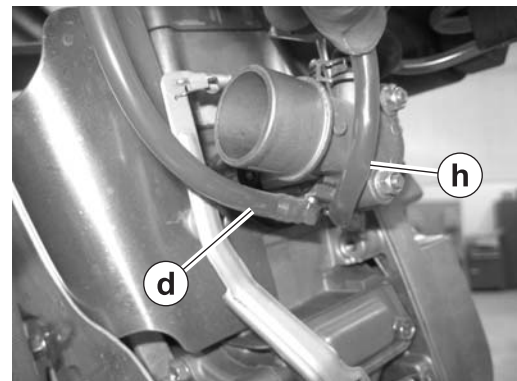

wc\_gr007505

4.22.5 Disconnect the fuel hose (d) and the compensation hose (h).

*This procedure continues on the next page.*

*Continued from the previous page.*

4.22.6 Disconnect the hose (e).

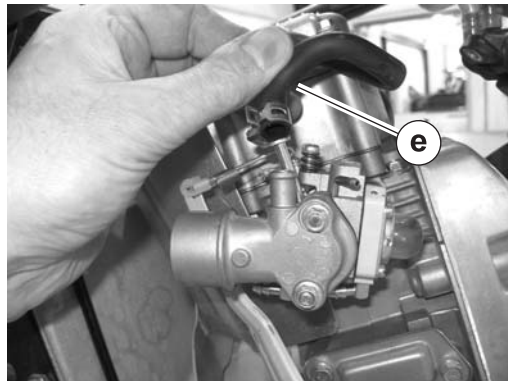

wc\_gr007506

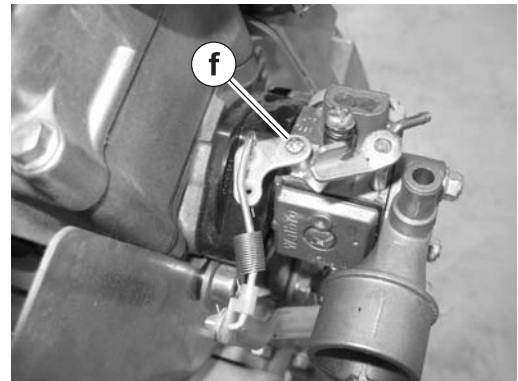

wc\_gr007507

4.22.7 Remove screw (f) and disconnect the linkage.

4.22.8 Remove the carburetor (g).

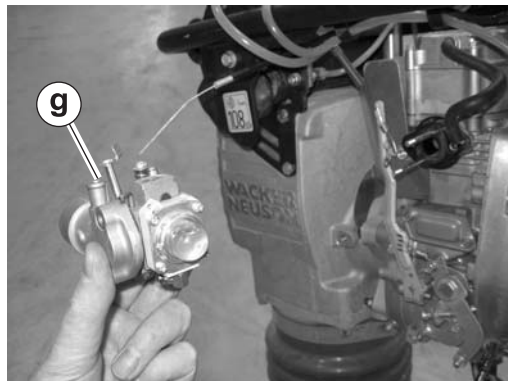

wc\_gr007508

## Result

The removal procedure is now complete.

## Installation

Perform the procedure below to install the carburetor.

4.22.1 Install the carburetor (g), gaskets (h), and adapter (i).

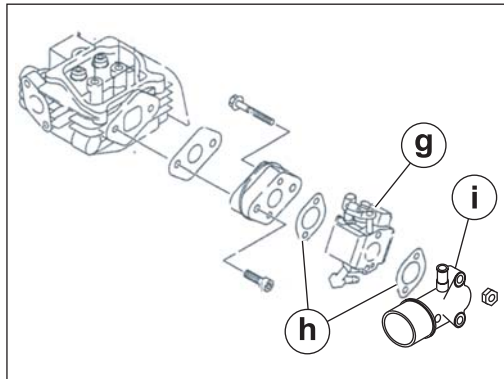

wc\_gr007509

4.22.2 Reconnect the linkage with screw (f).

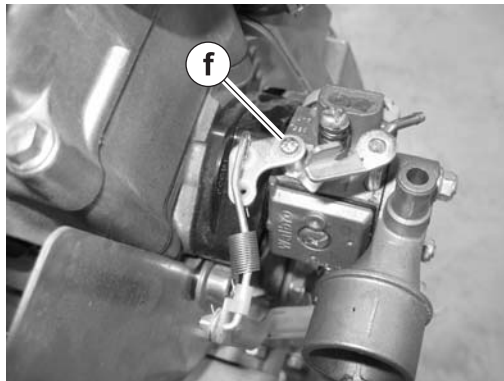

wc\_gr007507

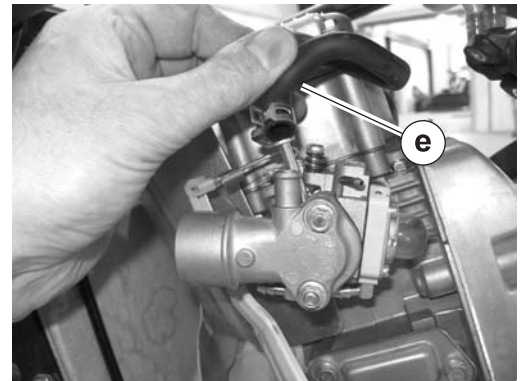

wc\_gr007506

4.22.3 Reconnect the hose (e).

4.22.4 Reconnect the fuel hose (d) and the compensation hose (h).

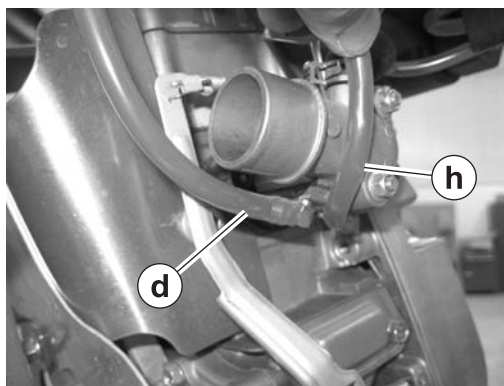

wc\_gr007505



wc\_gr007504

4.22.5 Reconnect the air hose (c).

*This procedure continues on the next page.*

*Continued from the previous page.*

## 4.22.6 Reconnect the throttle cable (b).

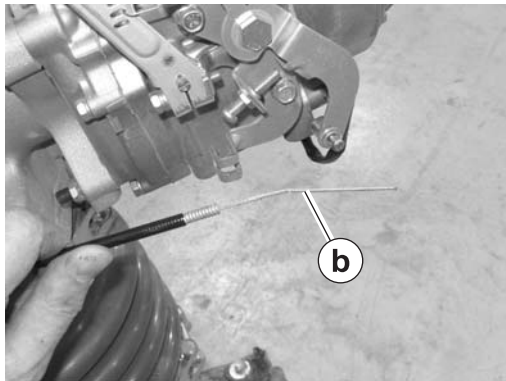

wc\_gr007503

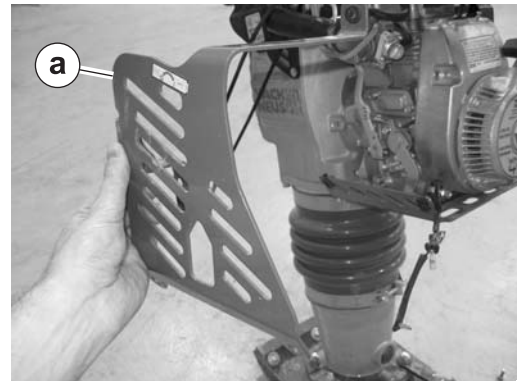

wc\_gr007500

## 4.22.7 Install the side guard (a).

### Result

The replacement procedure is now complete.

## 4.23 Replacing the WM 100 Engine

### Requirements

- Machine shut down and cool
- Loctite® 243 or equivalent
- Torque wrench
- Two wire ties

### Removal

Perform the procedure below to remove the engine.

4.23.1 Remove the carburetor. See topic *Replacing the Carburetor (WM 100 engine)*.

4.23.2 Clip the wire ties (**h**).



wc\_gr007518

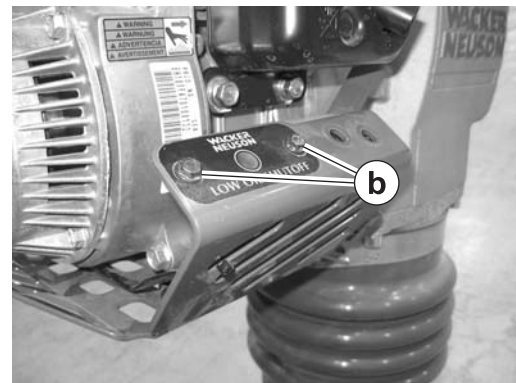

wc\_gr007501

4.23.3 Remove the screws (**b**) that hold the low oil shutdown switch.

4.23.4 Remove the lower guard (**c**).

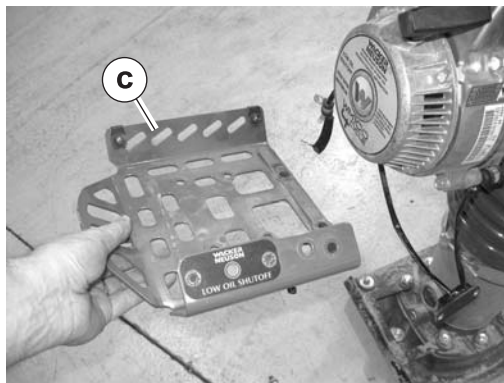

wc\_gr007511

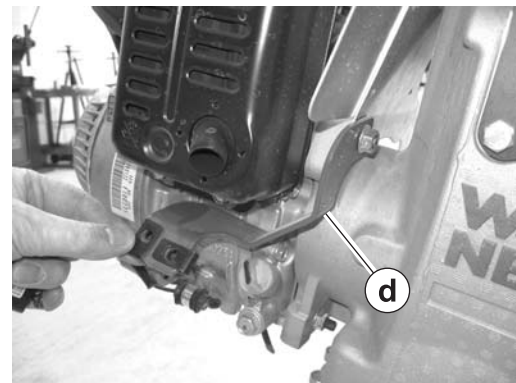

wc\_gr007512

4.23.5 Remove the support bracket (**d**).

*This procedure continues on the next page.*

*Continued from the previous page.*

4.23.6 Remove the heat shield (a).

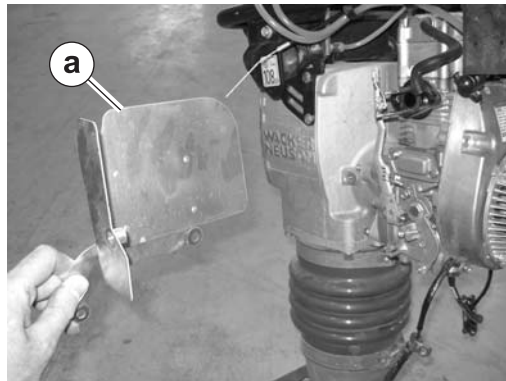

wc\_gr007510

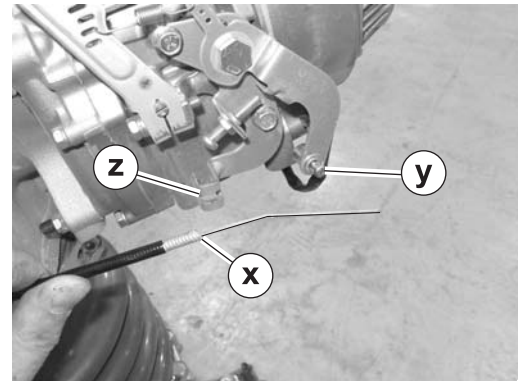

wc\_gr007515

4.23.7 Disconnect the throttle cable (x) at the swivel (y) and the clamp (z).

4.23.8 Remove the nuts that hold the engine and remove the engine (e) from the machine.

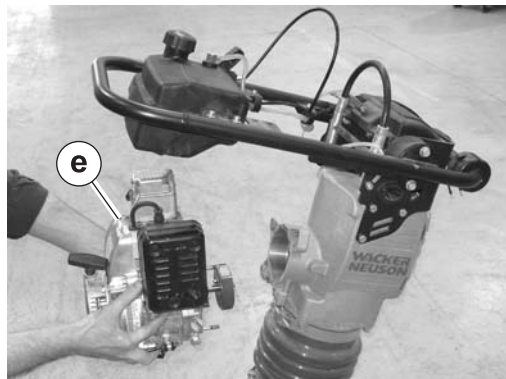

wc\_gr007513

## Result

The removal procedure is now complete.

## Installation

Perform the procedure below to install the engine.

- 4.23.1 Apply Loctite® 243 to the four engine studs (**w**).

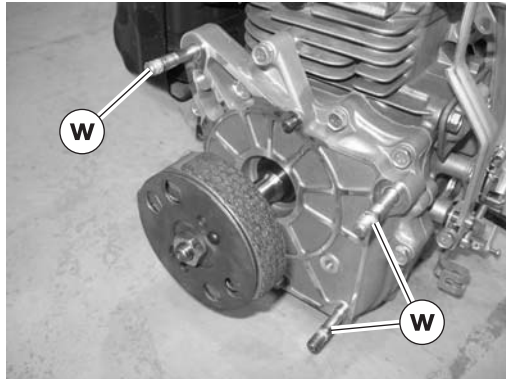

wc\_gr007514

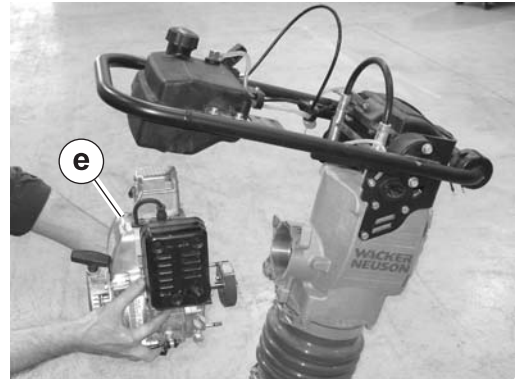

wc\_gr007513

- 4.23.2 Slide the engine (**e**) (with clutch installed) into the machine.

- 4.23.3 Loosely install the support bracket (**d**) and heat shield (**a**) with nut (**n**). Install the other three nuts and torque them to 25 Nm (18 ft.lbs.).

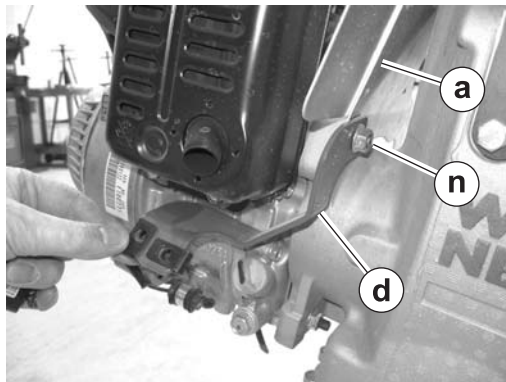

wc\_gr007516

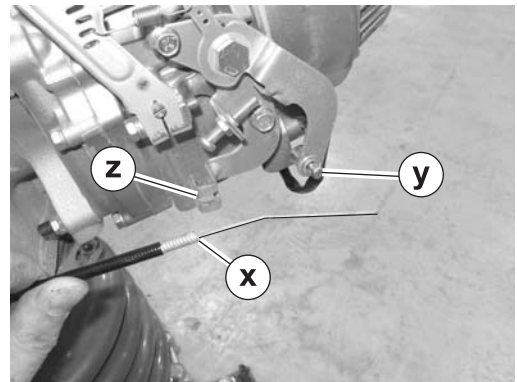

wc\_gr007515

- 4.23.4 Reconnect the throttle cable (**x**) to the swivel (**y**) and the clamp (**z**).

*This procedure continues on the next page.*



*Continued from the previous page.*

- 4.23.5 Fit the lower guard to the support bracket. Then, using Loctite® 243 on the screws, install the lower guard **(c)** to the engine. Torque the screws to 25 Nm (18 ft.lbs.). Torque the support bracket screw **(n)** to 25 Nm (18 ft.lbs.).

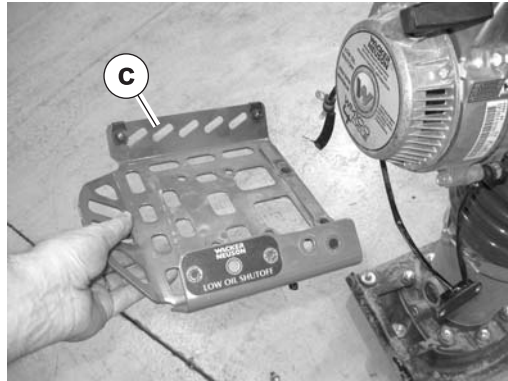

wc\_gr007511

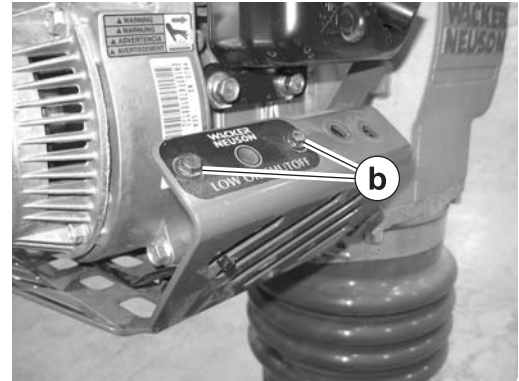

wc\_gr007501

- 4.23.6 Install the low oil shutdown switch with screws **(b)**.

- 4.23.7 Secure the wiring with new wire ties **(h)**.



wc\_gr007518

- 4.23.8 Reinstall the carburetor. See topic *Replacing the Carburetor*.

## Result

The replacement procedure is now complete.

## 4.24 Removing the WM 90 Engine

See Graphic: *wc\_gr001954, wc\_gr003661, wc\_gr001956, and wc\_gr001957*

- 4.24.1 Disconnect the spark plug cap **(a)** from the spark plug.
- 4.24.2 Disconnect the fuel line **(b)** from the carburetor and plug the line.
- 4.24.3 Disconnect the stop switch wire **(c)**.
- 4.24.4 Disconnect the wiring **(k)** from the low-oil unit **(l)** (if equipped).
- 4.24.5 Remove the M8 x 16 bolt and washer **(d)** securing the guard to the engine.
- 4.24.6 Remove the M8 bolt and washer **(e)** securing the guard to the rammer crankcase.
- 4.24.7 Remove the six M8 bolts **(f)** securing the lower guard to the engine and remove the guard.
- 4.24.8 Remove the wire running from the engine to the low-oil unit (if equipped).
- 4.24.9 Loosen the retainer **(g)** from the throttle cable. Pry open the clamp **(h)** and remove the throttle cable.
- 4.24.10 Loosen the clamp **(i)** securing the air intake hose to the carburetor and remove the hose.
- 4.24.11 Remove the four nuts **(j)** securing the engine to the adapter and remove the heat shield and the engine.

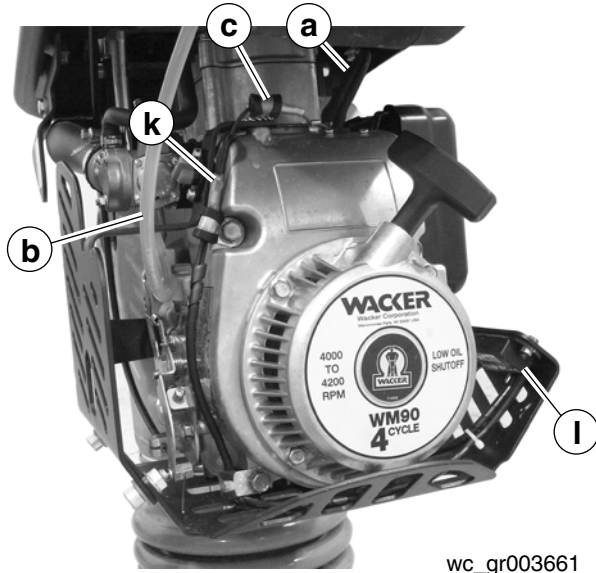

wc\_gr003661

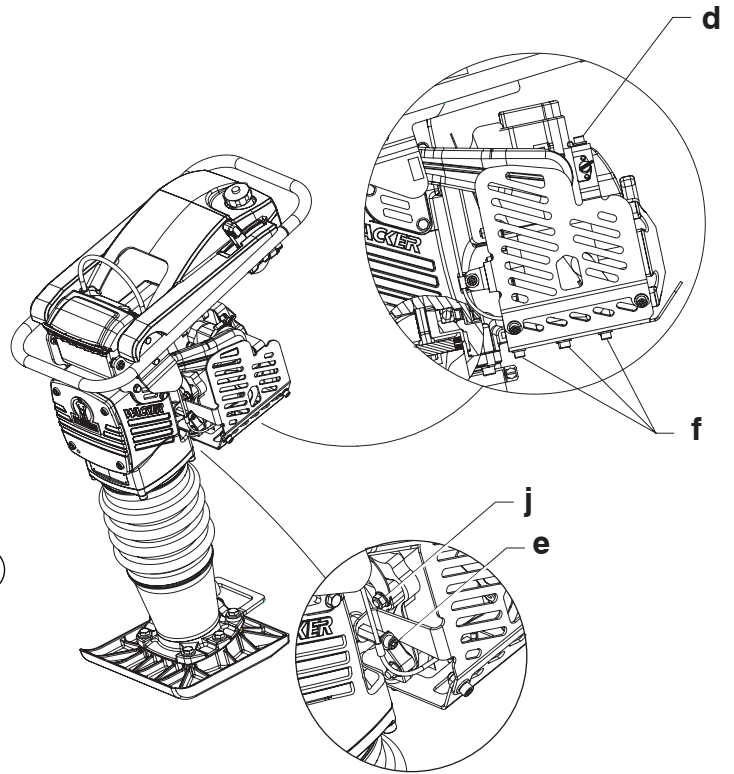

wc\_gr001954

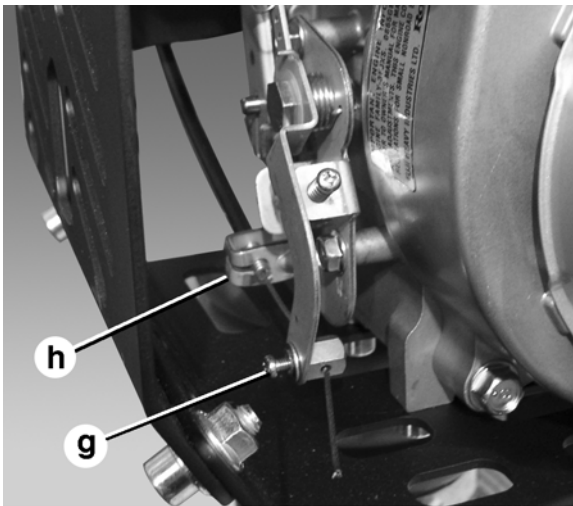

wc\_gr001956

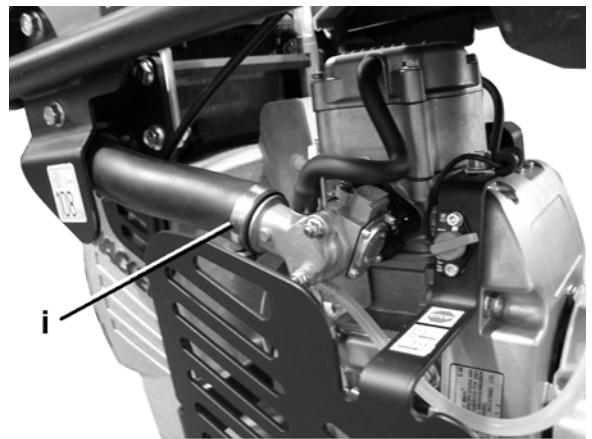

wc\_gr001957

## 4.25 Engine (DS Models)

See Graphic: *wc\_gr001317rm*

### Recommended Tools

Ratchet wrench

Torque wrench

Socket: 19 mm (3/4")

Hex key: 5 mm

Hex key or hex socket: 4 mm, 6 mm

Screwdriver

- 4.25.1 Close the fuel valve.
- 4.25.2 Disconnect the fuel lines.
- 4.25.3 Loosen the throttle cable holder.
- 4.25.4 Disconnect the throttle cable.
- 4.25.5 Remove the four M10 nuts (**a**) that hold the engine to the crankcase. When reinstalling the engine, torque the nuts to 49 Nm (36 ft.lbs.).
- 4.25.6 Tilt the engine down and away to remove it from the crankcase.

**NOTICE:** The rammer tips easily when the engine is removed.



**DO NOT** run the engine while it is detached from the machine unless the clutch has been removed. Running the engine with the clutch attached to the crankshaft will cause the clutch shoes to separate and fly off.

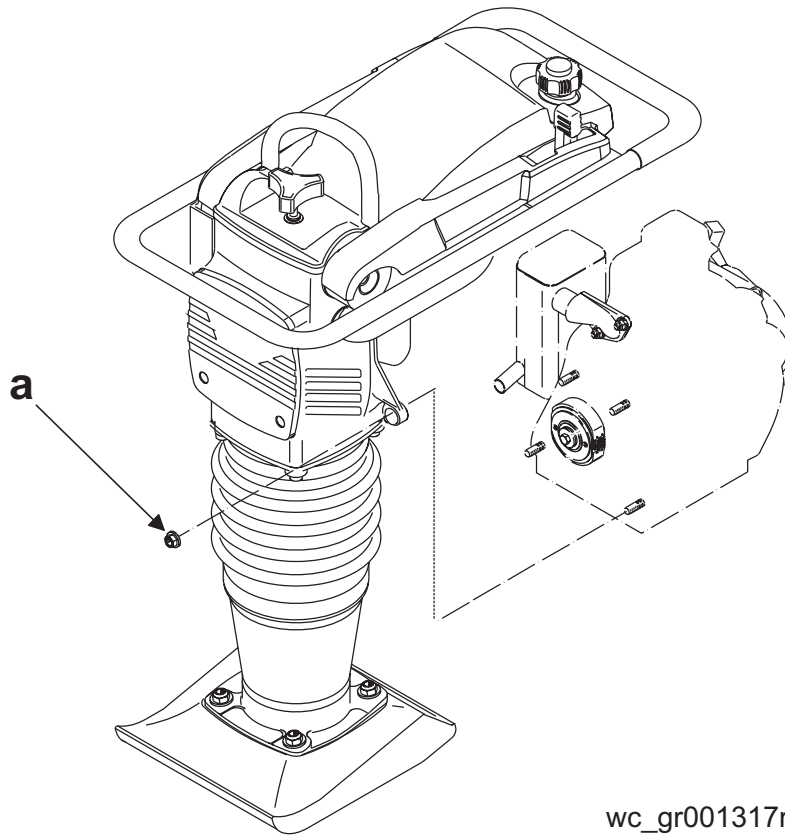

wc\_gr001317rm

## 4.26 Clutch (2- and 4-stroke models)

See Graphic: *wc\_gr007517*

### Recommended Tools

Impact wrench  
Torque wrench  
Socket: 17 mm  
Needle-nose pliers  
Clutch puller P/N 0117972

### Removal

- 4.26.1 Remove the engine from the rammer.
- 4.26.2 Check the condition of the clutch shoes **(a)** and replace them if necessary. The clutch shoes should be absolutely dry. If oil is present, inspect the engine shaft seal.
- 4.26.3 Prevent the clutch from turning and use an air impact wrench and 17 mm socket to loosen the clutch nut **(b)**. If an impact wrench is not available, rap the wrench handle sharply to help break the nut loose.

**Note:** *Loosen the nut but do not completely remove it from the engine crankshaft. This will protect the crankshaft threads from the clutch puller screw.*

- 4.26.4 Screw the clutch puller (P/N 0117972) **(c)** (or other suitable puller) into the small holes in the clutch and turn the center screw against the end of the crankshaft until the clutch hub breaks free of the taper.

**Note:** *When reinstalling the clutch, make sure the taper in the clutch hub and on the engine crankshaft is absolutely free of any oil or grease.*

### Installation

- 4.26.5 Place the clutch on the engine crankshaft.
- 4.26.6 Reinstall the clutch nut and torque to 35 Nm (25 ft.lbs.).
- 4.26.7 Reinstall the engine on the crankcase.

BS Models

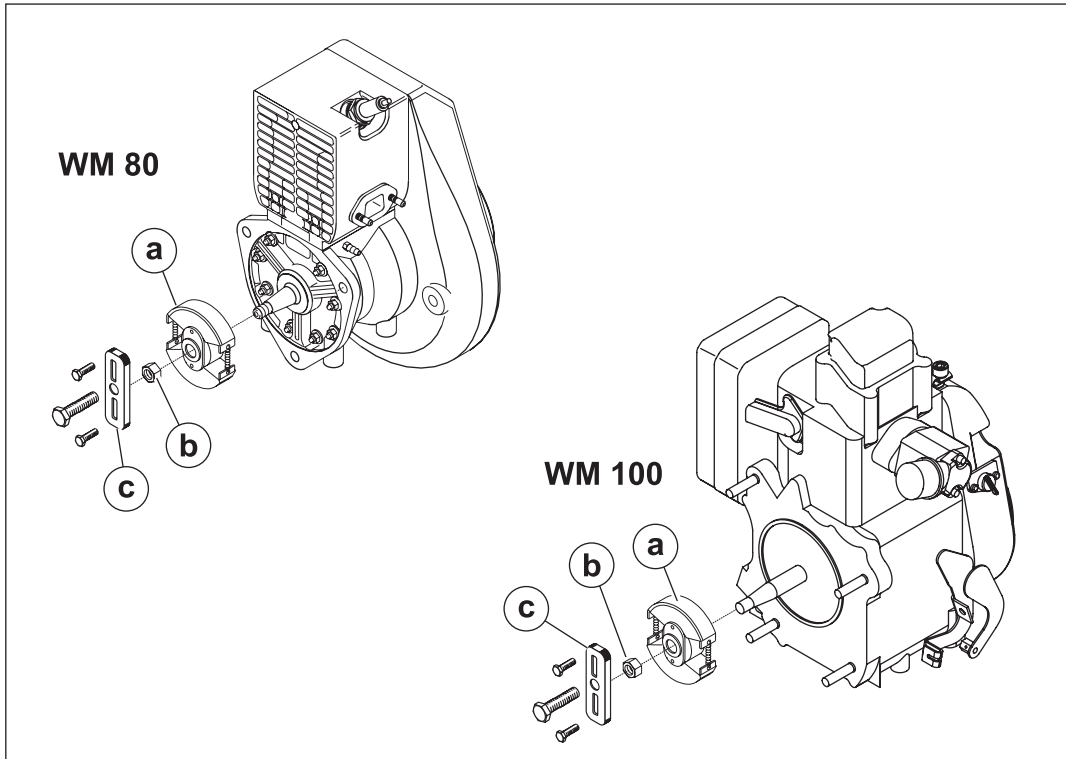

wc\_gr007517

## 4.27 Clutch (DS 720 only)

See Graphic: *wc\_gr001319rm*

### Recommended Tools

Impact wrench  
Torque wrench  
Needle-nose pliers  
Clutch puller P/N 0153566

### Removal

- 4.27.1 Remove the engine from the rammer.
- 4.27.2 Check the condition of the clutch shoes **(a)** and replace them if necessary. The clutch shoes should be absolutely dry. If oil is present, inspect the engine shaft seal.
- 4.27.3 Prevent the clutch from turning and use an air impact wrench to loosen the clutch bolt **(b)**. If an impact wrench is not available, rap the wrench handle sharply to help break the bolt loose.

**Note:** *Loosen the bolt but do not completely remove it from the engine crankshaft. This will protect the crankshaft threads from the clutch puller screw.*

- 4.27.4 Screw the clutch puller (P/N 0153566) **(c)** (or other suitable puller) into the small holes in the clutch and turn the center screw against the end of the crankshaft until the clutch hub breaks free of the taper.

**Note:** *When reinstalling the clutch, make sure the taper in the clutch hub and on the engine crankshaft is absolutely free of any oil or grease.*

### Installation

- 4.27.5 Place the clutch on the engine crankshaft.
- 4.27.6 Reinstall the clutch bolt and torque to 27 Nm (20 ft.lbs.).
- 4.27.7 Reinstall the engine on the crankcase. Torque the screws to 49 Nm (36 ft.lbs.).
- 4.27.8 Perform an operation check. The clutch should be disengaged with the throttle at the idle position.

Engine Speed (idle) (rpm): 1200 ± 200

Clutch Engagement (rpm): 2000 ± 200



DS 720 Models

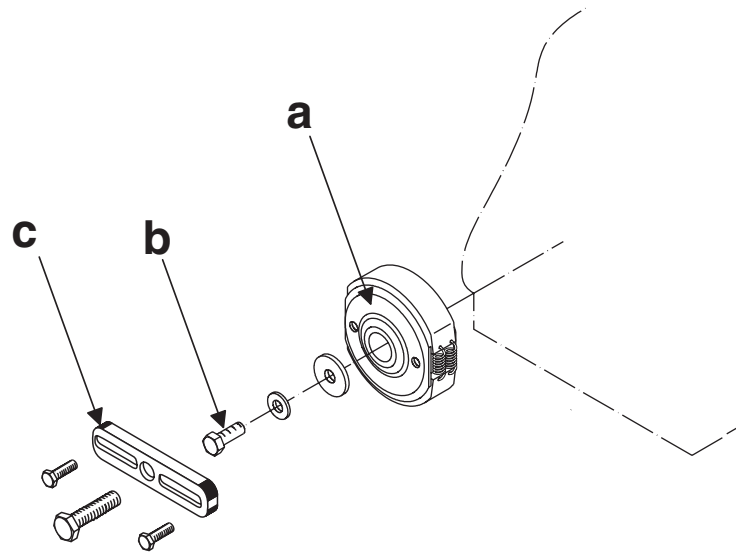

wc\_gr001319rm

## 4.28 Clutch (DS 70 only)

See Graphic: *wc\_gr002372rm*

### Recommended Tools

Impact wrench  
Torque wrench  
Needle-nose pliers  
Clutch puller P/N 0153566

### Removal

- 4.28.1 Remove the engine from the rammer.
- 4.28.2 Check the condition of the clutch shoes **(a)** and replace them if necessary. The clutch shoes should be absolutely dry. If oil is present, inspect the engine shaft seal.
- 4.28.3 Prevent the clutch from turning and use an air impact wrench to loosen the clutch bolt **(b)**. If an impact wrench is not available, rap the wrench handle sharply to help break the bolt loose.

**Note:** *Loosen the bolt but do not completely remove it from the engine crankshaft. This will protect the crankshaft threads from the clutch puller screw.*

- 4.28.4 Screw the clutch puller (P/N 0153566) **(c)** (or other suitable puller) into the small holes in the clutch and turn the center screw against the end of the crankshaft until the clutch hub breaks free of the taper.

### Installation

- 4.28.5 Place the clutch on the engine crankshaft.
- 4.28.6 Reinstall the clutch bolt and torque to 27 Nm (20 ft.lbs.).
- 4.28.7 Reinstall the engine on the crankcase. Torque the screws to 49 Nm (36 ft.lbs.).
- 4.28.8 Perform an operation check. The clutch should be disengaged with the throttle at the idle position.

Engine Speed (idle) (rpm): 1050 ± 50

Clutch Engagement (rpm): 2500 ± 200

DS 70 Models

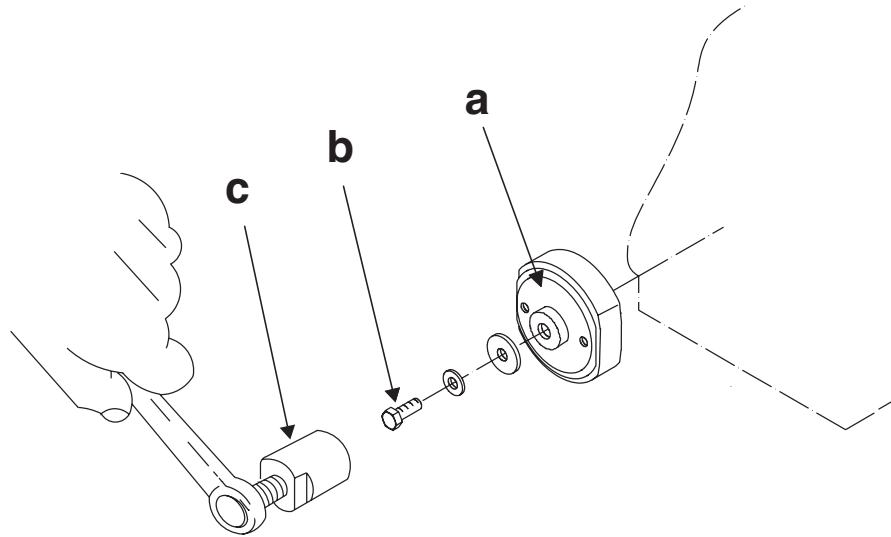

wc\_gr002372rm

## 5 Ramming System

### 5.1 Bellows

See Graphic: *wc\_gr001321rm*

#### Recommended Tools

Ratchet wrench  
Torque wrench  
Hex key or hex socket: 8 mm  
Socket: 13 mm  
Punch  
Rubber mallet  
Screwdriver  
Loctite 243

The bellows provides a flexible joint between the ramming system and the upper machinery. It seals the ramming system and provides a path for recirculating the oil. Periodically, tighten the clamps, clean the bellows, and inspect the bellows for signs of damage or leaks.

#### Removal

- 5.1.1 Drain the oil into a suitable container as described in section *Ramming System Lubrication*.
- 5.1.2 Remove the four socket head cap screws **(c)** that secure the ramming system to the crankcase.
- 5.1.3 Stand on the ramming shoe and pull up hard on the crankcase until the end plugs **(h)** are visible.
- 5.1.4 Drive out the end plugs and piston pin **(g)** holding the connecting rod to the ram. Do not reuse the end plugs.
- 5.1.5 Lift the upper machinery from the ramming system.
- 5.1.6 Remove the O-ring **(b)**; do not reuse.
- 5.1.7 To free the guide cylinder **(a)** from the bellows **(e)**, loosen the top bellows clamp **(d)**, stand on the ramming shoe, and pull up hard on the guide cylinder.
- 5.1.8 To free the bellows from the protective pipe **(j)**, loosen the bottom bellows clamp **(f)**, stand on the ramming shoe, pull on the bellows, and rap along the bottom of the bellows with a rubber mallet.

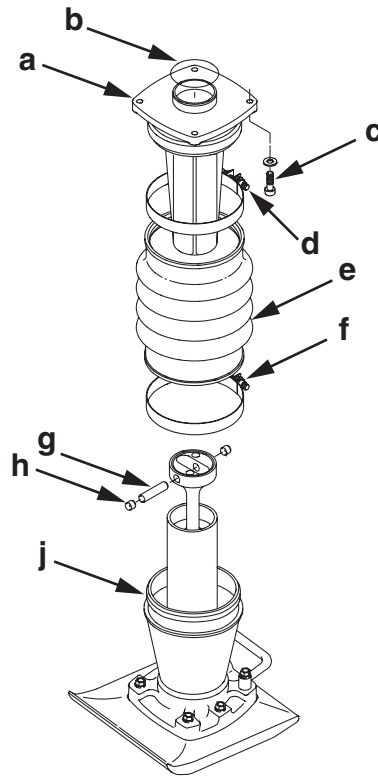

wc\_gr001321rm

## Installation

- 5.1.9 Oil the inner edges of the bellows.
- 5.1.10 Place the lower clamp (f) on the protective pipe (j).
- 5.1.11 Press the bellows (e) onto the protective pipe (j) with a strong downward push.
- 5.1.12 Partially tighten the clamp onto the bellows.
- 5.1.13 Place the upper clamp (d) on the bellows.
- 5.1.14 Press the guide cylinder (a) onto the bellows with a strong downward push.
- 5.1.15 Partially tighten the spring clamp onto the bellows.
- 5.1.16 Install a new O-ring (b).
- 5.1.17 Position the upper machinery over the guide cylinder.
- 5.1.18 Align the connecting rod inside the ram.
- 5.1.19 Install the piston pin (g) and new end plugs (h).

**Note:** Use new end plugs whenever the piston pin has been removed.

**Note:** To aid in installation, it may be necessary to gently heat the clamping area of the bellows with an electric heat gun.

- 5.1.20 Fasten the guide cylinder to the crankcase. Apply Loctite 243 and torque the screws to 43 Nm (32 ft.lbs.).
- 5.1.21 Lay the rammer flat on the ground and align the protective pipe with the upper machinery.
- 5.1.22 Position the clamps so that the clamp screws **(k)** are in line with the sightglass **(m)**.
- 5.1.23 Tighten the clamps and torque them to 13.5 Nm (10 ft.lbs.).
- 5.1.24 Fill the ramming system with clean oil as described in section *Ramming System Lubrication*.
- 5.1.25 Run the rammer for several minutes and check it for oil leaks around the guide cylinder and the bellows.

## 5.2 Replacing the Ramming Shoe

### Requirements

- Torque wrench
- Lifting device capable of lifting the machine

### Removal

Perform the procedure below to remove the shoe.

- 5.2.1 Support the machine with a lifting device capable of lifting the weight of the machine. See chapter *Technical Data* for weights.
- 5.2.2 On machines with cast iron shoes, remove the hex head screws (**a** and **b**) that hold the shoe (**c**) to the machine. For all others, remove the lock nuts (**d**) and washers (**e**) that hold the ramming shoe (**f**) and the bottom plate (**g**) to the machine.

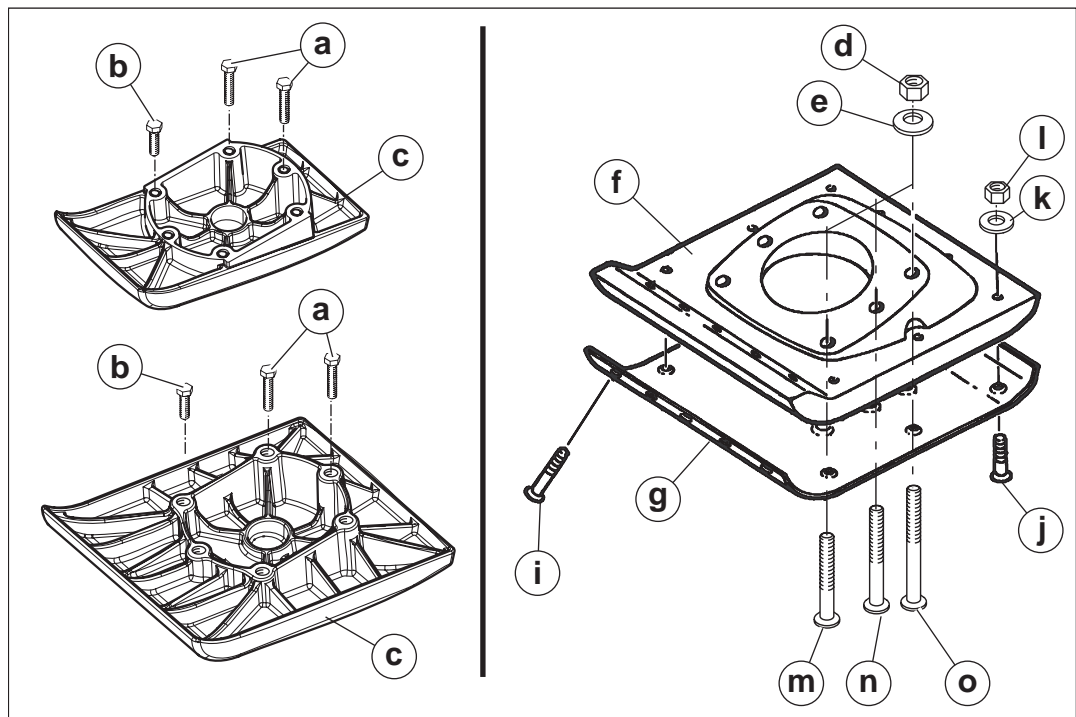

wc\_gr007519

- 5.2.3 Raise the machine off the shoe. Position the machine in a secure place.
- 5.2.4 Remove the plow bolts (**m**), (**n**), and (**o**).
- 5.2.5 Remove the plow bolts (**i** and **j**), lockwashers (**k**), and lock nuts (**l**).
- 5.2.6 Separate the shoe (**g**) from the bottom plate (**f**).

## Installation

Follow the guidelines below when installing the shoes.

- 5.2.7 The plow bolts (**m**, **n**, and **o**) and (**l** and **j**) as well as hex bolts (**a** and **b**) have different lengths. Use the longer of the bolts where needed.

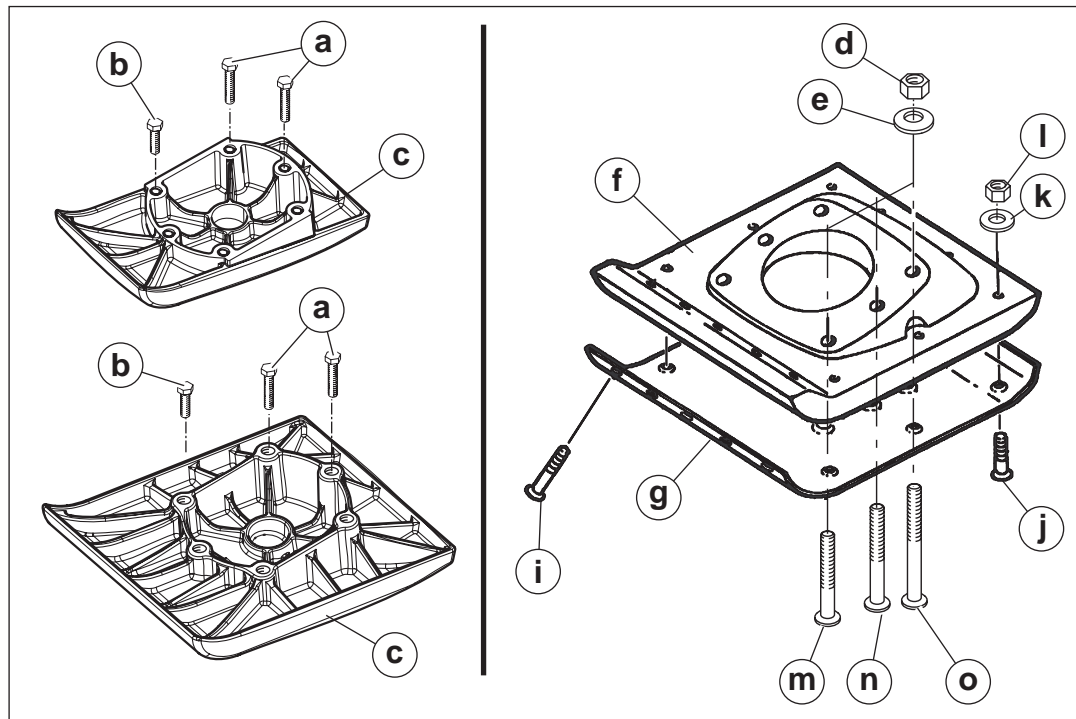

wc\_gr007519

- 5.2.8 When reusing bolts, clean the threads thoroughly before use.
- 5.2.9 Be sure notches of plow bolts seat in grooves of shoe.
- 5.2.10 Torques: (Recheck torques after first five hours of use.)
- hex bolt (**a**): 85.5 Nm (63 ft.lbs.)
  - lock nuts (**e**): 79 Nm (58 ft.lbs.)
  - lock nuts (**l**): 24 Nm (18 ft.lbs.)



Notes

### 5.3 Spring System Cover Removal and Installation

See Graphic: *wc\_gr001324rm*

#### Recommended Tools

Ratchet wrench  
Torque wrench  
Hex key or socket: 13 mm  
Hydraulic press or  
Two threaded rods and nuts: M8 x 120 mm or  
Spring box tool P/N 0081423  
Loctite 243



The spring system cover is under heavy pressure. It must be carefully removed and installed using either the hydraulic press, the threaded rod, or the spring box tool method. If the spring system cover is removed incorrectly, the springs can eject with enough force to cause serious injury or death!

#### Hydraulic Press Removal Method

- 5.3.1 Remove the ramming shoe per section *Ramming Shoe*. Separate the ramming system from the upper machinery per section *Bellows*.
- 5.3.2 Remove all but two of the socket head cap screws that hold the spring system cover to the spring cylinder.
- 5.3.3 Place the spring cylinder in a hydraulic press and position the head of the press in firm contact with the spring system cover.
- 5.3.4 Lock the press and remove the remaining two screws.
- 5.3.5 Slowly release the press and allow the springs to expand.
- 5.3.6 After all the spring pressure is released, remove the spring system cover, the gasket, and the bottom spring set.

#### Hydraulic Press Installation Method

- 5.3.7 Install the bottom spring set into the spring cylinder.
- 5.3.8 Place a new gasket onto the spring cylinder.
- 5.3.9 Center the spring cylinder, the springs, and the spring system cover under the hydraulic press ram.
- 5.3.10 Align the holes in the spring system cover as close as possible with the holes in the spring cylinder; dowels or steel rods can be placed in the holes to act as guides.
- 5.3.11 Compress the springs until the spring system cover rests on the spring cylinder.
- 5.3.12 Install the socket head cap screws. Apply Loctite 243 and torque the screws to 24 Nm (18 ft.lbs.).
- 5.3.13 Reinstall the ramming shoe.

5.3.14 Attach the ramming system to the upper machinery.

Hydraulic Press Method

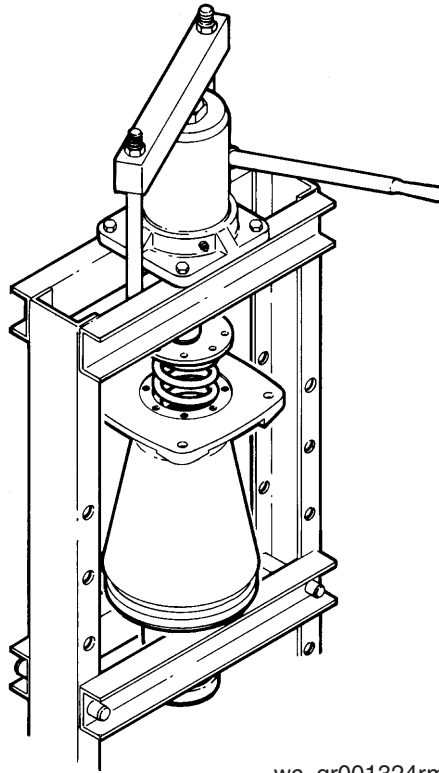

wc\_gr001324rm

See Graphic: wc\_gr001325rm

## Threaded Rod Removal Method

- 5.3.15 Remove the ramming shoe per section *Ramming Shoe*. Separate the ramming system from the upper machinery per section *Bellows*.
- 5.3.16 Remove the two socket head cap screws that are opposite of each other on the spring system cover.
- 5.3.17 Screw the two M8 x 120 threaded rods into the bottom of the spring cylinder until they bottom out.
- 5.3.18 Turn the nuts down each rod until they contact the spring system cover.
- 5.3.19 With the nuts holding the spring system cover, remove the remaining screws.
- 5.3.20 Evenly back off both nuts until the springs have fully expanded and the pressure is released.



Make sure the threaded rods are not turning out of the cylinder while backing off the nuts. The spring system cover is under heavy pressure. It must be carefully removed and installed using either the hydraulic press, the threaded rod, or the spring box tool method. If the spring system cover is removed incorrectly, the springs can eject with enough force to cause serious injury or death!

- 5.3.21 Remove the spring system cover, the gasket, and the bottom spring set.

## Threaded Rod Installation Method

- 5.3.22 Install the bottom spring set into the spring cylinder.
- 5.3.23 Place a new gasket onto the spring cylinder.
- 5.3.24 Insert the two threaded rods through the opposite sides of the spring system cover and screw them into the spring cylinder until they bottom out.
- 5.3.25 Compress the springs by evenly screwing the two nuts down the threaded rods until the spring system cover makes contact with the spring cylinder.
- 5.3.26 Install the socket head cap screws. Apply Loctite 243 and torque the screws to 24 Nm (18 ft.lbs.).
- 5.3.27 Reinstall the ramming shoe.
- 5.3.28 Attach the ramming system to the upper machinery.

Threaded Rod Method

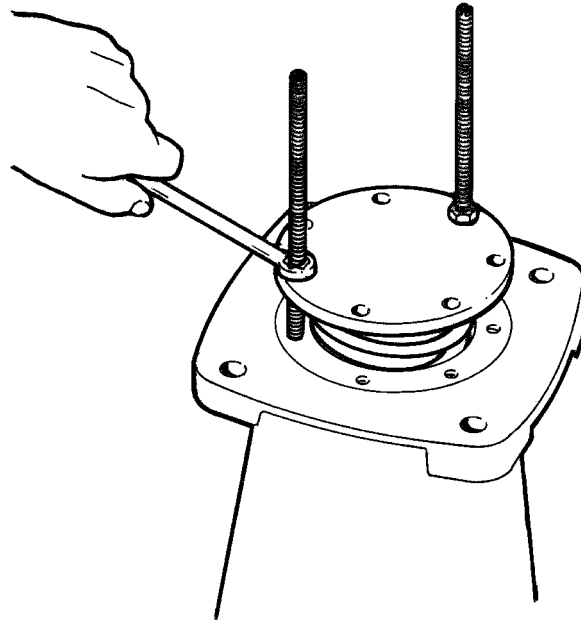

wc\_gr001325rm

See Graphic: wc\_gr001326

## Spring Box Tool Removal Method

- 5.3.1 Remove the ramming shoe per section *Ramming Shoe*. Separate the ramming system from the upper machinery per section *Bellows*.
- 5.3.2 Align three holes in the spring box tool **(a)** with three socket head cap screws in the spring system cover.
- 5.3.3 Remove the three socket head cap screws that align with the holes in the spring box tool.
- 5.3.4 Place the spring box tool on the spring system cover. Insert the three spring box screws **(c)** through the three selected holes in the spring box tool and turn the screws into the spring cylinder until they bottom out.
- 5.3.5 Turn the hex head cap screw **(b)** through the center of the spring box tool until the spring box tool reaches the top of the spring box screws.
- 5.3.6 With the spring box tool holding the spring system cover, remove the remaining spring system cover screws.
- 5.3.7 Back off the hex head cap screw until the springs have fully expanded and the pressure is released.



**WARNING**

The spring system cover is under heavy pressure. It must be carefully removed and installed using either the hydraulic press, the threaded rod, or the spring box tool method. If the spring system cover is removed incorrectly, the springs can eject with enough force to cause serious injury or death!

- 5.3.8 Remove the spring system cover, the gasket, and the bottom spring set.

## Spring Box Tool Installation Method

- 5.3.9 Install the bottom spring set into the spring cylinder.
- 5.3.10 Place a new gasket onto the spring cylinder.
- 5.3.11 Align three holes in the spring box tool with three holes in the spring system cover.
- 5.3.12 Insert the three spring box screws through the selected holes in the spring box tool and spring system cover.
- 5.3.13 Turn the spring box screws into the spring cylinder until they bottom out.
- 5.3.14 Turn the hex head cap screw through the center of the spring box tool until the spring system cover makes contact with the spring cylinder.
- 5.3.15 Install the socket head cap screws. Apply Loctite 243 and torque the screws to 24 Nm (18 ft.lbs.).
- 5.3.16 Reinstall the ramming shoe.
- 5.3.17 Attach the ramming system to the upper machinery.

## Spring Box Tool Method

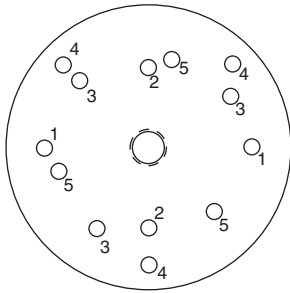

Screw Position Schraube position La posición del tornillo La position de vis	Qty st.	Machine
1	2	BS45Y, BS52Y, ES45Y, ES52Y
2	2	BS60Y, GVR151Y
3	3	BS62Y, BS65y, BS600, BS650, BS700, BS60-2i, BS70-2i, BS65V, BS60-4, DS72Y, DS720, DS70
4	3	BS92Y, BS105Y
5	3	BS500, BS50-2I, BS50-4

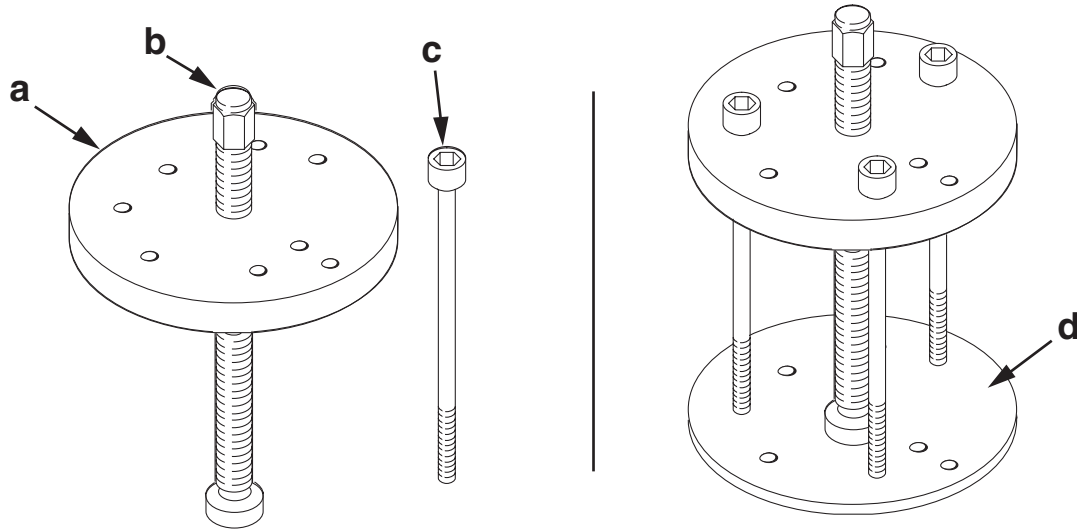

wc\_gr001326

## 5.4 Spring System

See Graphic: *wc\_gr001327rm, wc\_gr001328rm*

### Recommended Tools

Impact wrench  
 Socket: 32 mm or 24mm (BS 500 only) deep well  
 Drift pin  
 Torque wrench  
 Rubber mallet  
 Impact bushing puller P/N 0116816  
 Loctite 243 (blue)

### Disassembly

- 5.4.1 Remove the ramming shoe and separate the ramming system from the upper machinery.
- 5.4.2 Remove the spring system cover and the spring set per section *Spring System Cover Removal and Installation*.
- 5.4.3 Loosen the nut **(d)** on the impact bushing puller to allow the yoke **(c)** to set on the flange surface of the rammer and the jaws to reach the bottom of the impact bushing.
- 5.4.4 Push the jaws **(a)** of the impact bushing puller over the impact bushing **(b)** until it seats at the bottom of the impact bushing.
- 5.4.5 Tighten the nut on the impact bushing puller to remove the impact bushing as shown in the graphic and discard.
- 5.4.6 Place a drift pin through the holes on the end of the ram **(e)** to prevent the ram from turning.
- 5.4.7 Use an impact wrench to remove the locknut **(k)**.
- 5.4.8 Remove the piston guide **(j)**.
- 5.4.9 Remove the spring set **(g)** and the bushing **(f)** from the spring cylinder.

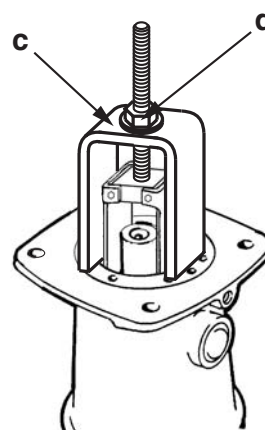
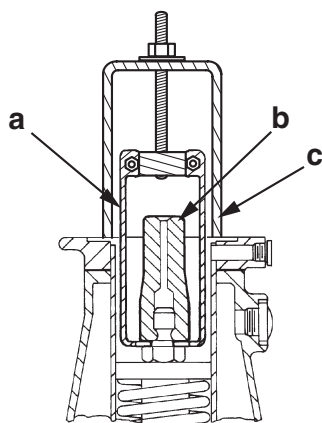

wc\_gr001327rm



## Assembly

- 5.4.10 Slide the ram (**e**) into the spring cylinder (**h**).
- 5.4.11 Reinstall the bushing (**f**) and the spring set (**g**).
- 5.4.12 Reinstall the piston guide (**j**).
- 5.4.13 Replace the locknut (**k**) and torque it to:  
 BS 500 - 210 Nm (155 ft.lbs.)  
 BS 600/700 - 250 Nm (184 ft.lbs.).
- 5.4.14 Press a new impact bushing (**m**) onto the end of the ram and seat it by hitting the end of the impact bushing with a rubber mallet.
- 5.4.15 Reinstall the spring set (**n**).
- 5.4.16 Install a new gasket (**o**).
- 5.4.17 Reinstall the spring system cover (**p**) using one of the three methods described in section *Spring System Cover Removal and Installation*. Apply Loctite 243 and torque the screws to 24 Nm (18 ft.lbs.).

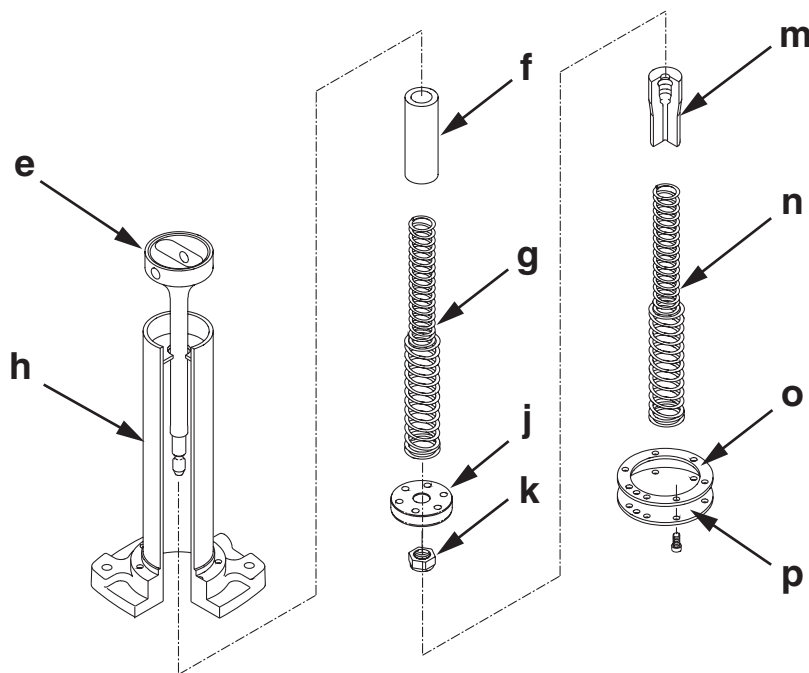

wc\_gr001328rm

5.5 Inspecting the Spring System

See Graphic: wc\_gr001329rm

Over time, the constant compression and release of the spring pressure can cause the springs to wear out. If the rammer feels to be hitting with less force, it is possible that the springs are worn and should be replaced.

A broken spring causes the rammer to jump erratically. This condition is more noticeable on hard soils. Do not run the rammer if a broken spring is suspected. Doing so may damage other rammer parts.

Replace both the top and the bottom spring sets even if only one set is worn or damaged.

- 5.5.1 Remove the springs from the cylinder and check them for minimum spring free height and maximum spring height difference per the table below. Replace the springs if they do not meet the given specifications.
- 5.5.2 If a spring has broken, inspect the inside of the spring cylinder wall for burrs, gouges, and cracks as follows:
  - Slide the piston guide inside the cylinder. Check that the piston guide moves freely but without excessive side play.
  - Hone the cylinder to remove the ridges and the burrs that were cut into the cylinder wall by the spring movement.
  - Replace the cylinder if it is badly worn.

	Minimum spring free height (a)	Maximum spring height difference (b)
BS 500, BS 50	194 mm (7 21/32 in.)	5 mm (3/16 in.)
BS 600, BS 60 BS 700, BS 70 BS 650, BS 65V DS 720, DS 70	217 mm (8 9/16 in.)	5 mm (3/16 in.)

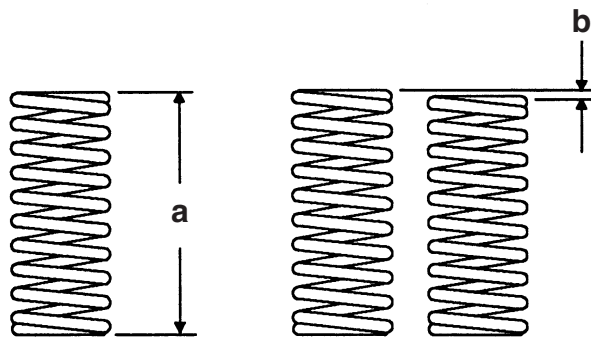

wc\_gr001329rm

## 5.6 Protective Pipe

See Graphic: *wc\_gr001330rm*

### Recommended Tools

Ratchet Wrench  
 Torque Wrench  
 Extension  
 Hex Socket: 6 mm  
 Loctite 243 (Blue)

If the protective pipe becomes loose or damaged, it must be replaced on the spring cylinder.

- 5.6.1 Remove the bellows following the procedures in section *Bellows*.
- 5.6.2 Remove the socket head cap screws **(c)**. To reinstall the protective pipe, apply Loctite 243 and torque the screws to 24 Nm (18 ft.lbs.).
- 5.6.3 Reassemble the rammer following the previous procedures.

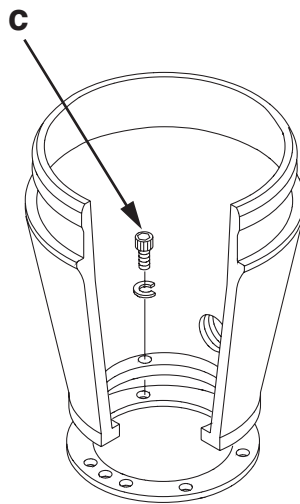

wc\_gr001330rm

## 5.7 Ramming System Lubrication (BS 500/600/700/650, DS 720)

See Graphic: *wc\_gr001331rm*

### Recommended Tools

Hex Key: 8 mm  
Ratchet Wrench  
Torque Wrench  
Extension  
Sockets: 19 mm (3/4"), 27 mm (1 1/16")  
Teflon Tape

Oil for lubrication is carried throughout the ramming system by the action of the rammer. Holes drilled in the piston allow the oil to be distributed from the bottom of the rammer to the crankcase. Oil in the ramming system must be maintained at the correct level to ensure the system operates efficiently.

### Check oil level:

Check the oil level in the sightglass **(a)** daily before starting the rammer. When checking the oil, make sure the rammer is on a flat, level surface. The oil level should fill 1/2–3/4 of the sightglass. Add the oil through the fill plug **(c)** located in the filter housing at the top of the rammer. See section *Technical Data* for oil quantity and type.

Change the ramming system oil after the first 50 hours of operation and then after every 300 hours of use.

### Oil change:

- 5.7.1 Remove the oil fill plug **(c)** and the seal ring.
- 5.7.2 BS 500: Remove the sightglass.  
BS 600/700/650, DS720: Remove the drain plug **(b)**.
- 5.7.3 Tilt the rammer back until it is resting on its handle.
- 5.7.4 Allow the oil to drain.
- 5.7.5 Wrap the sightglass threads with Teflon tape.
- 5.7.6 Reinstall the sightglass or the drain plug, and torque to 9.5 Nm (7 ft.lbs.).
- 5.7.7 Stand the rammer upright on a level surface.
- 5.7.8 Add oil through the fill plug. Proper ramming system lubrication is indicated when approximately 1/2–3/4 of the sightglass is full.

**NOTICE:** It may take some time for the oil to filter down to the sightglass. Use care not to overfill the ramming system. Excessively high levels of oil can create a hydraulic lock in the ramming system. This can result in erratic operation and cause damage to the engine clutch, the ramming system, and the shoe.

5.7.9 Reinstall the seal-ring and the fill plug. Torque the fill plug to 47 Nm (35 ft.lbs.).

**Note:** An alternate method of changing the oil is to drain and fill the oil from the sightglass.

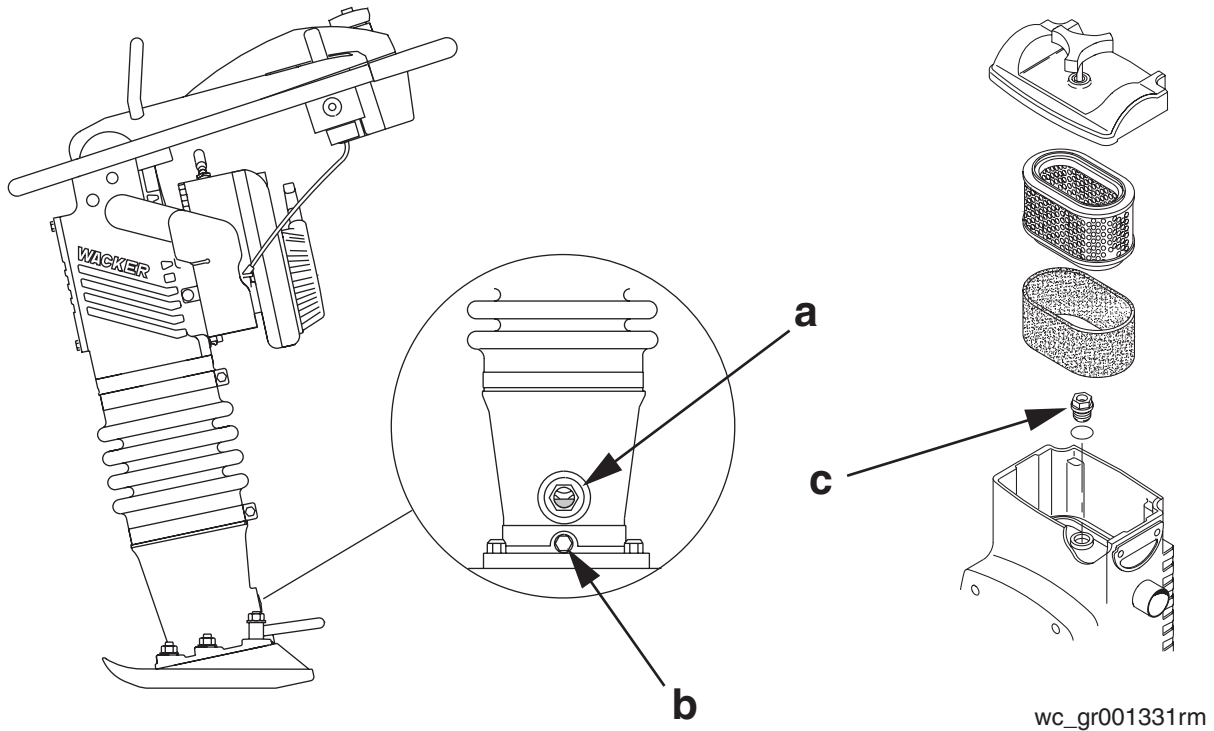

## 5.8 Ramming System Lubrication (BS 50/60/70, BS 65, DS 70)

### Background

Lubricating oil is distributed throughout the ramming system by the action of the rammer. Holes drilled in the piston carry oil from the bottom of the rammer to the crankcase as the rammer operates. Oil in the ramming system must be maintained at the correct level to ensure the ramming system operates efficiently.

### Checking the oil level

Perform the following procedure to check the ramming system oil level.

**Note:** If the Rammer has been transported in the horizontal position or has recently been used, upright it and allow it to stand in the upright position for 15 minutes before checking the oil level. This will allow the oil to settle and provide for a more accurate reading.

#### 5.8.1 Tip the rammer so that it is perpendicular with the ground.

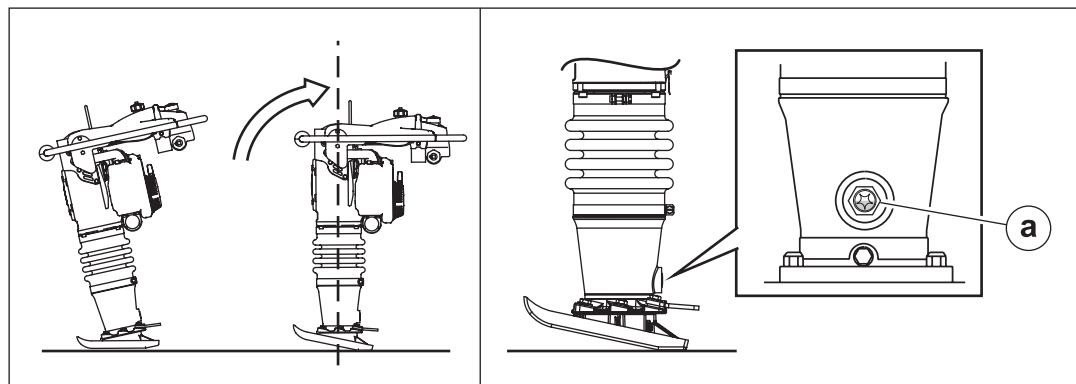

wc\_gr007389

#### 5.8.2 Check the oil through the sightglass (a).

The correct oil level will fill 1/2 to 3/4 of the sightglass. Add more oil if need be.

### Adding oil

Perform the following procedure to add oil to the ramming system.

**NOTICE:** Do not to overfill the ramming system with oil. Excessively high levels of oil can create a hydraulic lock in the ramming system. This can result in erratic operation and cause damage to the engine clutch, the ramming system, and the shoe.

#### 5.8.3 Tip the Rammer forward to allow access to the sightglass. Secure the Rammer in this position.

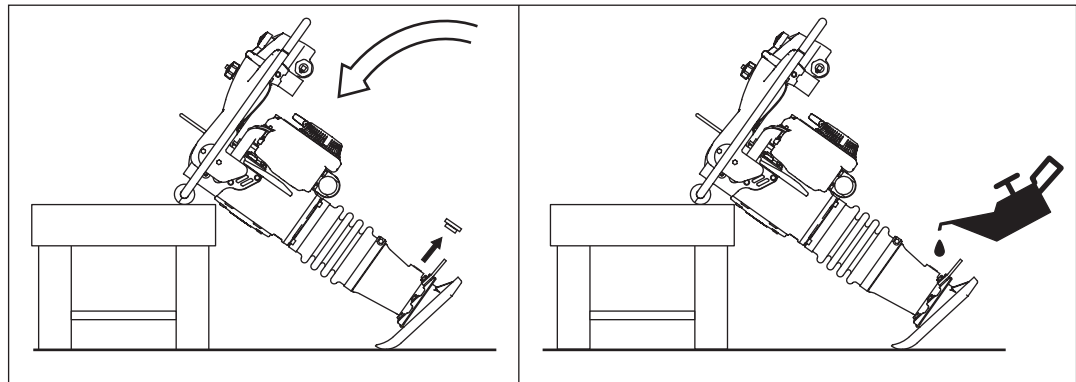

wc\_gr007401

- 5.8.4 Remove the sightglass. Clean the threads of the sightglass, then wrap the threads with Teflon tape.
- 5.8.5 Add oil to the machine through the sightglass opening in the housing.
- 5.8.6 Stand the machine upright to check the oil level. Add enough oil so that when the machine is upright, oil will fill 1/2 to 3/4 of the sightglass. At that point, install the sightglass. Torque the sightglass to 9 Nm (6 ft.lbs.).

## Changing oil

Perform the following procedure to change the ramming system oil.

**Note:** Dispose of used oil in accordance with local environmental regulations.

- 5.8.7 Remove the drain plug (b). (On BS 50 machines, remove the sightglass (a).)

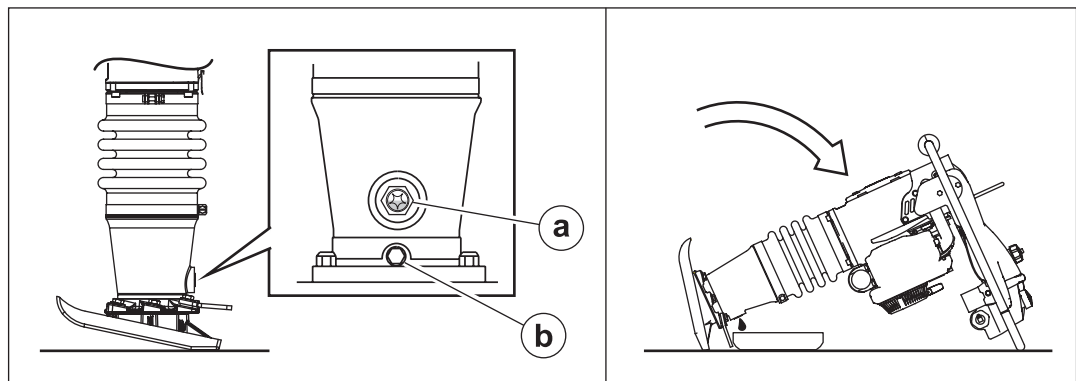

wc\_gr007410

- 5.8.8 Tilt the rammer backward until it is resting on the handle and drain the oil into a suitable container.  
**Note:** It may take up to 10 minutes for the oil to drain.
- 5.8.9 Reinstall the drain plug. Torque it to 54 Nm (40 ft.lbs.).
- 5.8.10 Add oil as stated above.

## 6 Crankcase

### 6.1 Crank Gear and Connecting Rod

See Graphic: *wc\_gr007520*

#### Recommended Tools

Hex key: 8 mm  
2-Jaw bearing puller  
Large diameter retaining-ring pliers  
Hydraulic press  
Screwdriver  
Split puller  
Slide hammer  
Torque wrench  
Loctite® 243 (blue)

#### Removal

- 6.1.1 Remove the four socket head cap screws that secure the ramming system to the crankcase.
- 6.1.2 Stand on the ramming shoe and pull up hard on the crankcase until the pin holding the connecting rod to the ram is visible.
- 6.1.3 Drive out the end plugs and the piston pin.
- 6.1.4 Lift the upper machinery from the ramming system.
- 6.1.5 Remove the four socket head cap screws **(a)** from the front cover.
- 6.1.6 Insert a screwdriver into the slots on each side of the cover and pry off the cover. The cover will come out with the crank gear **(g)** and the connecting rod **(k)** attached.  
**Note:** *The crankcase cover cannot be removed until the connecting rod is detached from the ram.*
- 6.1.7 Reach through the slotted hole **(m)** in the crank gear and release the large retaining ring **(f)**.
- 6.1.8 Thread two M8 socket head cap screws, or threaded rods, through the pusher holes **(n)** in the crank gear. Turn the screws into the crank gear to free the crank gear and the bearing from the cover.
- 6.1.9 Remove the small retaining ring **(d)** securing the bearing **(e)** to the crank gear.
- 6.1.10 Pull the bearing free of the shaft using the split puller **(p)** and a 2-jaw bearing puller **(o)**.
- 6.1.11 Remove the small retaining ring **(h)** that holds the connecting rod and the bearing **(j)** to the crank gear.
- 6.1.12 Pull the connecting rod off the crank gear with a 2-jaw bearing puller.
- 6.1.13 Press the bearing out of the connecting rod.



- 6.1.14 The needle bearing (**c**) remains intact in the crankcase cover. Inspect the needle bearing for wear and, if damaged, remove it by using a slide hammer or similar pulling device.

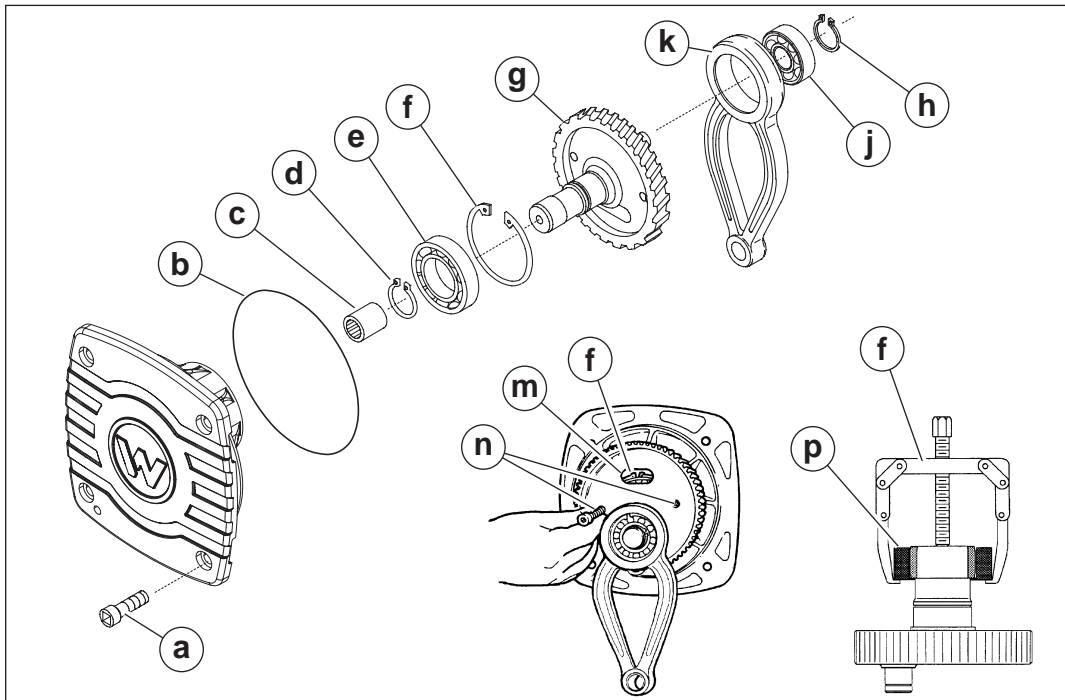

wc\_gr007520

## Assembly

- 6.1.15 If the needle bearing was removed, press a new bearing into the cover until the outer race is flush with the flange surface.
- 6.1.16 Place the large retaining ring over the crank gear shaft.
- 6.1.17 Press the ball bearing onto the crank gear shaft and reinstall the small retaining ring.
- 6.1.18 Press the connecting rod assembly onto the crank gear and secure it in place with the small retaining ring.
- 6.1.19 Push the complete crank gear assembly into the bearing housing and seat the retaining ring in the groove.
- 6.1.20 Replace the o-ring (**b**).
- 6.1.21 Assemble the cover to the crankcase. Torque the screws to 49 Nm (36 ft.lbs.).
- 6.1.22 Connect the crankcase to the ramming system as follows:
- Position the upper machinery over the guide cylinder.
  - Align the connecting rod inside the ram.
  - Install the piston pin and the end plugs.
- Note:** Use new end plugs whenever the piston pin has been removed.
- Fasten the guide cylinder to the crankcase. Apply Loctite 243 and torque the screws to 43 Nm (32 ft.lbs.).

**6.2 Crank Gear, Connecting Rod, and Adjuster Assembly (BS 650/65 only)**

See Graphic: *wc\_gr001334rm*

**Recommended tools**

Hex key: 8 mm  
2-Jaw bearing puller  
Large diameter retaining-ring pliers  
Hydraulic press  
Screwdrivers or pry bars  
Split puller  
Slide hammer  
Punch  
Torque wrench  
Loctite 243 (blue)

**Removal**

- 6.2.1 Remove the four socket head cap screws that secure the ramming system to the crankcase.
- 6.2.2 Stand on the ramming shoe and pull up hard on the crankcase until the pin holding the connecting rod to the ram is visible.
- 6.2.3 Drive out the end plugs and the piston pin.
- 6.2.4 Lift the upper machinery from the ramming system.
- 6.2.5 Open the front cover and remove the four socket head cap screws **(31)** from the bearing mount **(16)**.
- 6.2.6 Insert a screwdriver on each side of the bearing mount and pry it off. The bearing mount and cover will come out with the crank gear **(20)** and the connecting rod **(24)** attached.  
**Note:** *The bearing mount and cover cannot be removed until the connecting rod is detached from the ram.*
- 6.2.7 Remove the snap ring **(25)**, then pry off the connecting rod assembly **(24)** with two pry bars.
- 6.2.8 Press the ball bearing **(27)** out of the connecting rod.
- 6.2.9 Turn the assembly over and open up the crankcase cover.
- 6.2.10 Remove the two retaining rings **(3)** and drive the pin **(13)** out of the yoke **(4)** with a hammer and punch.
- 6.2.11 Remove the screws **(12)** and clamping ring **(5)**, then slide out the adjusting plate **(6)** and two Belleville spring washers **(7)**. The eccentric drive shaft **(23)**, pin **(28)**, and spring **(29)** will also slide out. Pull out the O-ring **(21)**.
- 6.2.12 Remove the small retaining ring **(9)** and press the crank gear **(20)** from the bearing mount.

6.2.13 The crankgear needle bearing (19), oil seal (11), and ball bearing (10) remain intact in the bearing mount.

- Examine the needle bearings for wear.
- If damaged, replace the needle bearings by removing the large retaining ring (8) holding the ball bearing to the bearing mount and press out the needle bearings and seal.
- Replace the needle bearings and oil seal together.

6.2.14 Remove the O-ring (18) and discard it.

6.2.15 The clutch drum needle bearing (17) will remain intact in the bearing mount. Inspect it for wear and if damaged, remove and replace it.

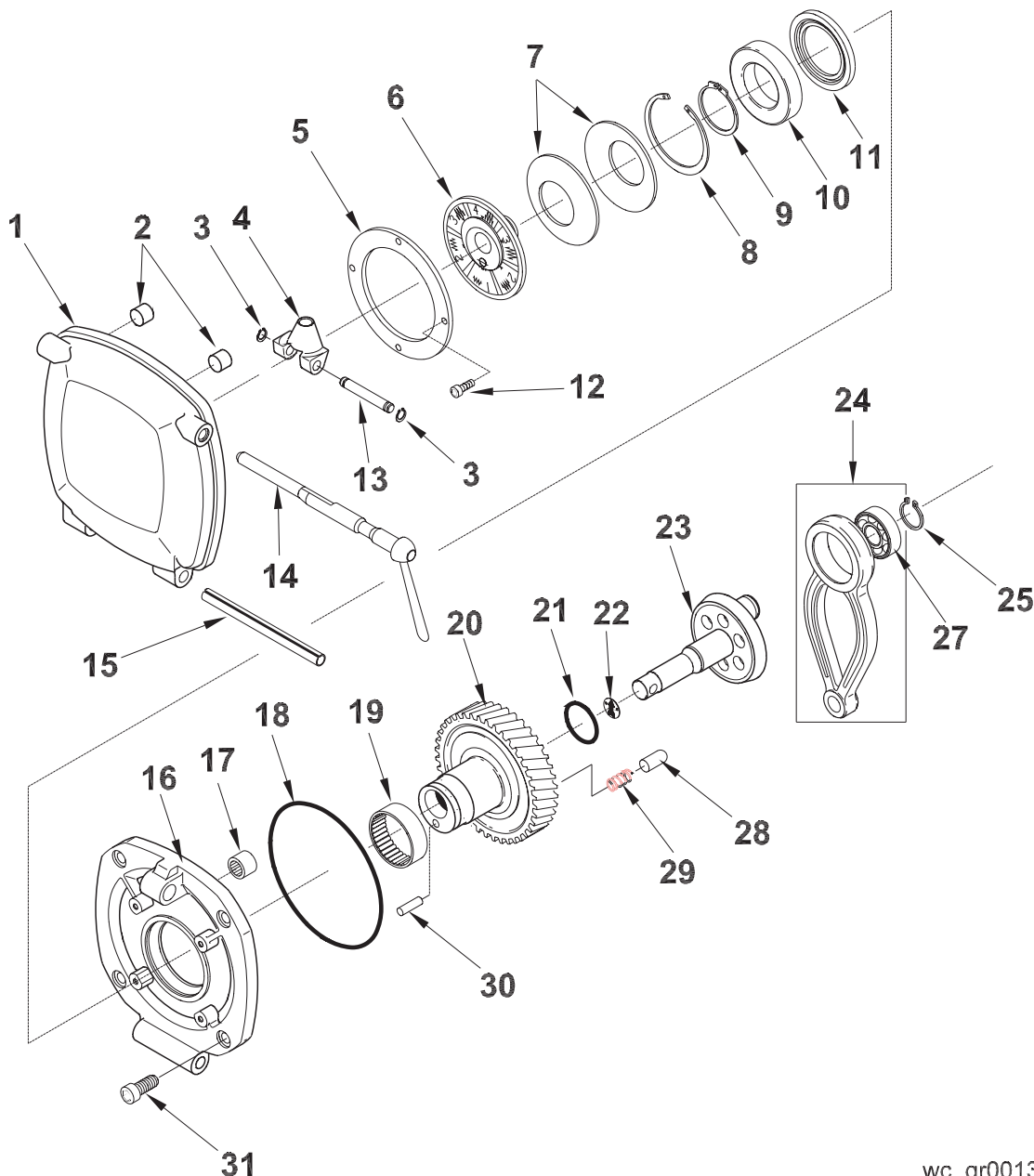

wc\_gr001334rm

**Assembly**

- 6.2.16 If the needle bearing **(17)** was removed, apply Loctite 609 to a new needle bearing and press it into the bearing mount until the outer race is flush with the flange surface.
- 6.2.17 Press the ball bearing **(27)** into the connecting rod.
- 6.2.18 Press the connecting rod assembly **(24)** onto the eccentric drive shaft **(23)** and secure it in place with the small snap ring **(25)**.
- 6.2.19 Press the crank gear **(20)** into the bearing mount **(16)** and secure it with the small retaining ring **(9)**.

**Note:** *If the small pin **(30)** was removed, replace it leaving a ½-inch showing. **DO NOT** bottom the pin in the hole.*

- 6.2.20 Grease O-ring **(21)** thoroughly and insert it into the crank gear.
- 6.2.21 Ensure the arrow label **(22)** is in place, then slide the eccentric drive shaft **(23)** and the spring **(29)** and pin **(28)** into the crank gear.
- 6.2.22 Place the two Belville spring washers **(7)** onto the eccentric drive shaft so that the outer edges are facing each other.
- 6.2.23 Place the adjusting plate **(6)** over the Belville spring washers, lining up pin **(30)** at position 1.
- 6.2.24 Place the clamping ring **(5)** over the adjusting plate. Apply Loctite 243 to the screws **(12)** and torque to 9.5 Nm (7 ft.lbs.). Tighten the screws evenly to compress the Belville spring washers.
- 6.2.25 Fit the yoke **(4)** over the eccentric drive shaft **(23)** and secure in place with pin **(13)**. Secure the pin with the two retaining rings **(3)**.

**Note:** *Install with the lever open and spring tension relaxed. When **CLOSED**, the lever should point in the same direction as the arrow.*

- 6.2.26 Insert a new O-ring **(18)**.
- 6.2.27 Push the complete crank gear assembly into the bearing housing and seat the retaining ring in the groove.
- 6.2.28 Assemble the bearing mount to the crankcase. Apply Loctite 243 and torque the screws **(31)** to 49 Nm (36 ft.lbs.).
- 6.2.29 Connect the crankcase to the ramming system as follows:
  - a. Position the upper machinery over the guide cylinder.
  - b. Align the connecting rod inside the ram.
  - c. Install the piston pin and the end plugs.

**Note:** *Use new end plugs whenever the piston pin has been removed.*

- d. Fasten the guide cylinder to the crankcase. Apply Loctite 243 and torque the screws to 43 Nm (32 ft.lbs.).

**Notes**

### 6.3 Clutch Drum

See Graphic: *wc\_gr001335rm*

#### Recommended Tools

Hex Key: 8 mm  
Large diameter retaining-ring pliers  
Hydraulic press  
Screwdriver  
Slide hammer  
Torque wrench  
Loctite 243 (blue)  
Shell Alvania RL2

#### Removal

- 6.3.1 Remove the four socket head cap screws that secure the ramming system to the crankcase.
- 6.3.2 Stand on the ramming shoe and pull up hard on the crankcase until the pin holding the connecting rod to the ram is visible.
- 6.3.3 Drive out the end plugs and the piston pin.
- 6.3.4 Lift the upper machinery from the ramming system.
- 6.3.5 Remove the engine.
- 6.3.6 Remove the four socket head cap screws from the front cover.
- 6.3.7 Insert a screwdriver into the slots on each side of the cover and pry off the cover. The cover will come out with the crank gear and the connecting rod attached.  
**Note:** *The crankcase cover cannot be removed until the connecting rod is detached from the ram.*
- 6.3.8 Remove the small retaining ring **(b)** from the clutch drum shaft **(f)** inside the crankcase.
- 6.3.9 Press the clutch drum free of the crankcase.
- 6.3.10 Remove the shaft seal **(e)**.
- 6.3.11 Remove the large retaining ring **(d)**.
- 6.3.12 Press the clutch drum bearing **(c)** from the crankcase.
- 6.3.13 The needle bearing **(a)** remains intact in the crankcase cover. Inspect the needle bearing for wear and, if damaged, remove it by using a slide hammer or similar pulling device.

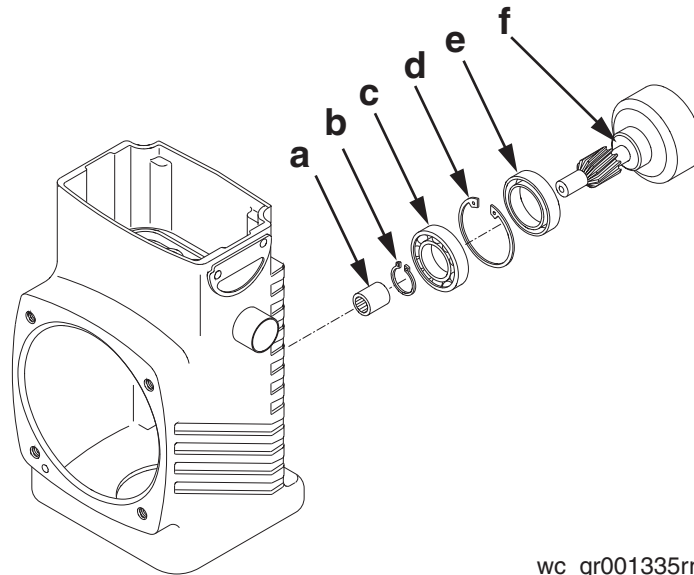

wc\_gr001335rm

## Assembly

- 6.3.14 If the needle bearing was removed, press a new bearing into the cover until the outer race is flush with the flange surface.

**NOTICE:** Keep the inside of the clutch drum absolutely free of any oil and grease.

- 6.3.15 Press the clutch drum ball bearing into the crankcase.
- 6.3.16 Secure the bearing with the large retaining ring.
- 6.3.17 Pack the shaft seal cavity with Shell Alvania RL2 grease. Install the shaft seal with the open side facing toward the bearing.
- 6.3.18 Press the clutch drum into the crankcase.
- 6.3.19 Secure the clutch drum with the small retaining ring.
- 6.3.20 Assemble the cover to the crankcase. Apply Loctite 243 and torque the screws to 49 Nm (36 ft.lbs.).
- 6.3.21 Connect the crankcase to the ramming system as follows:

- a. Position the upper machinery over the guide cylinder.
- b. Align the connecting rod inside the ram.
- c. Install the piston pin and the end plugs.

**Note:** Use new end plugs whenever the piston pin has been removed.

- d. Fasten the guide cylinder to the crankcase. Apply Loctite 243 and torque the screws to 43 Nm (32 ft.lbs.).

## 7 Oil Injection (if equipped)

### 7.1 Testing the Float Switch (2010 and later models)

#### Background

The function of the float switch is to prevent the engine from running without oil in the oil tank. If the oil tank is low on oil, the float switch opens and kills the ignition. A severed float switch wire will also kill the ignition. In the event that the engine runs but shuts off by itself within approximately 25 seconds, even with oil in the oil tank, the float switch could be faulty.

#### Requirements

- Machine shut down and cool
- Multimeter
- Oil tank at least 1/4 full

#### Procedure

Perform the procedure below to test the float switch.

##### 7.1.1 Remove the carburetor guard (a).

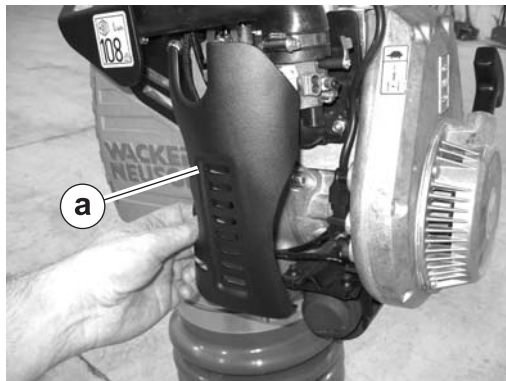

wc\_gr007416

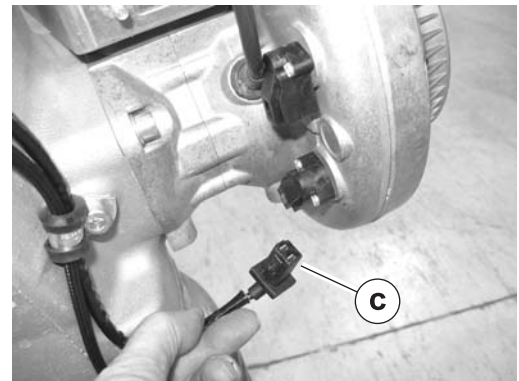

wc\_gr007451

##### 7.1.2 Disconnect the float switch wiring (c).



- 7.1.3 Check the continuity of the float switch by measuring across the connector.

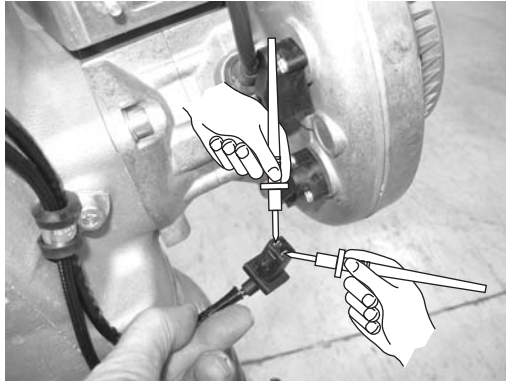

wc\_gr007546

*Does the float switch have continuity?*

Yes _____	No _____
The float switch is OK.	The float switch has failed; replace it.

- 7.1.4 Reconnect the float switch.
- 7.1.5 Reinstall the carburetor guard.

## 7.2 Replacing the Float Switch (2010 and later models)

### Requirements

- New float switch
- 2-cycle engine oil

### Removal

Perform the procedure below to remove the float switch.

7.2.1 Remove the silencing cover. See topic *Removing the Silencing Cover*.

7.2.2 Remove the carburetor guard (a).



wc\_gr007416

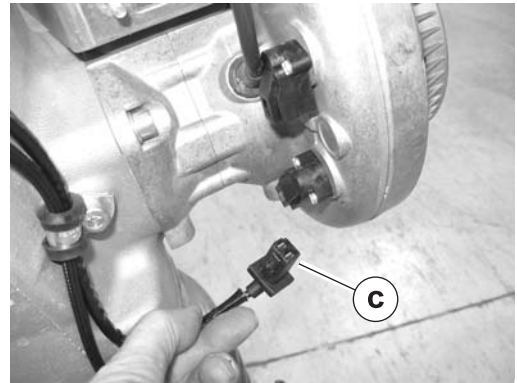

wc\_gr007451

7.2.3 Disconnect the float switch wiring (c).

7.2.4 Locate the oil tank (d).

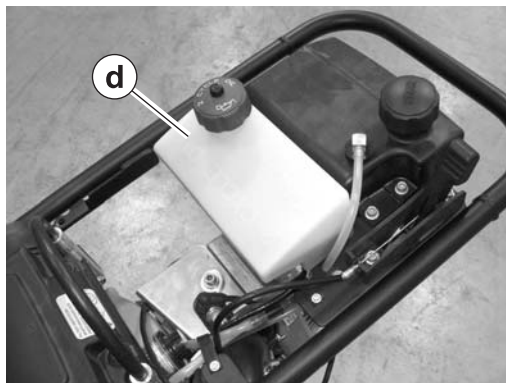

wc\_gr007547

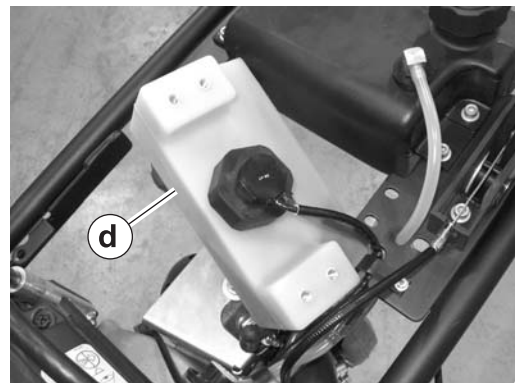

wc\_gr007548

7.2.5 Remove the screws that hold the oil tank and turn it upside down.

*This procedure continues on the next page.*

*Continued from the previous page.*

- 7.2.6 Unscrew the float switch assembly (e) from the oil tank.

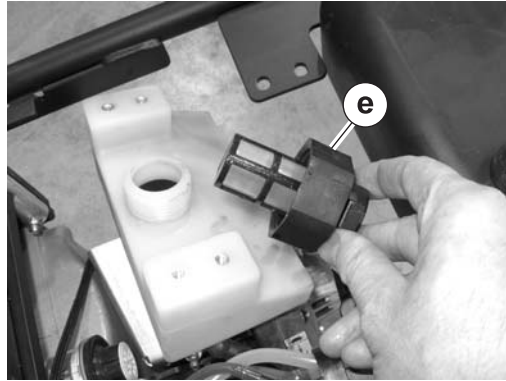

wc\_gr007549

- 7.2.7 Remove the float switch and wiring from the machine.

### Installation

Perform the procedure below to install the float switch.

- 7.2.1 Screw the new float switch assembly into the oil tank.  
7.2.2 Thread the wiring through the machine to the engine.  
7.2.3 Reinstall the oil tank. Torque screws to 9 Nm (6 ft.lbs.).  
7.2.4 Reinstall the silencing cover.  
7.2.5 Connect the wiring to the engine.  
7.2.6 Reinstall the carburetor guard. Torque screws to 23 Nm (16 ft.lbs.).

### Result

The replacement procedure is now complete.

### 7.3 Float Switch Testing and Replacement (pre-2010 models)

See Graphic: *wc\_gr001526*

**NOTICE:** Do not bypass the float switch except during testing; engine failure may occur.

The function of the float switch is to prevent the engine from running without oil in the oil tank. If the oil tank is low on oil, the float switch opens and kills the ignition. A severed float switch wire will also kill the ignition.

In the event that the engine runs but shuts off by itself within approximately 25 seconds, even with oil in the oil tank, the float switch could be faulty.

To test the float switch **(a)**:

- 7.3.1 Remove the carburetor guard **(d)**.
- 7.3.2 Inspect the float switch wire for damage.
  - If damage is present, replace the float switch.
  - If no damage to the float switch wire is obvious and the connector is fully seated at the engine **(b)**, continue.
- 7.3.3 Unplug the float switch wire from the engine.
- 7.3.4 Insert a jumper wire into the terminal on the engine to connect the two terminal leads.
- 7.3.5 Start the engine and run it at idle.
  - If the engine continues to run for more than 45 seconds, the float switch is faulty and must be replaced.
  - If the engine still shuts off within 25 seconds, the ignition module has failed and must be replaced.

To replace the float switch:

- 7.3.6 Drain the remaining oil from the oil tank or position the rammer so that the oil in the tank will not run out when the float switch is removed.
- 7.3.7 Remove the oil line from the float switch.
- 7.3.8 Disconnect the float switch from the back of the engine.
- 7.3.9 Unscrew the float switch assembly from the oil tank.
- 7.3.10 Screw a new float switch assembly into the oil tank.
- 7.3.11 Install the oil line to the float switch. Ensure that the oil line from the oil tank is routed through the coiled portion **(c)** of the float switch wire near the switch.
- 7.3.12 Ensure that the float switch plug is fully seated in the connector on the back of the engine.

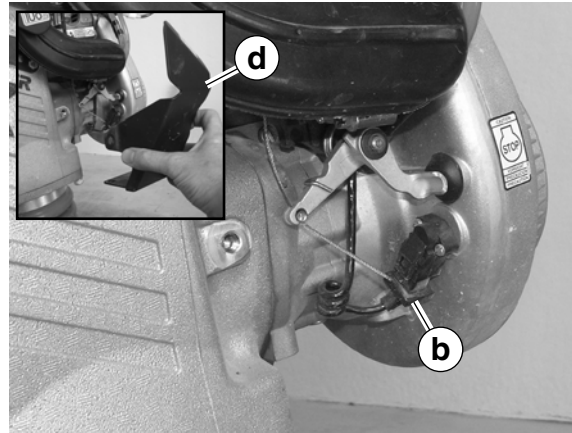
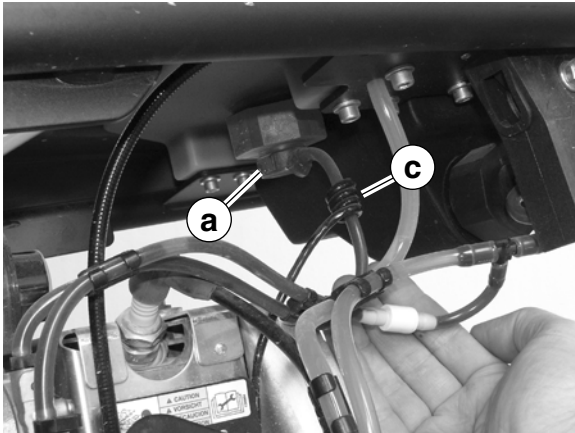

wc\_gr001526

## 7.4 Oil Line Check Valve

See Graphic: *wc\_gr001527*

The the function of the oil line check valve **(a)** is to prevent raw fuel from backing up to the oil pump. It is important that the check valve be installed in the correct direction. Looking at the side of the check valve, one should notice recessed areas with pointed ends or an arrow **(b)**. The pointed ends or the arrow must point towards the fuel line. This is the direction of oil flow.

To test the check valve:

The oil line check valve is spring operated and is designed to release at 1.5 psi. **Note:** *Initial release can be as high as 4.5 psi.*

7.4.1 Remove the oil line check valve from the oil line.

7.4.2 Attach a hand-operated vacuum pump to the outlet side (pointed end) of the oil line check valve and operate the vacuum pump until the vacuum overcomes the oil line check valve spring. Measure how much vacuum it takes to operate the oil line check valve. A vacuum reading of more than 2 psi (after initial release) is grounds for replacing the oil line check valve.

**Note:** *The oil line check valve is only available by replacing the entire hose assembly.*

Newly installed oil line check valves (and those that have lost their prime) require priming. There are two methods of priming the oil line check valve line with oil.

**Vacuum method:**

7.4.3 Attach a hand-operated vacuum pump to the fuel line end of the oil hose.

7.4.4 Place the oil pump side of the hose in a container of 2-cycle oil.

7.4.5 Operate the vacuum pump until the oil reaches the vacuum pump.

7.4.6 Install the oil line to the oil pump and to the fuel line.

**Pressure method:**

7.4.7 Attach a syringe filled with 2-cycle oil to the oil pump end of the hose.

7.4.8 Inject the oil into the hose until it passes through the oil line check valve.

7.4.9 Attach the oil line to the oil pump.

**NOTICE:** The oil line check valve is an important part of the oil injection system and should not be bypassed. Engine failure may occur.

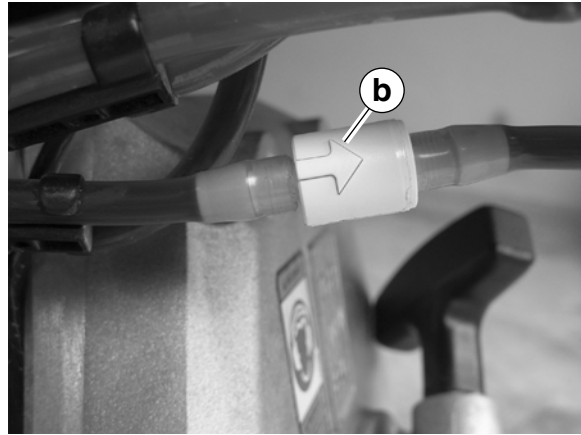
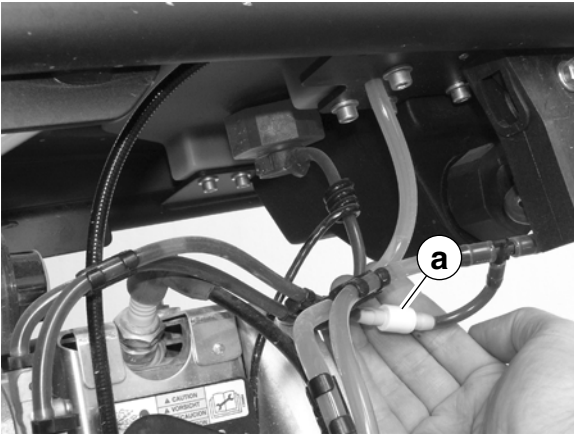

wc\_gr001527

## 7.5 Testing/Replacing the Oil Pump

### Background

Oil-injection Rammers can run up to 65 hours on one tank of oil. If the Rammer has been used for a long period of time, and it does not appear to have used any oil and the oil line check valve is operating correctly, remove and check the oil pump.

### Requirements

- Carburetor removed
- Engine removed
- Oil tank at least 1/4 full

### Removal and testing

Perform the procedure below to check the oil pump.

- 7.5.1 Remove the carburetor. See topic *Removing the Carburetor*.
- 7.5.2 Remove the engine. See topic *Removing the Engine*.
- 7.5.3 Remove the output hose (a) from the oil pump. **Do not remove the input hose.**

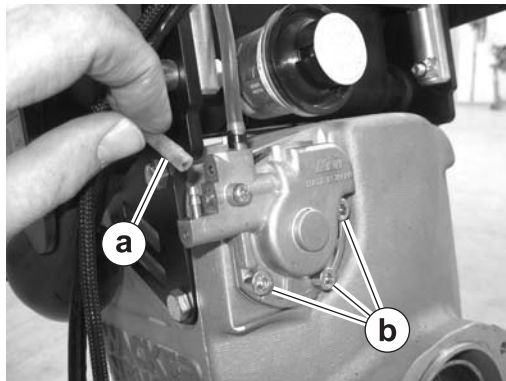

wc\_gr007550

- 7.5.4 Remove the three screws (b) that hold the pump assembly to the engine.

*This procedure continues on the next page.*



*Continued from the previous page.*

- 7.5.5 Separate the pump from the cartridge portion of the pump assembly. The cartridge may remain in the engine.

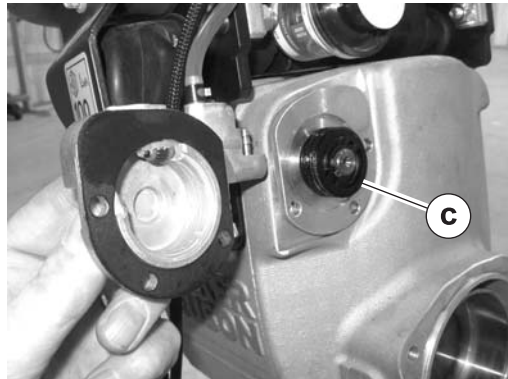

wc\_gr007551

- 7.5.6 Inspect the gear (c) for damage. If the gear is damaged, replace it.

- 7.5.7 Open the bleed screw (d) until oil flows from the output nipple (e), then close the bleed screw.

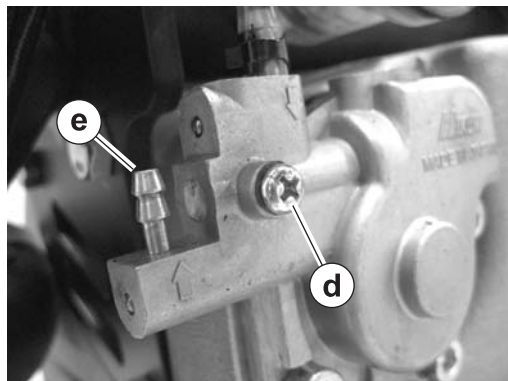

wc\_gr007552

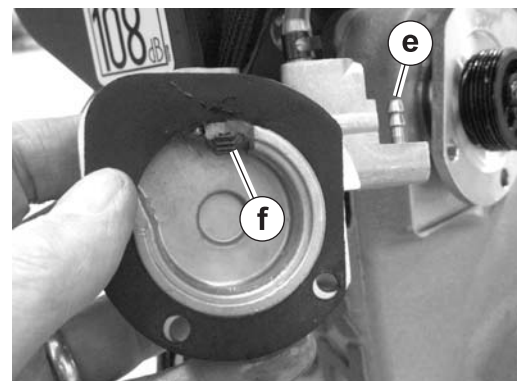

wc\_gr007553

- 7.5.8 Rotate the small gear (f) within the pump housing. Oil should flow out of the output nipple (e) within 20 revolutions of the small gear. If no oil flows out of the output nipple, replace the pump.

**Note:** The pump puts out a 0.8 mm (0.030 in.) droplet of oil every 7–9 seconds of running at 4350 rpm.

*This procedure continues on the next page.*

*Continued from the previous page.*

- 7.5.9 Remove the cartridge assembly **(g)**.

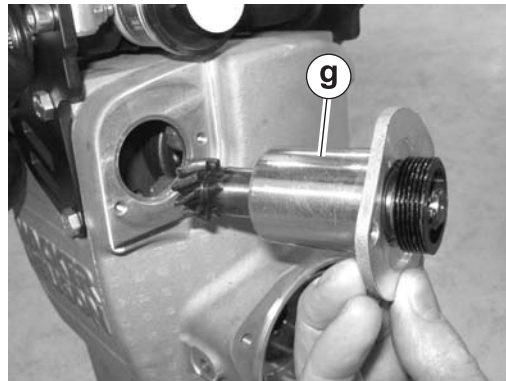

wc\_gr007554

### Result

The removal procedure is now complete.

### Installation

Perform the procedure below to install the oil pump.

- 7.5.1 Slide the cartridge assembly **(g)** into the crankcase.

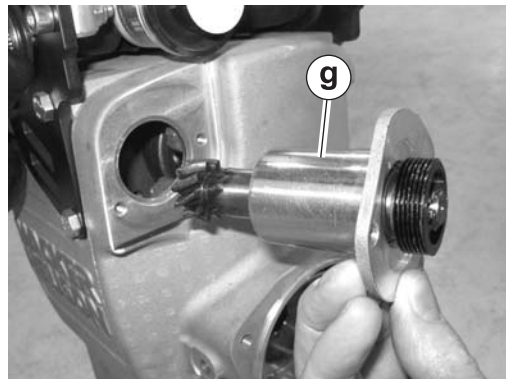

wc\_gr007554

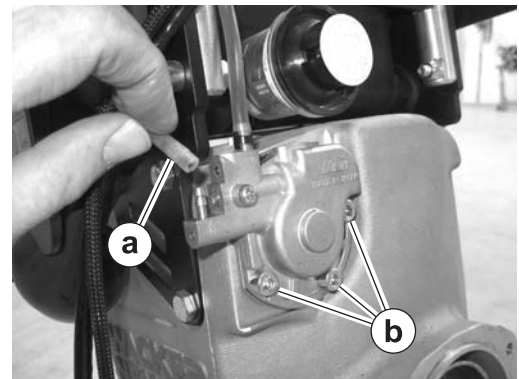

wc\_gr007550

- 7.5.2 Install the pump to the machine using three screws **(b)**. Torque the screws to 17 Nm (12 ft.lbs.).
- 7.5.3 Reconnect the output hose **(a)**.
- 7.5.4 Reinstall the engine.
- 7.5.5 Reinstall the carburetor.

### Result

The replacement procedure is now complete.

## 8 Low Oil Shutdown (if equipped)

### 8.1 Testing the Low Oil Unit

See Graphic: *wc\_gr003673*

The function of the low oil unit is to prevent the engine from running after startup if the engine is low on oil.

To test the low oil unit:

- 8.1.1 Remove the lower engine guard **(a)**.
- 8.1.2 Lay the machine down and remove the low oil unit **(b)** from the crankcase.
- 8.1.3 Disconnect the wiring from the engine to the low oil unit.
- 8.1.4 Attach a 9V battery to the low oil unit as shown. A functioning low oil unit should flash at a steady rate.
  - If the low oil unit does not flash at a steady rate, it has failed; replace it.
  - If the low oil unit does flash at a steady rate, continue.
- 8.1.5 Grasp the sensors **(c)** with your fingertips. This action will change the capacitance of the sensors, and will change the flashing action (duty cycle) of the low oil unit from a period where the light remains on longer than it is off, to one where the light is off longer than it is on.
  - If the low oil unit performs accordingly, it is functioning properly.
  - If the low oil unit does not perform accordingly, it has failed; replace it.

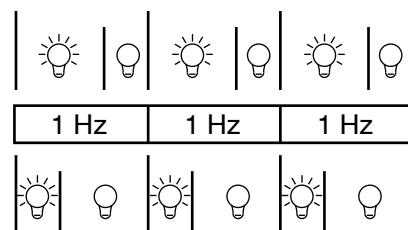
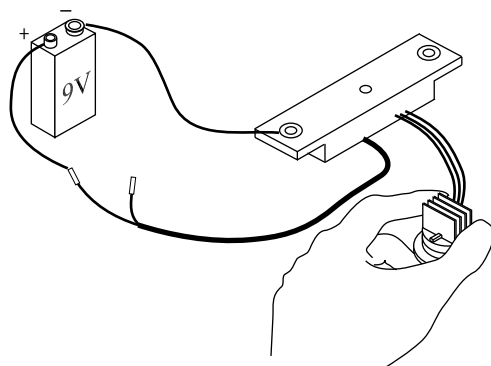
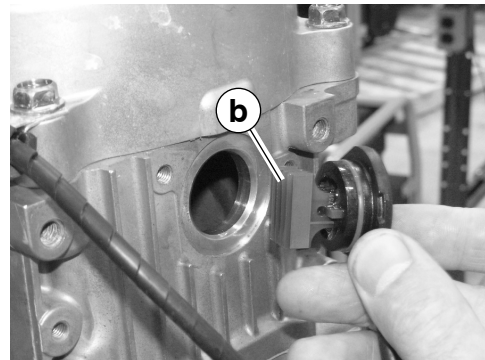
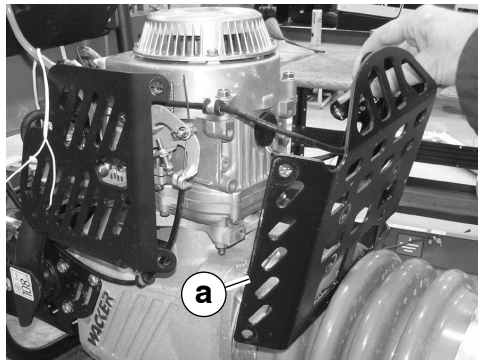

wc\_gr003673

**9 Troubleshooting**

**9.1 Engine Hard to Start**

<b>Problem / Symptom</b>	<b>Reason / Remedy</b>
The air filters are dirty.	Clean or replace the filters.
There is too much oil in the fuel <sup>(1)</sup> .	Drain the fuel from the tank and fill it with new mixed fuel.
The spark plugs are fouled <sup>(1)</sup> .	Clean or replace the spark plug. Measure the electrode gap.
Incorrect spark plug <sup>(1)</sup> .	Must use resistor-type spark plug to operate correctly.
The muffler or exhaust port is dirty.	Remove and clean the muffler. Clean the exhaust port.
The crankshaft seals are leaking.	Check/replace the seals (see the WM 80 Engine Repair Manual).
The fuel mixture adjustment is incorrect <sup>(1)</sup> .	Set the adjusting screw and clean the fuel jets.
The engine compression is low.	Replace the piston rings (see the WM 80, WM 90 or Yanmar Engine Repair Manual).

<sup>(1)</sup>Does not apply to the DS 720 or DS 70 Rammer.

**9.2 Engine Does Not Start**

Problem / Symptom	Reason / Remedy
There is no fuel in the tank.	Add fuel.
The fuel valve is closed.	Open the fuel valve.
The spark plug is fouled <sup>(1)</sup> .	Clean or replace the spark plug. Set the electrode gap.
The fuel filter is plugged.	Replace the fuel filter. Inspect the fuel lines.
The fuel mixture adjustment is incorrect <sup>(1)</sup> .	Set the adjusting screw and clean the fuel jets.
The ignition module has failed.	Replace the ignition module.
On machines with oil injection, the float switch has failed.	Replace the float switch.

<sup>(1)</sup>Does not apply to the DS 720 or DS 70 Rammer.

**9.3 Engine Does Not Accelerate or Runs Poorly**

Problem / Symptom	Reason / Remedy
The air filters are dirty.	Clean or replace the filters.
There is too much oil in the fuel <sup>(1)</sup> .	Drain the fuel from the tank. Fill with new mixed fuel.
The spark plug is fouled <sup>(1)</sup> .	Clean or replace the spark plug. Set the electrode gap.
Incorrect spark plug <sup>(1)</sup> .	Must use resistor-type spark plug to operate correctly.
The muffler or the exhaust port is dirty.	Remove and clean the muffler. Clean the exhaust port.
The crankshaft seals are leaking.	Check/replace the seals (see the WM 80, WM 90, or Yanmar Engine Repair Manual).
The fuel mixture adjustment is incorrect <sup>(1)</sup> .	Set the adjusting screw and clean the fuel jets.
There is an air leak in the carburetor system <sup>(1)</sup> .	Check all the connections.

<sup>(1)</sup>Does not apply to the DS 720 or DS 70 Rammer.

**9.4 Engine Overheats**

<b>Problem / Symptom</b>	<b>Reason / Remedy</b>
There is not enough oil in the fuel mix <sup>(1)</sup> .	Drain the fuel from the tank and fill it with new mixed fuel.
The carburetor fuel mix is set too lean <sup>(1)</sup> .	Reset the carburetor adjustments.
The cooling fins/fan blades are packed with dirt.	Clean the debris from the fins and the blades.

<sup>(1)</sup>Does not apply to the DS 720 or DS 70 Rammer.

**9.5 Rammer Does Not Tamp**

<b>Problem / Symptom</b>	<b>Reason / Remedy</b>
The muffler or the exhaust port is plugged.	Remove and clean the muffler. Clean the exhaust port.
The clutch is damaged.	Remove and replace the clutch.
The connecting rod in the ramming system is broken.	Disassemble the crankcase. Inspect and replace any damaged components.
The crankgear is broken.	Disassemble the crankcase. Inspect and replace any damaged components.
The pinion on the clutch drum shaft is broken.	Disassemble the crankcase. Inspect and replace any damaged components.
The engine compression is low.	Replace the piston rings (see the WM 80, WM 90, or Yanmar Engine Repair Manual).

9.6 Rammer Jumps Erratically

Problem / Symptom	Reason / Remedy
There is oil or grease on the clutch.	Inspect and clean the clutch.
The spring(s) in the ramming system are broken or worn.	Disassemble the spring cylinder. Inspect and replace any damaged components.
There are damaged parts in the spring cylinder assembly.	Disassemble the spring cylinder. Inspect and replace any damaged components.
There are damaged parts in the crankcase assembly.	Disassemble the crankcase. Inspect and replace any damaged components.
There is soil buildup on the ramming shoe.	Clean and inspect the shoe.
The engine speed is too low.	Adjust the engine speed.

**10 Technical Data**

**10.1 BS 50-2**

Item Number:		<b>BS 50-2</b> 0009380, 0009382, 0009384, 0009410 0009411, 0009413, 0620025, 0620048 0620609, 0620610, 0620733
<b>Rammer</b>		
Engine Model	type	WM80
Engine Speed - full	rpm	4400 ± 100
Engine Speed - idle	rpm	1800 ± 100
Clutch Engagement	rpm	2500 ± 100
Spark Plug	type	Champion RL95YC
Electrode Gap	mm (in)	0.5 (.020)
Cylinder Head Compression (cold)	bar/cm <sup>3</sup> (psi)	8.0–9.7 (120–140)
Air Cleaner	type	Three stage with cyclonic precleaner
Engine Lubrication	oil grade	With standard two-cycle oil use 50:1 ratio. With Wacker Neuson two-cycle or other oil meeting the NMMA TC-W3 specification, a ratio from 50:1 to 100:1 can be used.
Fuel Tank Capacity	l (qts.)	3.0 (3.2)
Fuel Consumption	l(qt.)/hr	1.0 (1.1)
Running Time	hour	2.9
Ramming System Lubrication	oil grade	SAE 10W30
Ramming System Capacity	ml (oz.)	562 (19)



## 10.2 BS 50-4

Item Number:	<b>BS 50-4s</b> 0620071, 0620078 0620811	
<b>Rammer</b>		
Engine Model	type	WM90
Engine Speed - operating	rpm	4200 ± 100
Engine Speed - idle	rpm	2000 ± 100
Clutch Engagement	rpm	2500 ± 100
Max. rated power @ rated speed	kW(HP)	2.1 (2.8) @ 4200 rpm
Spark Plug	type	NGK BM4A or BMR4A
Electrode Gap	mm (in)	0.6–0.7 (0.023–0.028)
Cylinder Head Compression (cold)	bar/cm <sup>3</sup> (psi)	8.0–9.7 (120–140)
Air Cleaner	type	Three stage with cyclonic precleaner
Engine Lubrication	oil grade	SAE 10W30 SE, SF or higher
Engine Oil Capacity	ml (oz.)	300 (10)
Fuel Tank Capacity	l (qts.)	3.0 (3.2)
Fuel	type	Regular unleaded gasoline
Fuel Consumption	l(qt.)/hr	1.2 (1.3)
Running Time	hour	2.5
Ramming System Lubrication	oil grade	SAE 10W30
Ramming System Capacity	ml (oz.)	562 (19)

**10.3 BS 500**

Item Number:		<b>BS 500</b> 0007550, 0008048 0008049, 0009074, 0009075
<b>Rammer</b>		
Engine Model	type	WM80
Engine Speed - full	rpm	4400 ± 100
Engine Speed - idle	rpm	1800 ± 100
Clutch Engagement	rpm	2800 ± 100
Spark Plug	type	Champion RL95YC
Electrode Gap	mm	0.5
Cylinder Head Compression (cold)	bar/cm <sup>3</sup>	8.0–9.7
Air Cleaner	type	Dual Element
Engine Lubrication	oil grade	With standard two-cycle oil - use 50:1 ratio. With Wacker Neuson two-cycle or two-cycle oil per NMMA TC-W3, API TC, JASO FC or ISO EGD specifications - use 100:1 or 50:1 ratio.
Ramming System Lubrication	oil grade	SAE 10W30
Ramming System Capacity	ml	562

10.4 BS 500S

Item Number:		<b>BS 500S</b> 0009211
<b>Rammer</b>		
Engine Model	type	WM80
Engine Speed - full	rpm	4700 ± 100
Engine Speed - idle	rpm	1800 ± 100
Clutch Engagement	rpm	2800 ± 100
Spark Plug	type	Champion RL95YC
Electrode Gap	mm (in.)	0.5 (.020)
Cylinder Head Compression (cold)	bar/cm <sup>3</sup> (psi)	8.0–9.7 (120–140)
Engine Lubrication	oil grade	With standard two-cycle oil - use 50:1 ratio. With Wacker Neuson two-cycle or two-cycle oil per NMMA TC-W3, API TC, JASO FC or ISO EGD specifications - 100:1 or 50:1 ratio.
Ramming System Lubri- cation	oil grade	SAE 10W30
Ramming System Capacity	ml (oz.)	562 (19)

**10.5 BS 50-2i**

Item Number:		<b>BS 50-2i</b> 0009332, 0009338 0009414, 0009416 0009473, 0620026, 0620611	<b>BS 50-2i</b> 0009383 0009412
<b>Rammer</b>			
Engine Model	type	WM80	
Engine Speed - full	rpm	4400 ± 100	4600 ± 100
Engine Speed - idle	rpm	1800 ± 100	
Clutch Engagement	rpm	2500 ± 100	
Spark Plug	type	Champion RL95YC	
Electrode Gap	mm (in)	0.5 (0.020)	
Cylinder Head Compression (cold)	bar/cm <sup>3</sup> (psi)	8.0–9.7 (120–140)	
Air Cleaner	type	Three stage with cyclonic precleaner	
Engine Lubrication	oil grade	With standard two-cycle oil use 50:1 ratio. With Wacker Neuson two-cycle or other oil meeting the NMMA TC-W3 specification, a ratio from 50:1 to 100:1 can be used.	
Fuel Tank Capacity	l (qts.)	3.0 (3.2)	
Fuel	type	Regular unleaded gasoline	
Fuel Consumption	l(qt.)/hr	1.0 (1.1)	
Running Time	hour	2.9	
Oil Tank Capacity	l (qts.)	0.70 (0.75)	
Ramming System Lubrication	oil grade	SAE 10W30	
Ramming System Capacity	ml (oz.)	562 (19)	

10.6 BS 500-oi

Item Number:		<b>BS 500-oi</b> 0009165, 0009343
<b>Rammer</b>		
Engine Model	type	WM80
Engine Speed - full	rpm	4400 ± 100
Engine Speed - idle	rpm	1800 ± 100
Clutch Engagement	rpm	2800 ± 100
Spark Plug	type	Champion RL95YC
Electrode Gap	mm (in.)	0.5 (0.020)
Cylinder Head Compression (cold)	bar/cm <sup>3</sup> (psi)	8.0–9.7 (120–140)
Engine Lubrication	oil grade	Wacker two-cycle or two-cycle oil per NMMA TC-W3, API TC, JASO FC or ISO EGD specifications.
Ramming System Lubrication	oil grade	SAE 10W30
Ramming System Capacity	ml (oz.)	562 (19)

**10.7 BS 60/70-2**

Item Number:	<b>BS 60-2</b> 0009388 0009417 0009421 0620612	<b>BS 60-2</b> 0009391 0009418	<b>BS 70-2</b> 0009397 0009399 0009424 0009425 0009427
<b>Rammer</b>			
Engine Model	type	WM80	
Engine Speed - full	rpm	4400 ± 100	4600 ± 100
Engine Speed - idle	rpm	1800 ± 100	
Clutch Engagement	rpm	2500 ± 100	
Spark Plug	type	Champion RL95YC	
Electrode Gap	mm (in)	0.5 (0.020)	
Cylinder Head Compression (cold)	bar/cm <sup>3</sup> (psi)	8.0–9.7 (120–140)	
Air Cleaner	type	Three stage with cyclonic precleaner	
Engine Lubrication	oil grade	With standard two-cycle oil use 50:1 ratio. With Wacker Neuson two-cycle or other oil meeting the NMMA TC-W3 specification, a ratio from 50:1 to 100:1 can be used.	
Fuel Tank Capacity	l (qts.)	3.0 (3.2)	
Fuel Consumption	l(qt.)/hr	1.2 (1.3)	1.3 (1.4)
Running Time	hour	2.5	2.3
Ramming System Lubrication	oil grade	SAE 10W30	
Ramming System Capacity	ml (oz.)	890 (30)	

## 10.8 BS 60-4

Item Number:		<b>BS 60-4s</b> 0620072 0620074 0620483 0620563  0620073 Rev 201 and lower	<b>BS 60-4s</b> 0620073 Rev 202 and higher
<b>Rammer</b>			
Engine Model	type	WM90	WM100
Engine Speed - operating	rpm	4200 ± 100	
Engine Speed - idle	rpm	2000 ± 100	
Clutch Engagement	rpm	2500 ± 100	
Max. rated power @ rated speed (4200 rpm)	kW(HP)	2.1 (2.8)	2.4 (3.2)
Spark Plug	type	NGK BM4A or BMR4A	
Electrode Gap	mm (in)	0.6–0.7	
Cylinder Head Compression (cold)	bar/cm <sup>3</sup> (psi)	8.0–9.7	
Air Cleaner	type	Three stage with cyclonic precleaner	
Engine Lubrication	oil grade	SAE 10W30: SE, SF or higher	
Engine Oil Capacity	ml (oz.)	300	
Fuel Tank Capacity	l (qts.)	3.0	
Fuel	type	Regular unleaded gasoline	
Fuel Consumption	l(qt.)/hr	1.2	
Running Time	hour	2.5	
Ramming System Lubrication	oil grade	SAE 10W30	
Ramming System Capacity	ml (oz.)	890	

**10.9 BS 600/700**

Item Number:		<b>BS 600</b> 0007551, 0008207 0009076, 0009307	<b>BS 700</b> 0007552, 0008051 0008052, 0009308
<b>Rammer</b>			
Engine Model	type	WM80	
Engine Speed - full	rpm	4350 ± 100	
Engine Speed - idle	rpm	1800 ± 100	
Clutch Engagement	rpm	2800 ± 100	
Spark Plug	type	Champion RL95YC	
Electrode Gap	mm (in.)	0.5 (0.020)	
Cylinder Head Compression (cold)	bar/cm <sup>3</sup> (psi)	8.0–9.7 (120–140)	
Air Cleaner	type	Dual Element	
Engine Lubrication	oil grade	With standard two-cycle oil - use 50:1 ratio. With Wacker Neuson two-cycle or two-cycle oil per NMMA TC-W3, API TC, JASO FC or ISO EGD specifications - 100:1 or 50:1 ratio.	
Ramming System Lubrication	oil grade	SAE 10W30	
Ramming System Capacity	ml (oz.)	890 (30)	



## 10.10 BS 600S

Item Number:		<b>BS 600S</b> 0009212
<b>Rammer</b>		
Engine Model	type	WM80
Engine Speed - full	rpm	4600 ± 100
Engine Speed - idle	rpm	1800 ± 100
Clutch Engagement	rpm	2800 ± 100
Spark Plug	type	Champion RL95YC
Electrode Gap	mm (in.)	0.5 (0.020)
Cylinder Head Compression (cold)	bar/cm <sup>3</sup> (psi)	8.0–9.7 (120–140)
Engine Lubrication	oil grade	With standard two-cycle oil - use 50:1 ratio. With Wacker Neuson two-cycle or two-cycle oil per NMMA TC-W3, API TC, JASO FC or ISO EGD specifications - 100:1 or 50:1 ratio.
Ramming System Lubrication	oil grade	SAE 10W30
Ramming System Capacity	ml (oz.)	890 (30)

**10.11 BS 60/70-2i**

Item Number:	<b>BS 60-2i</b> 0009339 0009419 0620613 0620614	<b>BS 60-2i</b> 0009393 0009420	<b>BS 70-2i</b> 0009341 0009401 0009426 0009428
<b>Rammer</b>			
Engine Model	type	WM80	
Engine Speed - full	rpm	4400 ± 100	4600 ± 100
Engine Speed - idle	rpm	1800 ± 100	
Clutch Engagement	rpm	2500 ± 100	
Spark Plug	type	Champion RL95YC	
Electrode Gap	mm (in)	0.5 (0.020)	
Cylinder Head Compression (cold)	bar/cm <sup>3</sup> (psi)	8.0–9.7 (120–140)	
Air Cleaner	type	Three stage with cyclonic precleaner	
Engine Lubrication	oil grade	With standard two-cycle oil use 50:1 ratio. With Wacker Neuson two-cycle or other oil meeting the NMMA TC-W3 specification, a ratio from 50:1 to 100:1 can be used.	
Fuel Tank Capacity	l (qts.)	3.0 (3.2)	
Fuel	type	Regular unleaded gasoline	
Fuel Consumption	l(qt.)/hr	1.2 (1.3)	1.4 (1.3)
Running Time	hour	2.5	2.3
Oil Tank Capacity	l (qts.)	0.70 (0.75)	
Ramming System Lubrication	oil grade	SAE 10W30	
Ramming System Capacity	ml (oz.)	890 (30)	

10.12 BS 600/700-oi

Item Number:		<b>BS 600-oi</b> 0009166, 0009262	<b>BS 700-oi</b> 0009167, 0009328
<b>Rammer</b>			
Engine Model	type	WM80	
Engine Speed - full	rpm	4350 ± 100	
Engine Speed - idle	rpm	1800 ± 100	
Clutch Engagement	rpm	2800 ± 100	
Spark Plug	type	Champion RL95YC	
Electrode Gap	mm (in.)	0.5 (0.020)	
Cylinder Head Compression (cold)	bar/cm <sup>3</sup> (psi)	8.0–9.7 (120–140)	
Engine Lubrication	oil grade	Wacker Neuson two-cycle or two-cycle oil per NMMA TC-W3, API TC, JASO FC or ISO EGD specifications.	
Ramming System Lubrication	oil grade	SAE 10W30	
Ramming System Capacity	ml (oz.)	890 (30)	

**10.13 BS 600/700 High Altitude**

Item Number:		<b>BS 600</b> 0009077	<b>BS 700</b> 0009079
<b>Rammer</b>			
Engine Model	type	WM80	
Engine Speed - full	rpm	4350 ± 100	
Engine Speed - idle	rpm	1800 ± 100	
Clutch Engagement	rpm	2800 ± 100	
Spark Plug	type	Champion RL95YC	
Electrode Gap	mm (in.)	0.5 (0.020)	
Cylinder Head Compression (cold)	bar/cm <sup>3</sup> (psi)	8.0–9.7 (120–140)	
Air Cleaner	type	Dual Element	
Engine Lubrication	oil grade	With standard two-cycle oil - use 50:1 ratio. With Wacker Neuson two-cycle or two-cycle oil per NMMA TC-W3, API TC, JASO FC or ISO EGD specifications - 100:1 or 50:1 ratio.	
Ramming System Lubrication	oil grade	SAE 10W30	
Ramming System Capacity	ml (oz.)	890 (30)	

10.14 BS 65-V

Item Number:		<b>BS 65-V</b> 0009396, 0009423
<b>Rammer</b>		
Engine Model	type	WM80
Engine Speed - full	rpm	4400 ± 100
Engine Speed - idle	rpm	1800 ± 100
Clutch Engagement	rpm	2500 ± 100
Spark Plug	type	Champion RL95YC
Electrode Gap	mm (in.)	0.5 (0.020)
Cylinder Head Compression (cold)	bar/cm <sup>3</sup> (psi)	8.0–9.7 (120–140)
Air Cleaner	type	Three stage with cyclonic precleaner
Engine Lubrication	oil grade	With standard two-cycle oil use 50:1 ratio. With Wacker Neuson two-cycle or other oil meeting the NMMA TC-W3 specification, a ratio from 50:1 to 100:1 can be used.
Fuel Tank Capacity	l (qts.)	3.0 (3.2)
Fuel Consumption	l(qt.)/hr	1.2 (1.3)
Running Time	hour	2.5
Ramming System Lubrication	oil grade	SAE 10W30
Ramming System Capacity	ml (oz.)	890 (30)

**10.15 BS 650**

Item Number:		<b>BS 650</b> 0008209
<b>Rammer</b>		
Engine Model	type	WM80
Engine Speed - full	rpm	4350 ± 100
Engine Speed - idle	rpm	1800 ± 100
Clutch Engagement	rpm	2800 ± 100
Spark Plug	type	Champion RL95YC
Electrode Gap	mm	0.5
Cylinder Head Compression (cold)	bar/cm <sup>3</sup>	8.0–9.7
Air Cleaner	type	Dual Element
Engine Lubrication	oil grade	With standard two-cycle oil - use 50:1 ratio. With Wacker Neuson two-cycle or two-cycle oil per NMMA TC-W3, API TC, JASO FC or ISO EGD specifications - 100:1 or 50:1 ratio.
Ramming System Lubrication	oil grade	SAE 10W30
Ramming System Capacity	ml	890

Notes

**10.16 DS 70**

Item Number:	<b>DS 70</b> 0009342 0009402 0009403	<b>DS 70</b> 0620049 0620050	<b>DS 70</b> 0620052 0620053 0620054
<b>Rammer</b>			
Operating weight	kg (lbs.)	83 (183)	
Percussion rate <sup>(2)</sup>	strokes/min.	670	
Single stroke work	J/mkp	100	
Stroke of ramming shoe (up)	mm (in.)	to 71 (2.78)	
Ramming system lubrication	oil grade	SAE 10W30	
Ramming system oil capacity	ml (oz.)	890 (30)	

<sup>(2)</sup> Percussion rate can be adjusted with the throttle lever.



Item Number:	<b>DS 70</b> 0009342 0009402 0009403	<b>DS 70</b> 0620049 0620050	<b>DS 70</b> 0620052 0620053 0620054
Engine			
Engine Type	single cylinder, air cooled, 4-stroke diesel engine		
Engine Make	Yanmar		
Engine Model	L48EE-DWK3	L48V4LF9T-9EWSA	L48EE-DWK3
Max. rated power @ rated speed	kW (Hp)	3.1 (4.1) @ 3450 rpm	
Displacement	cm <sup>3</sup> (in <sup>3</sup> )	211 (12.8)	
Engine Speed - operating	rpm	3450	
Engine Speed - idle	rpm	1050 ± 150	
Engine Speed - clutch engagement	rpm	2500 ± 200	
Valve Clearance (cold)	mm (in.)	0.15 (0.006)	
Air Cleaner	type	Dual Element	
Engine Lubrication	oil grade	CC or better <sup>(1)</sup>	
Engine Oil Capacity	ml (oz.)	800 (27)	
Fuel	type	No. 2 Diesel, cetane > 45	
Fuel Tank Capacity	l (gals.)	4.2 (1.1)	
Fuel consumption	l/h (gal./hr.)	0.9 (0.25)	
Running Time	hour	4.6	

<sup>(1)</sup> Refer to Lubrication.

**10.17 DS 720**

Item Number:		<b>DS 720</b> 0008200 Rev. 115 and lower 0008203 Rev. 114 and lower	<b>DS 720</b> 0008200 Rev. 116 and higher 0008203 Rev. 115 and higher	<b>DS 720</b> 0009309
<b>Rammer</b>				
Operating weight	kg (lbs.)	75 (165)		
Percussion rate <sup>(2)</sup>	strokes/ min.	650-700		
Single stroke work	J/mkp	100		
Stroke of ramming shoe (up)	mm (in.)	to 75 (3)		
Ramming system lubrication	oil grade	SAE 10W30		
Ramming system oil capacity	ml (oz.)	890 (30)		

<sup>(2)</sup> Percussion rate can be adjusted with the throttle lever.

Item Number:	<b>DS 720</b> 0008200 Rev. 115 and lower 0008203 Rev. 114 and lower	<b>DS 720</b> 0008200 Rev. 116 and higher 0008203 Rev. 115 and higher	<b>DS 720</b> 0009309
<b>Engine</b>			
Engine Type	single cylinder, air cooled, 4-stroke diesel engine		
Engine Make	Yanmar		
Engine Model	L40AE-DWK2	L48EE-DWK3	
Rated Power	kW (Hp)	3.1 (4.2)	3.5 (4.7)
Displacement	cm <sup>3</sup> (in <sup>3</sup> )	199 (12.1)	211 (12.8)
Engine Speed - full load	rpm	3600	
Engine Speed - idle	rpm	1200 ± 200	
Engine Speed - clutch engagement	rpm	2000 ± 200	
Valve Clearance (cold)	mm (in.)	0.15 (0.006)	
Air Cleaner	type	Dual Element	
Engine Lubrication	oil grade	CC or better <sup>(1)</sup>	
Engine Oil Capacity	ml (oz.)	800 (27)	
Fuel	type	No. 2 Diesel, cetane > 45	
Fuel Tank Capacity	l (gals.)	5.7 (1.5)	
Fuel consumption	l/h (gal./hr.)	0.9 (0.25)	

<sup>(1)</sup> Refer to *Lubrication*.

