

PAVIJET

MINI PAVERS



Simple to use
Low maintenance
Labor & equipment cost saving
...one smart investment.

www.gradecontrol.com.au 02 43851041

CONTACT US FOR DEMONSTRATION AND HIRE DETAILS

PAVIJET MG7 (forward driving)

MINI PAVERS

The new compact Pavijet Mini Paver is the most recent evolution in the asphalt finishing sector.

With an international patent, the Pavijet is the only paver able to fill with:

- Gravel
- Sand
- Stones
- Asphalt (hot and cold)
- Concrete

The Pavijet can do many jobs, such as:

- Patching roads
- Cycle tracks
- Footpaths
- Pavements
- Parking lots
- Driveways
- Garden and park paths
- Utility trenches
- Sand in courtyards for self-locking bricks
- Flat layers of concrete in worksites

The Pavijet can also bypass any obstacle in the way, like advertising signs, trees, etc. thanks to the retractable screed.

Easy to use and to transport:

- The Pavijet MG7 is a completely hydraulic paver. It can be connected to any kind of skid loader with a minimum of 20 HP (15 kw).
- The attachment is mechanical and the hydraulic connection is done with quick connects.
- The Pavijet can be loaded and unloaded from the truck by the same skid loader.
- Thanks to its small dimensions, the Pavijet is easy to use and to transport.



MG7 paving a shoulder.

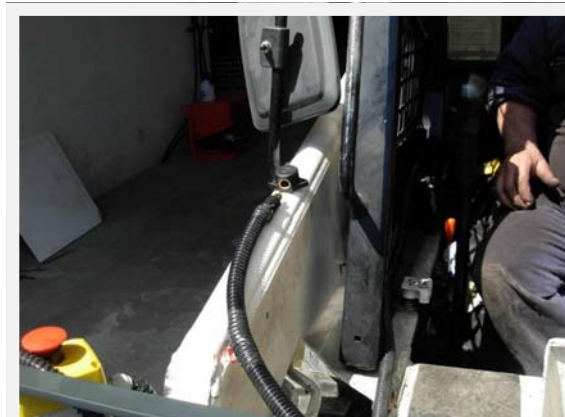

Power connection to skidloader (MG6 & MG7).



Loading hopper from truck



Laying base



Laying sidewalk around gutter

Feeding:

- The Pavijet MG7 can lay hot and cold asphalt, as well as cement, sand and crushed stones. It is possible to use the same machine to spread fill and later to pave. *No other finisher is able to do this.* This machinery is ideal for laying down the sand base before brick paving in patios.
- The central auger brings the material to the screed.
- The auger's speed depends on the speed of the loader's motor.

Functions:

- All the functions are hydraulic (auger, screed lifting and lowering, telescopic screed, hopper's opening and closing).
- Because of the retractable hydraulic screed, the machine is very versatile and is able to avoid obstacles that may be in the way.
- The Pavijet MG7 can be controlled from the skid loader and/or with a wireless remote control.
- The wireless remote control allows the operator to have a complete view of the work in front of the machine.

Advantages:

- Variable paving width from 7.87" to 74.80" (0.2m to 1.9m)
- Compact dimensions
- Low price
- High paving speed, up to 82' per minute
- Avoids obstacles along the way
- Possibility to be load the hopper from the street
- Can pave many different kinds of materials
- Wireless remote controlled
- Machine is completely hydraulic



MG7 screed extended to its full width. Screed can also be heated for use with hot bitumen.



Hand Held Remote Control



MG6 & MG7 Control Panel



MG6 & MG7 Control Panel



The Pavijet has its own battery, but for jobs that are going to take more than a couple of hours, the unit needs to be connected to the power of the loader.



MG7 Self-Leveling System



MG6 & MG7 Hydraulic Quick Coupler



MG6 & MG7 Quick Attach



MG7 Dampers / Limiters



MG7 Hopper Auger



MG7 closed and ready for transport.



MG7 closed and ready for transport.



MG7 opened up and ready to work.

MG7 Layout:

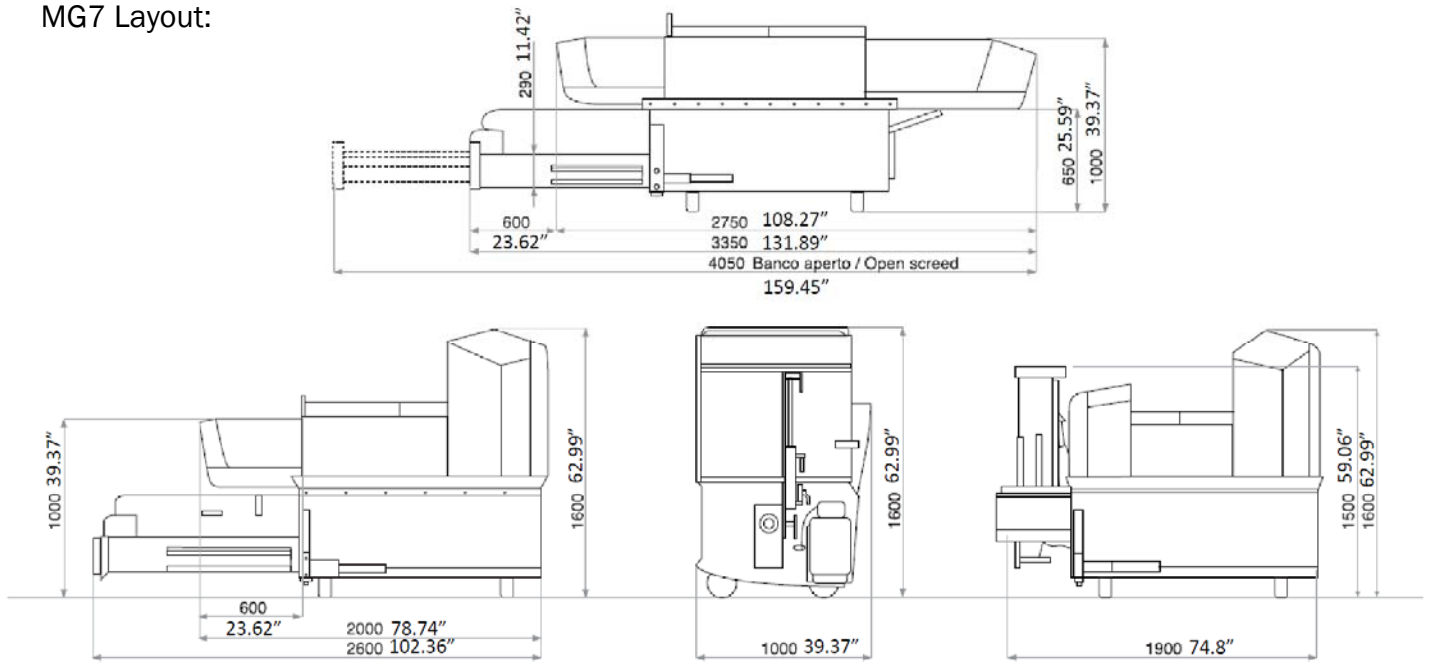

MG7 Specifications:

Paving width:	7.87" to 74.80" (.2m to 1.9m)
Paving height:	from -1.97" to 9.84" (-5cm to 25cm)
Hopper capacity:	49.44 cubic feet (1.4 cubic meters)
Oil flow:	15.85 gal/min (60 l/min)
Paving speed:	up to 82.02'/min (25m/min)
Hydraulic pressure:	2,611 psi (180 bar)
Weight:	1,567 lbs. (711 kg)
Vibration (optional):	60 Hz
Paving direction:	forward
Paving material:	cold or hot (heated by LPG)
Hot paving temperature:	140 degrees
Feeding:	front and lateral
Commands:	from the loader or by radio control
Functions:	all hydraulic
Auger's diameter:	7.87" (200 mm)
Machinery washing:	with a manual pump
Paint:	anti-corrosive
Colors:	grey and yellow
Certification:	EC conformity

PAVIJET MG6 (reverse driving)

MINI PAVERS



The Pavijet MG6 Mini Paver is able to move backwards and is useful for sidewalks where there is no space to move forward. The concept is the same as the MG7, but the MG6 has two retractable screeds instead of one, with paving width from 15.75" to 90.55" (0.40m to 2.3m).

Features:

- Telescopic hydraulic screed paving
- Easy to attach on skid loaders or loaders
- Hydraulic hopper which can be loaded from a truck from either the front or side
- Hopper capacity 42.38 cubic feet or 1.57 cubic yards (1.2 cubic meters)
- Screed heating by propane gas
- Central hydraulic conveying
- International patented



MG6 closed & ready for transport.



MG6 fully open with screeds extended. The MG6 is a center lined paver.

MG6 Layout:

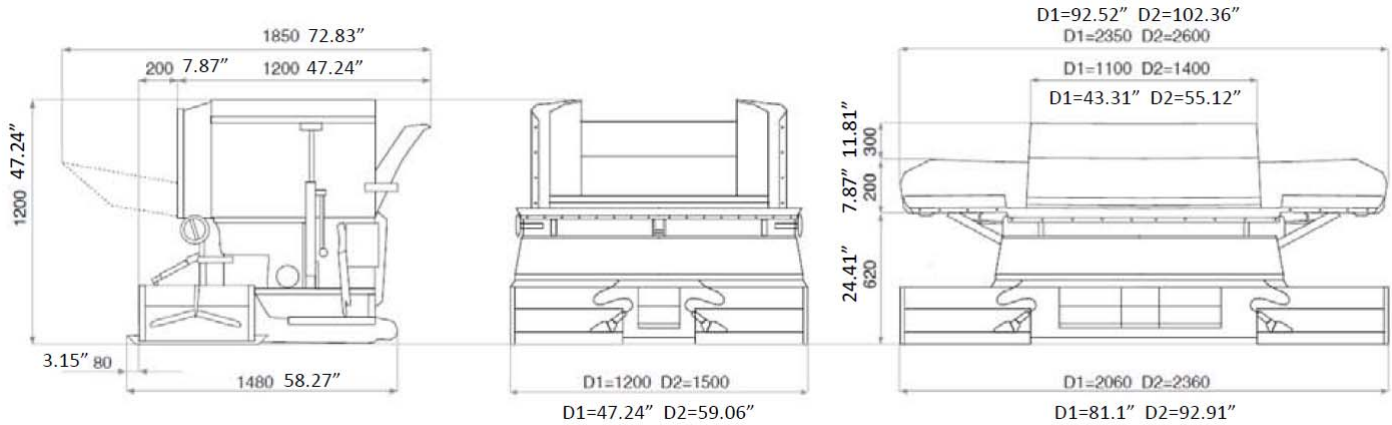

MG6 Specifications:

Paving width:	15.75" to 90.55" (.4m to 2.3m)
Paving height:	from -1.97" to 4.72" (-5cm to 12cm)
Hopper capacity:	42.38 cubic feet (1.2 cubic meters)
Oil flow:	15.85 gal/min (60 l/min)
Paving speed:	up to 82.02'/min (25m/min)
Hydraulic pressure:	2,611 psi (180 bar)
Weight:	981 lbs. (445 kg)
Vibration (optional):	60 Hz
Paving material:	cold or hot (heated by LPG)
Hot paving temperature:	140 degrees
Loading:	front and lateral
Commands:	hydraulic, from aboard the machinery
Bar, hoppers, auger moving:	hydraulic
Machinery washing:	with a manual pump
Paint:	anti-corrosive
Available colors:	grey or yellow
Certification:	EC conformity

CONTACT US FOR DEMONSTRATION AND HIRE DETAILS



02 43851041

3/4 Bonmace CI Berkeley Vale NSW 2261

www.gradecontrol.com.au