



Pumping
Spraying
Injecting
Plastering

B 100

The pump that will surprise you

B 100

Building Renovating Paving Reinforcing



Technical data

Hydraulic power-pack	
Diesel engine	18,5 kW
Electric motor	18,5 kW
Hydraulic output	60 l/min
Hydraulic pressure	140 bar
Compressor (on request)	400l/min
Dimensions	
Height	1020 mm
Length	1700 mm
Width	700 mm
Weight	420 kg
Weight with CHD engine	495 kg

Pump	
Maximum theoretical output *	250 l/min
Maximum theoretical pressure *	12 bar
Maximum granule size	25 mm
Pumping distance	
Horizontal **	45 m
Vertical **	15 m
Hopper capacity	180 l
Dimensions	
Height	805 mm
Length	2420 mm
Width	900 mm
Weight	420 kg

* With 2L8 stator and rotor
pressure: 25 bar
horizontal distance : 60 m
vertical distance : 30 m
max granule size : 16 mm
theoretical output : 170 l/min

** Depends on material,
consistency and hose diameter
Both distances cannot be
reached simultaneously
Consistency class: S4 (fluid)
Slump range: 16 to 20 cm

The BUNKER range
■ screw mixing pumps and pistons for plaster,
mortar, and fluid cement mixes
■ screw pumps for concrete
■ systems and machines for spritz-beton
■ mixers - conveyors for floor screed

Bunker retains the right to modify the data at anytime - ©2004 by TEK.SP.ED. - all rights reserved - printed in Italy - 2004/73-0306-GB

TEK.SP.ED. s.r.l.

via G. Falcone, 91
80025 Casandrino (NA)
tel. +39 081 5053621
fax +39 081 8332973
info@bunker-teksped.com
www.bunker-teksped.com



Full hydraulical drive concrete pump with output and pressure control

Useful



One pump with many uses

To pump concrete, traditional or special mortars, fibre-reinforced mortars, self-levelling floor screeds and cellular concrete. You can spray plaster and concrete. You can inject cement or special mixes, micro-piles or ties.

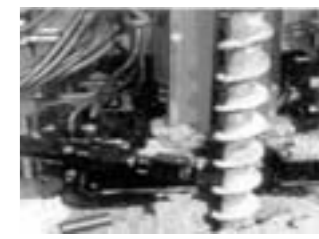

Concrete pumping

Sprayed concrete

Plaster

Injections

Its small size facilitates positioning under mixers

B100

You can't do without it

Innovative

Made by Bunker, the world's smallest concrete pump with rotor-stator system. All hydraulic drive with gradual output and pressure control

The unique alternative to much more expensive and difficult to manoeuvre machines.

With the B100, you can pump mortar and concrete with aggregates up to 25 mm, you can spray plaster and concrete, inject micro-piles and ties.

The B100's defining feature is the innovative separation of the power pack and pump.

Flexible hoses with quick couplings connect the power pack and the pump. The feature enables the pump to be powered remotely even from long distances.

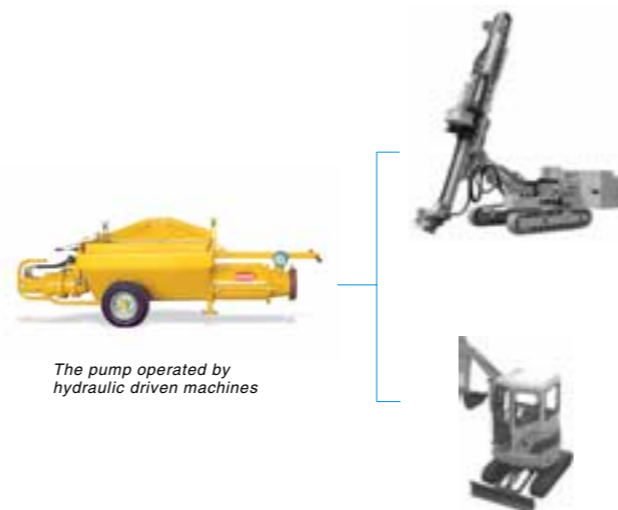

The pump operated by hydraulic driven machines

Versatile

This practical configuration makes the B100 both compact and light, facilitating transport and positioning in difficult to access building sites, town centers, slopes, etc.

Should you already possess an adequate source of hydraulic power such as an excavator with hydraulic power takeoff, then the pump may be driven from that source thus saving on the cost of the power pack. ... a great advantage !

The hydraulic power-pack is a true power unit. With its 18.5 kW and 60 litres oil output, it can safely operate not only the B100, but some hydraulic tools as well : drills, augers, and saws. ... Truly revolutionary!

B100 with mixer ideal for piling works.

The B100 with mixer is recommended where batched mixes are required as is the case with piling works where a batched mix of mortar or concrete is needed for each set of micro-piles.



Hydraulic tools operated by the power-pack

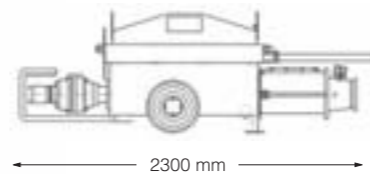
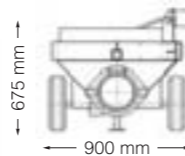
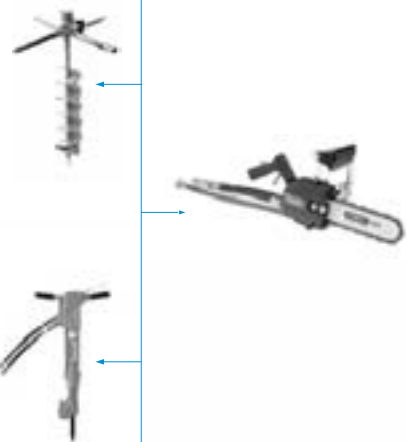



The hour-counter helps you to schedule work and maintenance.



Control LED's enable easy monitoring.



The Diesel engine speed is controlled by a handy lever.



Fuel tank capacity is sufficient for an entire work shift.

Conformity to safety regulations



Easy to manoeuvre guard locking devices prevent opening of the protective grids of the hopper and mixer. If opened, they stop the rotation of the screw feeder or mixer paddles.

How does it work ?

The B100 is a simply designed, volumetric pump without valves. The key components are an eccentric steel alloy rotor that has a single thread and a highly abrasion resistant rubber stator that has a double thread. As the rotor turns inside the stator, the meshing geometry of the two components creates sealed chambers on both inlet and outlet sides. Rotation of the rotor opens and closes the chambers alternatively and gradually. In this way, the material is continuously transported. Output is in proportion to rotation speed.

The Diesel engine.

The hydraulic power-pack is driven by a new Lombardini engine. It is powerful, ecologically friendly unit with low fuel consumption and very low noise. As a result, the B100 is able to operate close to hospitals, schools and residential districts.



Controls

The screw pump may be readily operated in either forward or reverse, thus enabling the hoses to empty in case of clogging.

Pumping output control.

Gradual output control ensures precision injecting and plastering avoiding waste of material.

Mixer speed control.

Paddle speed on the M180 mixer is adjustable to provide optimum mixing dynamics.

Pump remote control.

A handy low voltage remote control with a very long cable to start and stop the B100.

Compressor

The compressor is used for plastering and concrete spraying. There are two versions available : with mechanical or with hydraulic transmission.



Vibrating screen

The B100 is equipped with a vibrating screen powered by the 12V battery of the hydraulic power-pack. This powerful vibrator ensures quick and efficient screening, preventing aggregate with excessive granule size from reaching the hopper.

The compressor, the pump for set accelerator and the high pressure cleaner are directly powered by the B100's hydraulic circuit.

Pumping pressure

Pumping pressure can be accurately controlled by the pressure switch and can be verified on the pressure gauge located at the pump outlet.



compressor with hydraulic motor



dosing pump for set accelerator



high pressure cleaner





Dosing pump for set accelerator

For sprayed concrete works, the B100 can be equipped with either a tank or a pump for set accelerator. The pump provides a more accurate dosing.



Foam generator gun

With the B100, you can produce cellular concrete or light concrete. All you need is the foam generator, the HP cleaner and the compressor (also used for plaster and concrete spraying).



Hoses

Steel or rubber hoses of different diameters and lengths, accessories such as the hose holder, the discharge hopper allow you to use the machine for all applications. They will optimise the performances of your B100.



Cleaning the pump and accessories

At the end of each working day, the pump and accessories can be easily cleaned, thanks to a handy hydraulic high pressure cleaner driven by the hydraulic power-pack.



Hose cleaning

You can use the compressor for hoses cleaning. When the compressed air coupling is connected to the hose, the sponge ball inside the pipe is pushed by air and the residual material flows out.



Stator



Rubber nozzles for plasters



Nozzles for joint filling



Steel nozzles for plasters



Rotor



Injection gun with pressure gauge



Spray gun for joint filling



Plastering spray gun



Sponge balls for hose cleaning



Polyurethane spray gun for concrete



Steel spray gun for sprayed concrete



Pressure switch

A special painting process ensures longterm protection increasing the value of the used machine.

The strong large diameter wheels facilitate the pump's positioning on the construction site.

Loading ramp Fast 600

... it's child's play



To make the B100 even easier to manoeuvre, Bunker invented Fast 600, loading and unloading ramps for the pump and power pack.



Replacing the stator is easy



An innovative tool is a feature item stands out among the B100's accessories: it facilitates replacing a worn stator simply and safely.



Accessories include a tool box containing essential spare parts.



A large, practical drain plug facilitates washing the hopper.



The concrete pump is designed for exceptional wear and abrasion resistance.